



2013–2014 CO₂ laser consumables



Our value proposition

- Product breadth – with over 2,800 part numbers
- OEM quality/consistency for nozzles, ceramics and optics
- Technical/application support from OEM-trained technicians
- 100% satisfaction guarantee



Page	OEM
88–90, 92–94, 96, 97, 99–103, 105	Adige
1	Amada
16	Amada – optics
19	Behrens
20	Bystronic
31	Bystronic – optics
33	Cincinnati
34	Cincinnati – optics
88–90, 94, 105	Durma
88–90, 94, 105	Ermaksan
88–90, 92–94, 96, 97, 101–103, 105	Finn Power
88–90, 92–94, 96, 97, 105	GHT
36	Haas
37	Haco
38	Hankwang
88, 94, 105	Hans
93	Koike
41	Laserdyne
42	Laser Lab
42	Laser Lab – optics
43	LVD
46	LVD – optics
47–73, 94, 99, 100, 105	Mazak
74	Mazak – optics
76	Mitsubishi
81	Mitsubishi – optics
83	Murata Wiedemann – Fanuc
84	Niigata
85	NTC – Beyeler
87	NTC – Beyeler – optics
88	Precitec
106	Precitec – optics
108	Prima Industrie
115	Prima Industrie – optics
116	Raskin
117	Rouchaud
118–121, 88–90, 94, 105	Salvagnini
122	Strippit
123	Tanaka
124	Tanaka – optics
125	Thyssen
126	Trumpf
142	Trumpf – optics
144	Valfivre

Hypertherm and Centricut are registered trademarks of Hypertherm Inc. and may be registered in the United States and/or other countries. All other trademarks are the properties of their respective owners. Centricut is in no way affiliated with Amada, Behrens, Bystronic, Cincinnati, Finn-Power, GHT-SHT, Haas, Haco, Hankwang, Laserdyne, Laser Lab, LVD, Mazak, Mitsubishi, Murata Wiedemann, Fanuc, Niigata, NTC, Beyeler, Precitec, Prima Industrie, Raskin, Rouchaud, Salvagnini, Strippit, Tanaka, Thyssen, Trumpf and Valfivre.

CO₂ laser nozzles

Nozzle options

All Centricut nozzles are engineered and manufactured to the highest standards. Select the OEM quality nozzle best suited for your application needs.

Good

Copper nozzles are the most commonly used nozzle and offer good durability and nozzle life.

Better

Chrome plated nozzles have a shiny, mirror-like finish and provide increased spatter resistance, improved durability and longer life than copper nozzles.

Look for CP in the part number to identify a chrome plated nozzle.

Best

Hard chrome plated nozzles are our premium nozzles offering the highest level of durability and longest nozzle life. These nozzles are not as shiny as chrome plated and have a dull appearance.

Look for HCP in the part number to identify a hard chrome nozzle.

Nozzle selection guide

Type of nozzle	Reasons for selecting
CP (chrome plated)	Nozzles plated with chrome for increased durability. These nozzles are easier to clean, resist damage due to 'tip-ups' and have better spatter resistance over non-plated nozzles. For use in all laser cutting applications.
Conical	Conical internal geometry for high pressure, non-ferrous cutting applications using nitrogen, air or argon.
Cylindrical	Cylindrical internal geometry for low pressure, mild steel cutting applications using oxygen.
Double	Insert pressed into a standard cylindrical nozzle for improved edge quality, laminar gas flow and spatter resistance. Primarily used in mild steel applications.
HCP (hard chrome plated)	Enhanced durability chrome plated nozzles. These nozzles are easier to clean, resist damage due to 'tip-ups' and have better spatter resistance over non-plated nozzles. For use in all laser cutting applications.
HP (high pressure) HD (high density)	Conical style nozzle for high pressure, non-ferrous cutting applications using nitrogen, air or argon.
Inner	Also referred to as a 'nozzle insert'. Works in conjunction with an outer nozzle to create a double nozzle. Primarily used in mild steel applications.
Low pressure	Cylindrical style nozzle for low pressure, mild steel cutting applications using oxygen.
Outer	Works in conjunction with an inner nozzle to create a double nozzle. Primarily used in mild steel applications.
Shower	Nozzles with a center orifice surrounded by smaller jets. The smaller jets focus the assist gas into the kerf, creating improved edge quality and the ability to cut thicker material. Primarily used in mild steel applications.



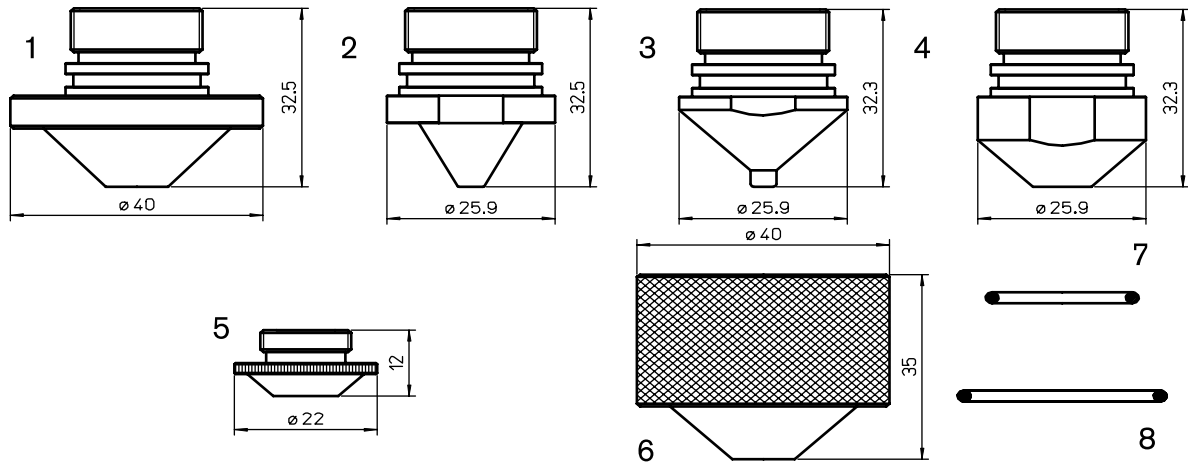

Consumables

	Centricut part number	Reference number	Alternate reference	Description	Pkg qty
1	AM425-1000	71101000	L896X	Nozzle - 1.5 mm CP clean cut	1
	AM425-2000	71102000	L897X	Nozzle - 1.75 mm CP clean cut	1
	AM425-1999	71101999	L898X	Nozzle - 2.0 mm CP clean cut	1
	AM425-0999	71101999	L899X	Nozzle - 2.5 mm CP clean cut	1
2	AM324-6892-1.3	6506892	L81X	Nozzle - 1.3 mm CP	1
	AM324-6815CP	6506892	L92X	Nozzle - 1.5 mm CP	1
	AM324-0092CP	6506892	L93X	Nozzle - 1.8 mm CP	1
	AM324-6892-2.0	74712001, 6506892	L39X	Nozzle - 2.0 mm CP	1
3	AM308-1913CP	71101901	L63X	Nozzle - 1.3 mm CP	1
	AM308-1902	71101902	L91X	Nozzle - 1.5 mm CP	1
	AM308-1918CP	71101901	L75X	Nozzle - 1.8 mm CP	1
	AM308-1901-2.0	71101901, 845735	L29X	Nozzle - 2.0 mm CP	1
	AM308-1925CP		L809X	Nozzle - 2.5 mm CP	1
	AM308-1930CP	71101901	L808X	Nozzle - 3.0 mm CP	1
	4	AM308-2013CP		L297X	Nozzle - 1.3 mm CP
AM308-2015CP		62094001, 71102001	L298X	Nozzle - 1.5 mm CP	1
AM308-2018CP		62094001, 71102001	L299X	Nozzle - 1.8 mm CP	1
AM308-2020CP		62094001, 71102001	L300X	Nozzle - 2.0 mm CP	1
AM308-2030CP		62094002, 71102005	L301X	Nozzle - 3.0 mm CP	1
5	AM308-8810CP		L85X	Nozzle - 1.0 mm CP	1
	AM308-8812CP		L94X	Nozzle - 1.25 mm CP	1
	AM308-8815CP		L95X	Nozzle - 1.5 mm CP	1
	AM308-8817CP		L96X	Nozzle - 1.75 mm CP	1
	AM308-8820CP	74718816, 8249301	L38X	Nozzle - 2.0 mm CP	1
6	AM308-1905	71101905, 841143B	L30X	Nozzle, outer CP	1
7	AM308-S-20	S-20	AL90	O-ring (for nozzles)	10
8	AM308-AS-34	1AS-34	AL96	O-ring (for AM308-1905)	1

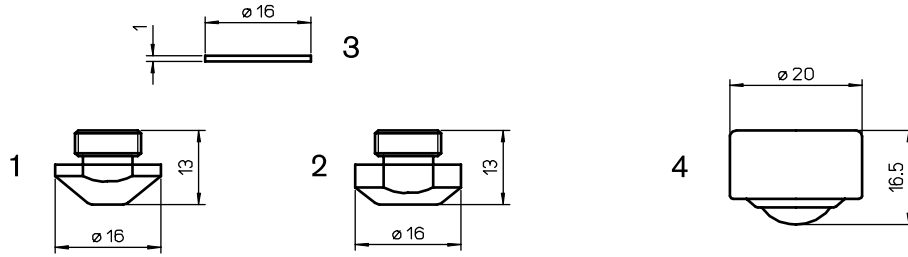

Consumables

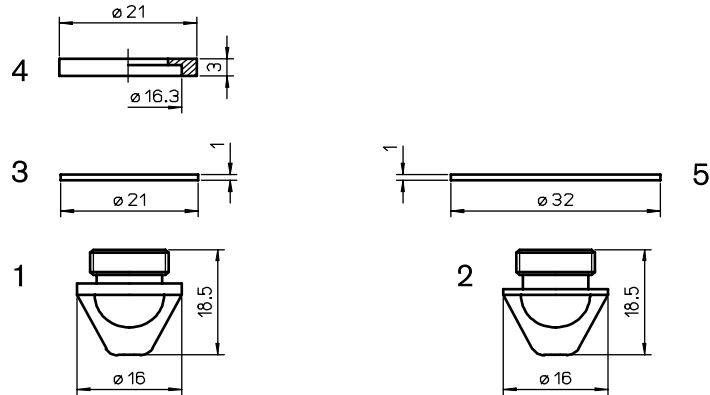
	Centricut part number	Reference number	Alternate reference	Description	Pkg qty
1	AM325-4010CP	62094006	L171X	Nozzle - 1.0 mm CP	1
	AM325-4010CPX	62094006	L30171X	Nozzle - 1.0 mm CP (10 pack)	10
	AM325-4006-1.3	62094006	L172X	Nozzle - 1.25 mm CP	1
	AM325-4125CPX	62094006	L30172X	Nozzle - 1.25 mm CP (10 pack)	10
	AM325-4006-1.5	62094006, 1507610	L173X	Nozzle - 1.5 mm CP	1
	AM325-4015CPX	62094006, 1507610	L30173X	Nozzle - 1.5 mm CP (10 pack)	10
	AM325-4175CP	62094006	L174X	Nozzle - 1.75 mm CP	1
	AM325-4175CPX	62094006	L30174X	Nozzle - 1.75 mm CP (10 pack)	10
	AM325-4006-2.0	62094006, 1507611	L27X	Nozzle - 2.0 mm CP	1
	AM325-4020CPX	62094006, 1507611	L3027X	Nozzle - 2.0 mm CP (10 pack)	10
	AM325-4025CP	62094006	L175X	Nozzle - 2.5 mm CP	1
	AM325-4025CPX	62094006	L30175X	Nozzle - 2.5 mm CP (10 pack)	10
	AM325-4006-3.0	62094008, 71102007	L28X	Nozzle - 3.0 mm CP	1
	AM325-4030CPX	62094008, 71102007	L3028X	Nozzle - 3.0 mm CP (10 pack)	10
2	AM325-1090CP	62094005	L750X	Nozzle - 1.0 mm CP	1
	AM325-1090CPX	62094005	L30750X	Nozzle - 1.0 mm CP (10 pack)	10
	AM325-4005CP	62094005	L751X	Nozzle - 1.25 mm CP	1
	AM325-4005CPX	62094005	L30751X	Nozzle - 1.25 mm CP (10 pack)	10
	AM325-4005-1.5	62094005, 71341515	L752X	Nozzle - 1.5 mm CP	1
	AM325-1515CPX	62094005, 71341515	L30752X	Nozzle - 1.5 mm CP (10 pack)	10
	AM325-1517CP	62094005, 71341515-1.75	L753X	Nozzle - 1.75 mm CP	1
	AM325-1517CPX	62094005, 71341515-1.75	L30753X	Nozzle - 1.75 mm CP (10 pack)	10
	AM325-4005-2.0	62094005, 71102006	L754X	Nozzle - 2.0 mm CP	1
	AM325-1520CPX	62094005, 71102006	L30754X	Nozzle - 2.0 mm CP (10 pack)	10
	AM325-1525CP	62094005	L755X	Nozzle - 2.5 mm CP	1
	AM325-1525CPX	62094005	L30755X	Nozzle - 2.5 mm CP (10 pack)	10
	AM325-1530CP	62094005, 71341515-3.0	L756X	Nozzle - 3.0 mm CP	1
	AM325-1530CPX	62094005, 71341515-3.0	L30756X	Nozzle - 3.0 mm CP (10 pack)	10
3	AM325-4006-R	62094006	AL107	Head protection disc - 16 mm (plastic)	1
4	AM325-0001		AL31	Work holder	1

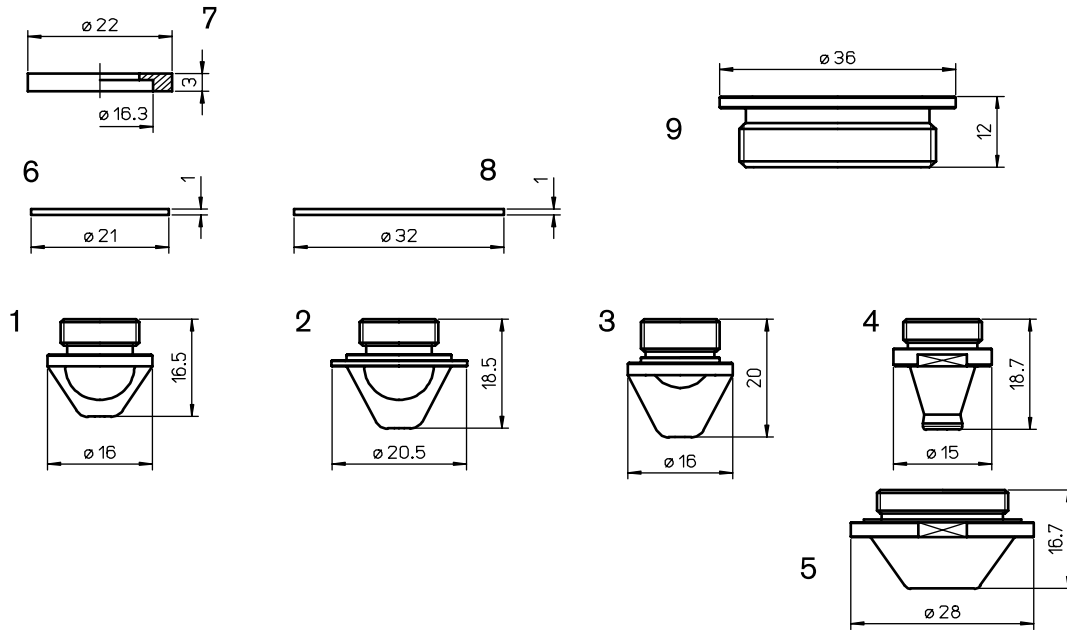

Consumables

	Centricut part number	Reference number	Alternate reference	Description	Pkg qty
1	AM325-0008CP		L760X	Nozzle - 0.8 mm CP	1
	AM325-0008CPX		L30760X	Nozzle - 0.8 mm CP (10 pack)	10
	AM325-545U-1.0	1664545U	L134X	Nozzle - 1.0 mm CP	1
	AM325-0010CPX	1664545U	L30134X	Nozzle - 1.0 mm CP (10 pack)	10
	AM325-545U-1.25	1664545U	L135X	Nozzle - 1.25 mm CP	1
	AM325-0125CPX	1664545U	L30135X	Nozzle - 1.25 mm CP (10 pack)	10
	AM325-545U-1.5	1664545U	L86X	Nozzle - 1.5 mm CP	1
	AM325-0015CPX	1664545U	L3086X	Nozzle - 1.5 mm CP (10 pack)	10
	AM325-545U-1.75	1664545U	L136X	Nozzle - 1.75 mm CP	1
	AM325-0175CPX	1664545U	L30136X	Nozzle - 1.75 mm CP (10 pack)	10
	AM325-545U-2.0	1664644U, 71341610	L137X	Nozzle - 2.0 mm CP	1
	AM325-0020CPX	1664644U, 71341610	L30137X	Nozzle - 2.0 mm CP (10 pack)	10
	AM325-545U-2.5	1664545U	L203X	Nozzle - 2.5 mm CP	1
	AM325-0025CPX	1664545U	L30203X	Nozzle - 2.5 mm CP (10 pack)	10
	AM325-4544U	1664645U, 71360142	L138X	Nozzle - 3.0 mm CP	1
	AM325-4544UX	1664645U, 71360142	L30138X	Nozzle - 3.0 mm CP (10 pack)	10
	AM325-0400CP		L339X	Nozzle - 4.0 mm CP	1
	AM325-0400CPX		L30339X	Nozzle - 4.0 mm CP (10 pack)	10
AM325-0050CP		L763X	Nozzle - 5.0 mm CP	1	
AM325-0050CPX		L30763X	Nozzle - 5.0 mm CP (10 pack)	10	
2	AM325-0001CP	Centricut design	L192X	Nozzle - 1.0 mm CP	1
	AM325-0001CPX	Centricut design	L30192X	Nozzle - 1.0 mm CP (10 pack)	10
	AM325-0002CP	Centricut design	L193X	Nozzle - 1.25 mm CP	1
	AM325-0002CPX	Centricut design	L30193X	Nozzle - 1.25 mm CP (10 Pack)	10
	AM325-0003CP	Centricut design	L194X	Nozzle - 1.5 mm CP	1
	AM325-0003CPX	Centricut design	L30194X	Nozzle - 1.5 mm CP (10 Pack)	10
	AM325-0004CP	Centricut design	L195X	Nozzle - 1.75 mm CP	1
	AM325-0004CPX	Centricut design	L30195X	Nozzle - 1.75 mm CP (10 pack)	10
	AM325-0005CP	Centricut design	L196X	Nozzle - 2.0 mm CP	1
	AM325-0005CPX	Centricut design	L30196X	Nozzle - 2.0 mm CP (10 pack)	10
	AM325-0006CP	Centricut design	L197X	Nozzle - 2.5 mm CP	1
	AM325-0006CPX	Centricut design	L30197X	Nozzle - 2.5 mm CP (10 pack)	10
AM325-0007CP	Centricut design	L198X	Nozzle - 3.0 mm CP	1	
AM325-0007CPX	Centricut design	L30198X	Nozzle - 3.0 mm CP (10 pack)	10	
3	AM325-325-1	71341614	AL1005	Head protection disc - 21 mm (plastic)	1
	AM325-1614	71341614	AL122	Head protection disc - 21 mm (Vespel®)	1
4	AM325-325-2	71341614	AL123	Head protection disc - 21 mm (ceramic)	1
5	AM325-9819	71369819	AL42	Head protection disc - 32 mm (plastic)	1



Consumables

	Centricut part number	Reference number	Alternate reference	Description	Pkg qty
1	AM325-0300CP		L338X	Nozzle - 3.0 mm CP short	1
	AM325-1500CP		L1067X	Nozzle - 1.5 mm CP large flange	1
2	AM325-2000CP		L1066X	Nozzle - 2.0 mm CP large flange	1
	AM325-3000CP		L1068X	Nozzle - 3.0 mm CP large flange	1
3	AM325-1770	71341770, 1667110	L1285X	Nozzle - 2.0 mm CP	1
	AM325-1730		L1287X	Nozzle - 3.0 mm CP	1
4	AM369-0001		L926X	Nozzle - 0.8 mm HP-X CP	1
	AM369-0002		L927X	Nozzle - 1.0 mm HP-X CP	1
	AM369-0003		L928X	Nozzle - 1.2 mm HP-X CP	1
	AM369-0009	71398902, 1034-00-5-1	L933X	Nozzle - 1.4 mm HP-X CP	1
	AM369-0004		L929X	Nozzle - 1.5 mm HP-X CP	1
	AM369-0005		L930X	Nozzle - 2.0 mm HP-X CP	1
	AM369-0006		L931X	Nozzle - 2.5 mm HP-X CP	1
	AM369-0007		L932X	Nozzle - 3.0 mm HP-X CP	1
5	AM369-0008		AL220X	Nozzle, outer HP-X CP	1
6	AM325-325-1	71341614	AL1005	Head protection disc - 21 mm (plastic)	1
	AM325-1614	71341614	AL122	Head protection disc - 21 mm (Vespel®)	1
7	AM325-325-2	71341614	AL123	Head protection disc - 21 mm (ceramic)	1
8	AM325-9819	71639819	AL42	Head protection disc - 32 mm (plastic)	1
9	AM367-0387 NEW		AL387	Ceramic spacer	1

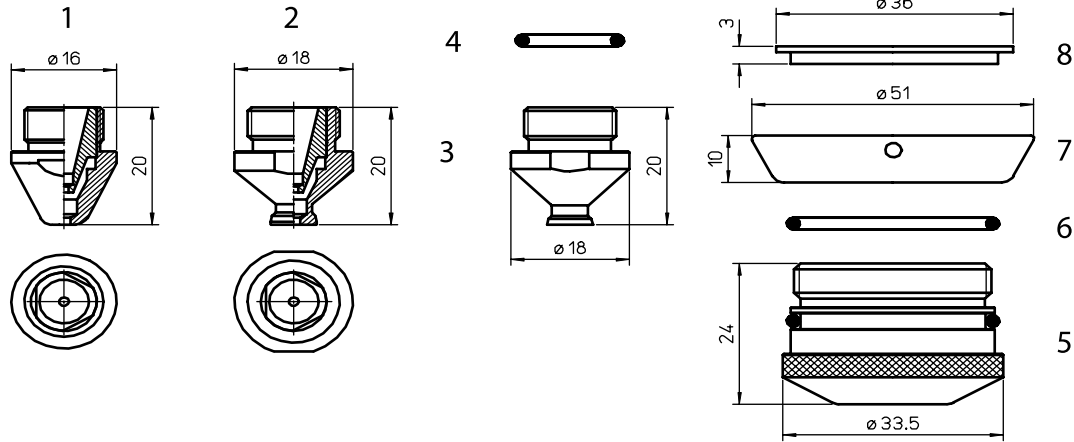

Consumables

	Centricut part number	Reference number	Alternate reference	Description	Pkg qty
1	AM326-9864-1.0	1669864, 7134162	L390X	Nozzle - 1.0 mm double CP	1
	AM326-9864-1.2	1669864, 7134162	L392X	Nozzle - 1.2 mm double CP	1
	AM326-9864-1.4	1669864, 7134162	L393X	Nozzle - 1.4 mm double CP	1
	AM326-9864-1.5	1669864, 7134162	L391X	Nozzle - 1.5 mm double CP	1
	AM326-9864CP	1669864, 7134162	L780X	Nozzle - 1.8 mm double CP	1
	AM326-9864-2.0	1669864, 7134162	L315X	Nozzle - 2.0 mm double CP	1
	AM326-9864-2.5	1669864, 7134162	L316X	Nozzle - 2.5 mm double CP	1
	AM326-9864-3.0	1669864, 7134163	L317X	Nozzle - 3.0 mm double CP	1
	AM326-4135CP	1669864, 7134162	L768X	Nozzle - 3.5 mm double CP	1
	AM326-4138CP	1669864, 7134162	L319X	Nozzle - 3.8 mm double CP	1
	AM326-9864-4.0	1669795, 71341681	L318X	Nozzle - 4.0 mm double CP	1
	2	AM326-1210CP	6551218, 71341682	L387X	Nozzle - 1.0 mm double CP
AM326-1212CP		6551218, 71341682	L386X	Nozzle - 1.2 mm double CP	1
AM326-1214CP		6551218, 71341682	L389X	Nozzle - 1.4 mm double CP	1
AM326-1218-1.5		6551218, 71341682	L388X	Nozzle - 1.5 mm double CP	1
AM326-1217CP		6551218, 71341682	L764X	Nozzle - 1.7 mm double CP	1
AM326-1218-2.0		6551218, 71341682	L320X	Nozzle - 2.0 mm double CP	1
AM326-1218-2.5		6551218, 71341682	L321X	Nozzle - 2.5 mm double CP	1
AM326-1218-3.0		6551218, 71341682	L322X	Nozzle - 3.0 mm double CP	1
AM326-1218-3.8		6551218, 71341682	L323X	Nozzle - 3.8 mm double CP	1
AM326-4140CP		6551218, 71341682	L330X	Nozzle - 4.0 mm double CP	1
AM326-0050CP	6551218, 71341682	L781X	Nozzle - 5.0 mm double CP	1	
3	AM326-6010CP	71366090	L384X	Nozzle - 1.0 mm CP	1
	AM326-6012CP	71366090	L765X	Nozzle - 1.2 mm CP	1
	AM326-6014CP	71366090	L766X	Nozzle - 1.4 mm CP	1
	AM326-6015CP	71366090	L385X	Nozzle - 1.5 mm CP	1
	AM326-6020CP	71366090	L324X	Nozzle - 2.0 mm CP	1
	AM326-6025CP	71366090	L325X	Nozzle - 2.5 mm CP	1
	AM326-6030CP	71366090	L326X	Nozzle - 3.0 mm CP	1
	AM326-6038CP	71366090	L327X	Nozzle - 3.8 mm CP	1
AM326-6040CP	71366090	L767X	Nozzle - 4.0 mm CP	1	
4	AM326-S-14	S-14	AL93	O-ring (for nozzles)	10
5	AM326-6452	71366452, 71341684, 6551148A	AL115X	Nozzle, outer CP	1
6	AM326-6453	71366453	AL94	O-ring (for AM326-6452)	10
7	AM326-6438	71366438	AL180	Guard nut	1
8	AM326-6437	71366437	AL181	Guard ring	1

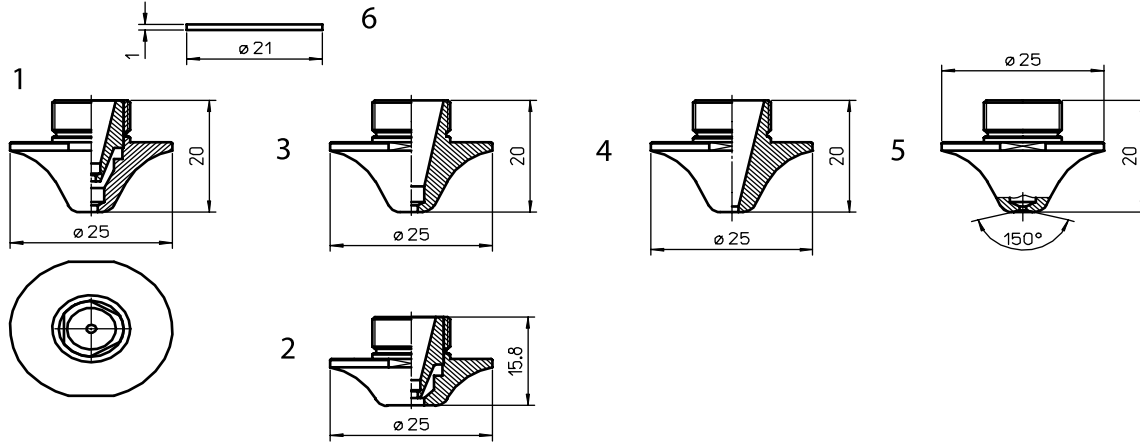

Consumables

	Centricut part number	Reference number	Alternate reference	Description	Pkg qty
1	AM343-2361-1.2	1572361	L585X	Nozzle - 1.2 mm double CP	1
	AM343-9813	71369813, 71502038, 71518550, 71341779	L586X	Nozzle - 1.4 mm double CP	1
	AM343-2361-1.7	1572361, 71518548, 1572380	L574X	Nozzle - 1.7 mm double CP	1
	AM343-2361-2.0	1572361	L587X	Nozzle - 2.0 mm double CP	1
	AM343-2361-2.5	71501059, 71515394, 71516789, 1576398	L584X	Nozzle - 2.5 mm double CP	1
	AM343-2361-3	1572361	L588X	Nozzle - 3.0 mm double CP	1
	AM343-9817	71501060, 71515395, 71516790, 1576399	L589X	Nozzle - 4.0 mm double CP	1
	AM367-1037		L1037X	Nozzle - 4.0 mm double CP (2.0 mm inner)	1
	AM343-2350CP	1572361	L583X	Nozzle - 5.0 mm double CP	1
	AM343-0569		L569X	Nozzle - 6.0 mm double CP	1
2	AM343-2340CPS		L565X	Nozzle - 4.0 mm double CP short	1
	AM343-2350CPS		L567X	Nozzle - 5.0 mm double CP short	1
	AM343-2360CPS		L568X	Nozzle - 6.0 mm double CP short	1
3	AM343-2362-0.8	1572362	L590X	Nozzle - 0.8 mm CP	1
	AM343-2362-1.0	1572362	L591X	Nozzle - 1.0 mm CP	1
	AM343-2362-1.2	71369812, 71341778	L592X	Nozzle - 1.2 mm CP	1
	AM343-2362-1.4	1572362	L593X	Nozzle - 1.4 mm CP	1
	AM343-2362-1.5	1572362, 1572368B	L597X	Nozzle - 1.5 mm CP	1
	AM343-2317CP	1572362	L575X	Nozzle - 1.7 mm CP	1
	AM343-2362-2.0	71515392	L594X	Nozzle - 2.0 mm CP	1
	AM343-0025CP		L572X	Nozzle - 2.5 mm CP	1
	AM343-2362-3.0	71501058, 71515393	L595X	Nozzle - 3.0 mm CP	1
	AM343-2362-4.0	1572362	L596X	Nozzle - 4.0 mm CP	1
4	AM343-0004CP		L1027X	Nozzle - 0.8 mm CP	1
	AM343-0005CP		L1028X	Nozzle - 1.0 mm CP	1
	AM343-0006CP		L1029X	Nozzle - 1.2 mm CP	1
	AM343-0007CP		L1030X	Nozzle - 1.4 mm CP	1
	AM343-0001CP		L599X	Nozzle - 1.5 mm CP	1
	AM343-0002CP		L598X	Nozzle - 2.0 mm CP	1
	AM343-0003CP		L571X	Nozzle - 3.0 mm CP	1
5	AM367-2008CP		L1024X	Nozzle - 0.8 mm CP w/concave	1
	AM367-2010CP		L1025X	Nozzle - 1.0 mm CP w/concave	1
	AM367-2037		L1026X	Nozzle - 1.2 mm CP w/concave	1
	AM367-2038	71502038, 1576396A	L1031X	Nozzle - 1.4 mm double CP w/concave	1
6	AM325-325-1	71341614	AL1005	Head protection disc - 21 mm (plastic)	1
	AM325-1614	71341614	AL122	Head protection disc - 21 mm (Vespel®)	1

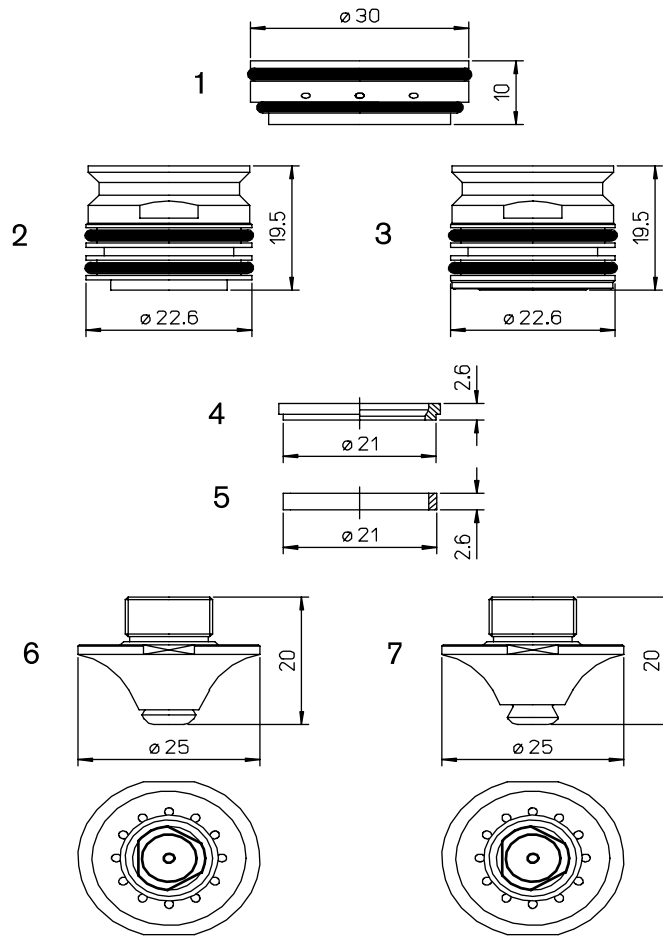
Consumables

	Centricut part number	Reference number	Alternate reference	Description	Pkg qty
1	AM367-2026	71502026	AL340	Insulator - PTFE*	1
2	AM367-2036	71502036	AL248	Nozzle adaptor w/8 holes	1
3	AM367-3036	71502036	AL348	Nozzle adaptor w/12 holes	1
	AM367-0001 (not shown)		AL268	O-ring	1
4	AM367-0853		AL233	O-ring - rigid	1
5	AM367-5853	71515853	AL234	Ring - PTFE*	1
6	AM386-2025CP	71502039	L1155X	Nozzle - 2.5 mm double CP w/holes	1
	AM386-2041CP	71502040	L1159X	Nozzle - 4.0 mm double CP w/holes	1
7	AM367-1014CP		L1041X	Nozzle - 1.4 mm double CP w/holes	1
	AM367-1017CP		L1043X	Nozzle - 1.7 mm double CP w/holes	1
	AM367-1020CP		L1044X	Nozzle - 2.0 mm double CP w/holes	1
	AM367-2039	71502039	L1045X	Nozzle - 2.5 mm double CP w/holes	1
	AM367-2040	71502040	L1049X	Nozzle - 4.0 mm double CP w/holes	1
	AM367-2050CP		L1050X	Nozzle - 5.0 mm double CP w/holes	1

*PolyTetraFluoroEthylene is a fluorocarbon-based polymer and is commonly abbreviated PTFE. The Teflon® brand of PTFE is manufactured only by DuPont and is not sold by Hypertherm. Hypertherm purchases other brands of PTFE from various high quality manufacturers.

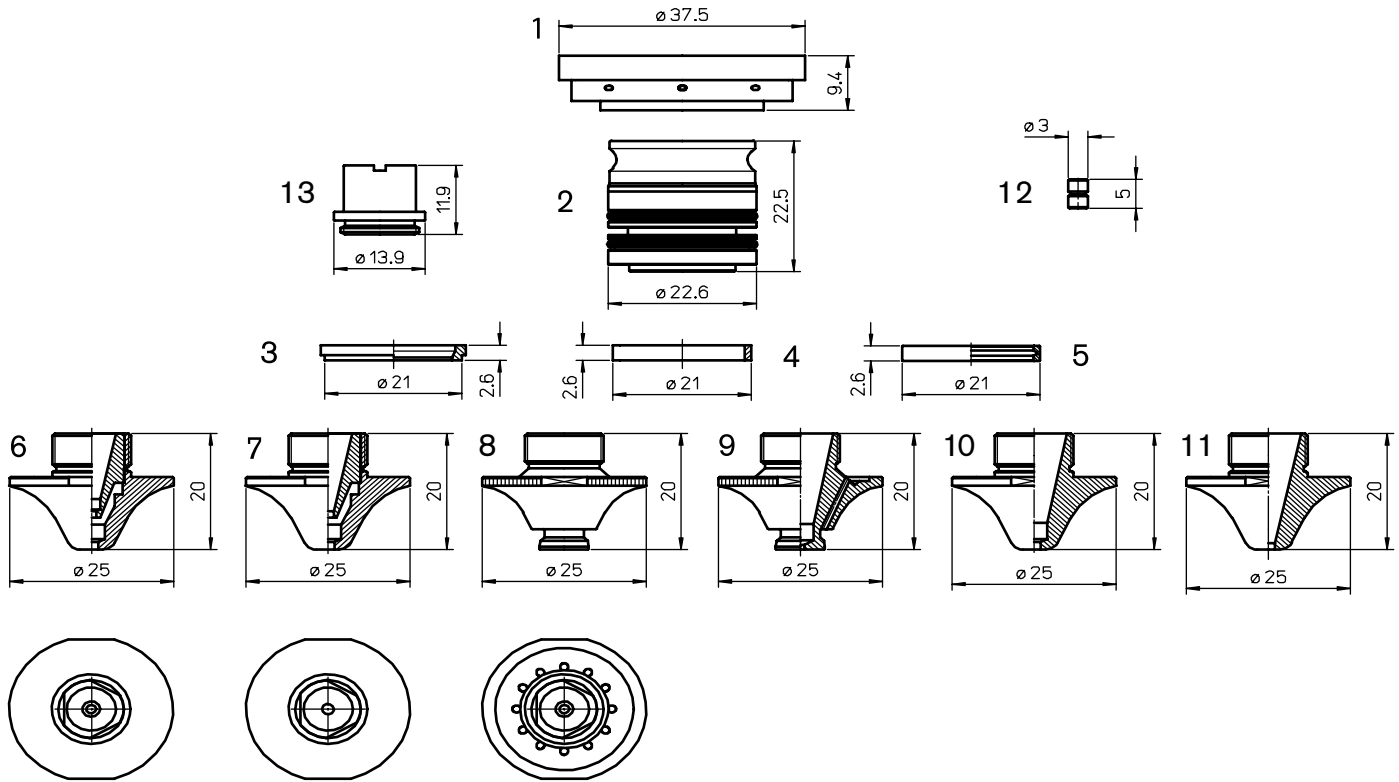

Consumables

	Centricut part number	Reference number	Alternate reference	Description	Pkg qty
1	AM367-2349	7973497, 71712349	AL372	Holder - PTFE*	1
2	AM367-0360	71712350, 7973459	AL360	Nozzle adaptor w/holes	1
3	AM367-0853		AL233	O-ring - rigid	1
4	AM367-5853	71515853	AL234	Ring - PTFE*	1
5	AM367-2340 NEW	71712340	AL361	Ring - PTFE* with groove	1
6	AM367-8550	71518550	L1401X	Nozzle - 1.4 mm double ECO Cut CP	1
	AM367-6789	71516789	L1403X	Nozzle - 2.5 mm double ECO Cut CP	1
	AM367-6790	71516790	L1405X	Nozzle - 4.0 mm double ECO Cut CP	1
7	AM367-6791CP	7151690	L1406X	Nozzle - 4.0 mm double AL CP	
8	AM367-1352CP		L1352X	Nozzle - 1.4 mm double WACS CP	1
	AM367-1353CP		L1353X	Nozzle - 1.7 mm double WACS CP	1
	AM367-1354CP		L1354X	Nozzle - 2.0 mm double WACS CP	1
	AM367-1355CP	71712335	L1355X	Nozzle - 2.5 mm double WACS CP	1
	AM367-1158CP	71712336, 71461158	L1359X	Nozzle - 4.0 mm double WACS CP	1
9	AM367-2336 NEW	71712336, 71461158	L1568X	Nozzle - S1.2W WACS CP	1
10	AM367-1407CP	71502037	L1407X	Nozzle - 1.2 mm ECO Cut CP	1
11	AM367-1410CP		L1410X	Nozzle - 1.4 mm ECO Cut CP	1
	AM367-1411CP	71501056	L1411X	Nozzle - 1.5 mm ECO Cut CP	1
	AM367-1412CP	71501057	L1412X	Nozzle - 2.0 mm ECO Cut CP	1
	AM367-1413CP	71516788	L1413X	Nozzle - 3.0 mm ECO Cut CP	1
12	AM367-2344	71712344	AL359	Locating pin	1
13	AM367-6438	71716438	AL392	Inner for adapter	1

*PolyTetraFluoroEthylene is a fluorocarbon-based polymer and is commonly abbreviated PTFE. The Teflon® brand of PTFE is manufactured only by DuPont and is not sold by Hypertherm. Hypertherm purchases other brands of PTFE from various high quality manufacturers.

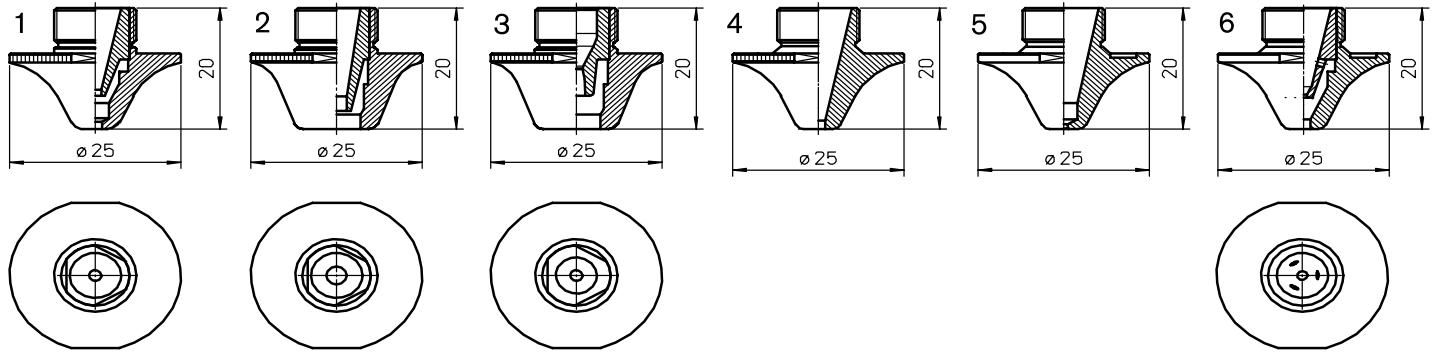
Consumables

	Centricut part number	Reference number	Alternate reference	Description	Pkg qty
1	AM367-1727CP		L1415XH	Nozzle - 2.5 mm double Clean Cut CP	1
	AM367-1728	71341728	L1416XH	Nozzle - 4.0 mm double Clean Cut CP	1
2	AM367-1717CP		L1417XH	Nozzle - 5.0 mm double Clean Cut CP	1
	AM367-1718CP		L1418XH	Nozzle - 6.0 mm double Clean Cut CP	1
	AM367-1729CP	71341729	L1419XH	Nozzle - 7.0 mm double Clean Cut CP	1
3	AM367-1770CP	71712692	L1420XH	Nozzle - 7.0 mm double Silky Cut CP	1
4	AM367-1421CP		L1421XH	Nozzle - 1.5 mm Clean Cut CP	1
	AM367-1422CP	71502043	L1422XH	Nozzle - 2.0 mm Clean Cut CP	1
	AM367-1423CP	71502044	L1423XH	Nozzle - 3.0 mm Clean Cut CP	1
	AM367-1424CP	NEW	L1424XH	Nozzle - 2.5 mm Clean Cut CP	1
5	AM367-1560	NEW	L1560X	Nozzle - 0.8 mm Fe CP	1
	AM367-1561	NEW	L1561X	Nozzle - 1.0 mm Fe CP	1
	AM367-1562	NEW	L1562X	Nozzle - 1.2 mm Fe CP	1
	AM367-1563	NEW	L1563X	Nozzle - 1.4 mm Fe CP	1
6	AM367-0022	NEW	L1645X	Nozzle - double 2.0 mm Fe CP	1
	AM367-0025	NEW	L1646X	Nozzle - double 2.5 mm Fe CP	1

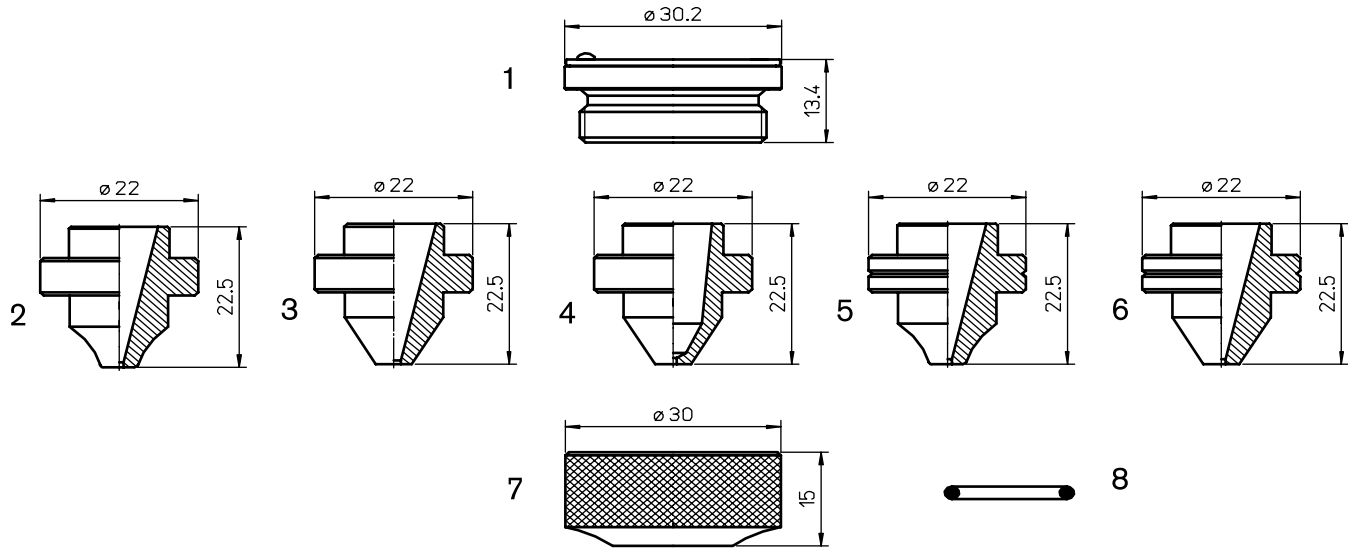

LC 3015 XI NT

Consumables

	Centricut part number	Reference number	Alternate reference	Description	Pkg qty
1	MB334-0001	P0594-860-00001	AL267	Nozzle holder - IT HP2 MZP/MEL	1
2	AM387-0001	71800016A0, BQ933D283H01	L1126	Nozzle - 1.0 mm w/radius no grooves	1
3	AM326-0018	71800018, BQ943D157H01	L1134	Nozzle - 1.5 mm	1
	AM326-0017		L1131	Nozzle - 1.7 mm	1
	AM326-0019	71800019, BQ943D157H02	L1135	Nozzle - 2.0 mm	1
	AM326-0020	71800020, BQ943D157H03	L1136	Nozzle - 2.5 mm	1
	AM326-0021	71800021, BQ943D157H04	L1137	Nozzle - 3.0 mm	1
	AM326-0022	71800022, BQ943D596H01	L1138	Nozzle - 3.5 mm	1
	AM326-0023		L1139	Nozzle - 4.0 mm	1
	AM326-0024CP	71800109, BQ943D714H01, W18Q94371401	L1140X	Nozzle - 4.0 mm CP (focus point)	1
4	AM387-0016	71800016, BQ943D897H01, W18Q94389701	L1125	Nozzle - 1.0 mm	1
	AM387-1901	W18Q93309101	L1128	Nozzle - 2.5 mm	1
	AM387-1902	W18Q93309102	L1129	Nozzle - 3.0 mm	1
5	AM387-0017	71800017, BQ943D269H01, W18Q93326901	L1130	Nozzle - 1.2 mm w/radius	1
6	AM387-2701	W18Q93302701	L1132	Nozzle - 1.7 mm	1
7	AM367-0269	71800026, BQ933D94H01	AL269	Nozzle nut short	1
8	MB334-W290	W290	AL388	O-ring	1

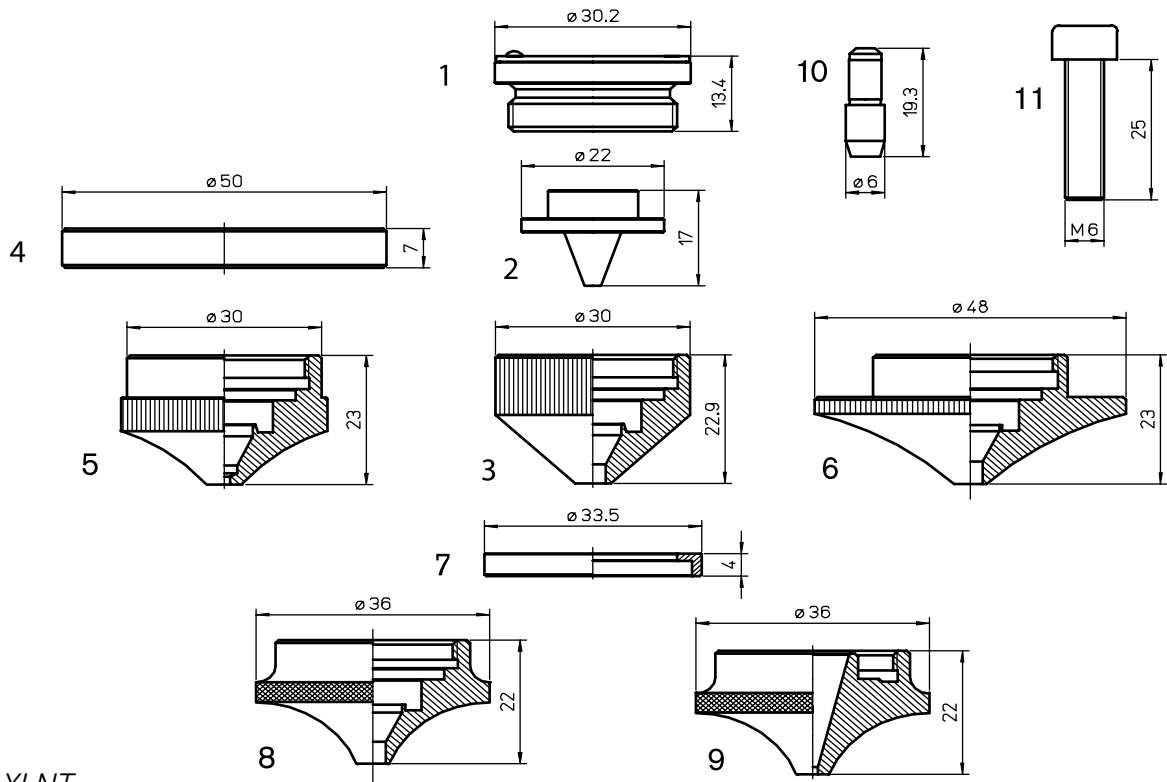

LC 3015 XI NT

Consumables

	Centricut part number	Reference number	Alternate reference	Description	Pkg qty
1	MB334-0001	P0594-860-00001	AL267	Nozzle holder - IT HP2 MZP/MEL	1
2	AM387-0023	71800023, BQ943D156H01	L1119	Nozzle - double insert - 8 hole 1.5 mm	1
	AM387-0024	71800024, BQ943D156H03	L1123	Nozzle - double insert - 24 hole 1.5 mm	1
	AM387-0025		L1120	Nozzle - double insert - 8 hole 2.0 mm	1
	AM387-0026		L1124	Nozzle - double insert - 24 hole 2.0 mm	1
3	MB316-269S	71800027, BQ933D221H04, P0593-860-00001	AL238	Shield cap - short	1
	MB316-269SCP		AL238X	Shield cap - short CP	1
4	AM416-0001		AL297	Ring (plastic)	1
5	AM416-0002		AL302	Nozzle - 1.7 mm (outer)	1
	AM416-0003		AL303	Nozzle - 2.0 mm (outer)	1
	AM416-0004		AL304	Nozzle - 2.5 mm (outer)	1
	AM416-0005		AL305	Nozzle - 3.0 mm (outer)	1
	AM416-0006		AL306	Nozzle - 4.0 mm (outer)	1
	6	MB316-0440	BQ933D044H01, 71800101, W18Q93304401	AL266	Nozzle, outer - high speed pierce
7	AM416-0155T	71800155TF, BQ023D021H01	AL341-T	Insulation ring - PTFE*	1
	AM416-0155A	71800155AL, BQ023D021H01	AL341-A	Insulation ring - Aluminum	1
8	AM416-2197	71802197, BQ933D044H01	AL270	Nozzle, outer	1
9	AM416-5400	7180015400, BQ023D020H01	L1262	Nozzle - 1.7 mm high speed pierce	1
10	AM416-0009	71800009, P921K000P25, JPZA5-6	AL345	Safety pin	1
11	AM416-A005	71800008, L2490A005	AL346	Safety screw	1

*PolyTetraFluoroEthylene is a fluorocarbon-based polymer and is commonly abbreviated PTFE. The Teflon® brand of PTFE is manufactured only by DuPont and is not sold by Hypertherm. Hypertherm purchases other brands of PTFE from various high quality manufacturers.

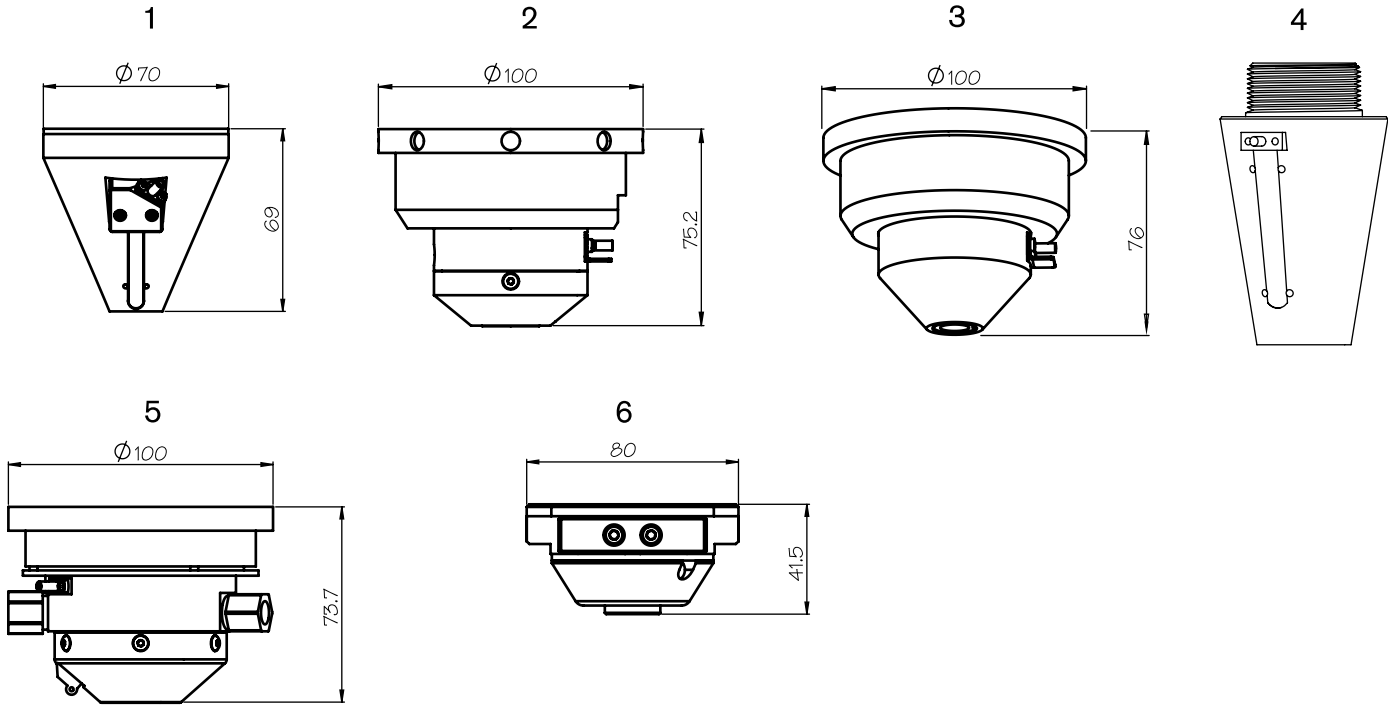
Sensor cones

	Centricut part number	Reference number	Alternate reference	Description	Pkg qty
Sensor cone repair					
	AM999-HS95 (not shown)	71341621	567011	Sensor repair HS95 (86 mm x 69 mm)	1
1	AM999-HS95M	71360091		Sensor repair (mini) (70 mm x 69 mm)	1
2	AM999-ECO	71399107		Sensor repair ECO	1
3	AM999-HS98	71341690		Sensor repair HS98	1
4	AM999-L3015C	71374509		Sensor repair L3015C	1
5	AM999-HPX			Sensor repair HPX	1
6	AM999-HPL	74810277		Sensor repair HP-L (red)	1
	AM999-WACS (not shown)	71502035		Sensor repair HP-X WACS	1
	AM999-KNF (not shown)	HPX-KNF		Air knife - HPX sensor	1
New sensor cones					
2	AM343-9107	Amada ECO cone		Sensor cone - ECO	1
3	AM343-1690 NEW	71341690		Sensor cone - HS98	1

Sensor repairs available in select regions only.

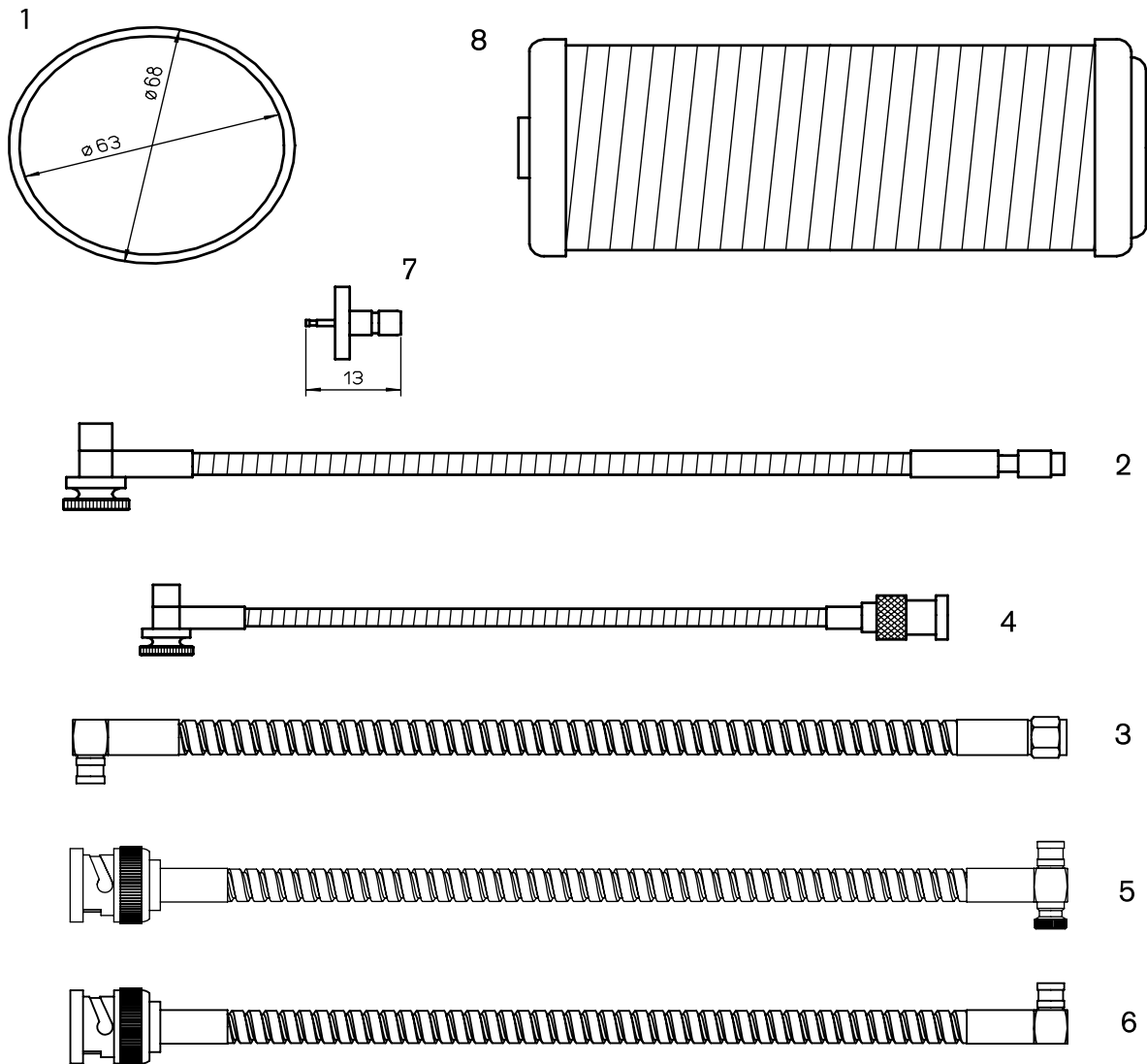
Sensor cables and accessories

	Centricut part number	Reference number	Alternate reference	Description	Pkg qty
1	AM313-0004		AL56	Gasket - PTFE* sensor head	1
2	AM313-1901	71341630	AL200	Sensor cable - HS-5 305 mm	1
3	AM313-1901A	71341630		Sensor cable - HS-5 305 mm (premium)	1
4	AM308-8965	71398965	AL260	Sensor cable - HS-15 F.O. 305 mm	1
5	AM308-8965A	71398965		Sensor cable - armored 305 mm (premium)	1
6	AM313-9851A	71369851		Sensor cable - armored 203 mm (premium)	1
7	AM308-0001		AL263	Sensor cable connector	1
8	AM313-2023	71232023		Filter - vacuum pump	1

*PolyTetraFluoroEthylene is a fluorocarbon-based polymer and is commonly abbreviated PTFE. The Teflon® brand of PTFE is manufactured only by DuPont and is not sold by Hypertherm. Hypertherm purchases other brands of PTFE from various high quality manufacturers.

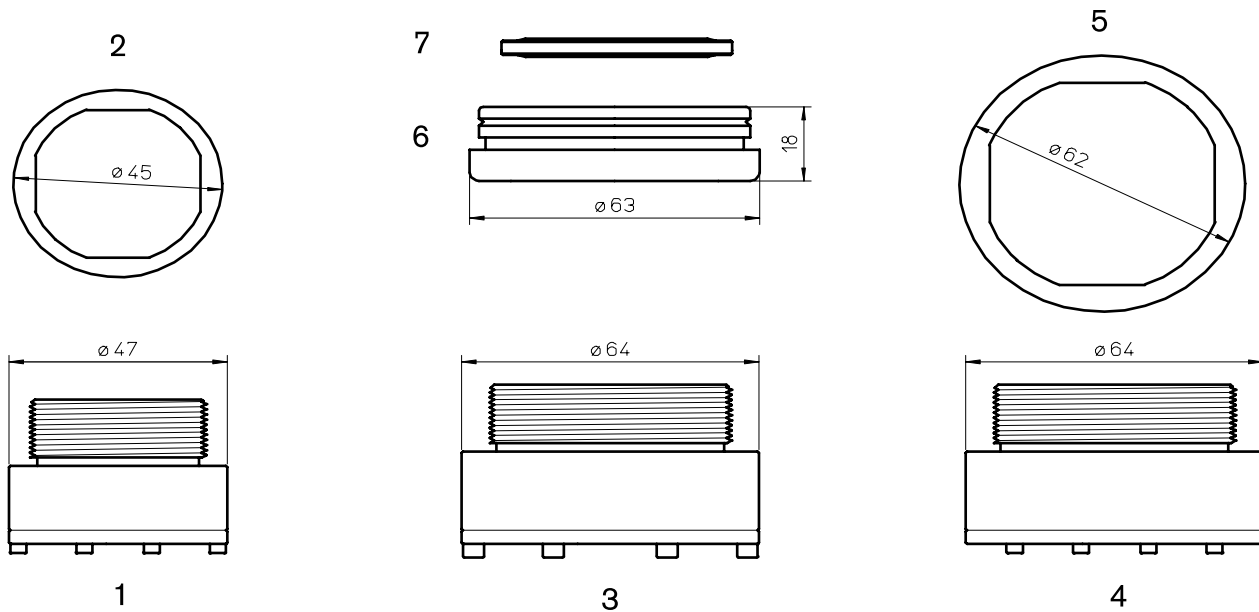

Centricut lens housings and assemblies

	Centricut part number	Reference number	Alternate reference	Description	Pkg qty
1	AM313-0200	T07135390200	LT85	Lens assembly - PLX 1.5" dia 5.0" F.L. .300" ET	1
	AM313-6900	MD7136096900	LT95	Lens assembly - PLX 1.5" dia 7.5" F.L. .300" ET	1
	AM313-0001		A100	Lens housing - 1.5" dia	1
2	AM313-0005	71360261	AL52	Gasket - PTFE* 1.5" lens housing	1
3	AM313-6182	MD7110965200, 71366182	LT105	Lens assembly - PLX 2.0" dia 5.0" F.L. .300" ET	1
	AM313-8467	MD7110965300, 71368467	LT110	Lens assembly - PLX 2.0" dia 7.5" F.L. .300" ET	1
	AM313-5400	MD7110965400	LT115	Lens assembly - PLX 2.0" dia 10.0" F.L. .300" ET	1
	AM313-0002		A105	Lens housing - 2.0" dia	1
4	AM313-8000	T07110968000	LT205	Lens assembly - PLX 1.5" dia 5.0" F.L. F.O. .300" ET	1
	AM313-8100	T07110968100	LT210	Lens assembly - PLX 1.5" dia 7.5" F.L. F.O. .300" ET	1
	AM313-0003		A107	Lens housing - 1.5" aluminum, Gemini	1
5	AM313-9513	71361393	AL149	Gasket - PTFE* 2.0" lens housing	1
6	AM313-1305	71501072	LT305	Lens assembly - PLX 1.5" dia 5.0" F.L. .300" ET	1
	AM313-1310	71501070	LT310	Lens assembly - PLX 1.5" dia 7.5" F.L. .300" ET	1
	AM313-1315	71502030	LT315	Lens assembly - PLX 1.5" dia 10.0" F.L. .300" ET	1
	AM313-50F0		A109	Lens housing - 5.0" FO NT	1
	AM313-75F0		A112	Lens housing - 7.5" FO NT	1
7	AM313-1071	71501071	AL249	Gasket	1

*PolyTetraFluoroEthylene is a fluorocarbon-based polymer and is commonly abbreviated PTFE. The Teflon® brand of PTFE is manufactured only by DuPont and is not sold by Hypertherm. Hypertherm purchases other brands of PTFE from various high quality manufacturers.

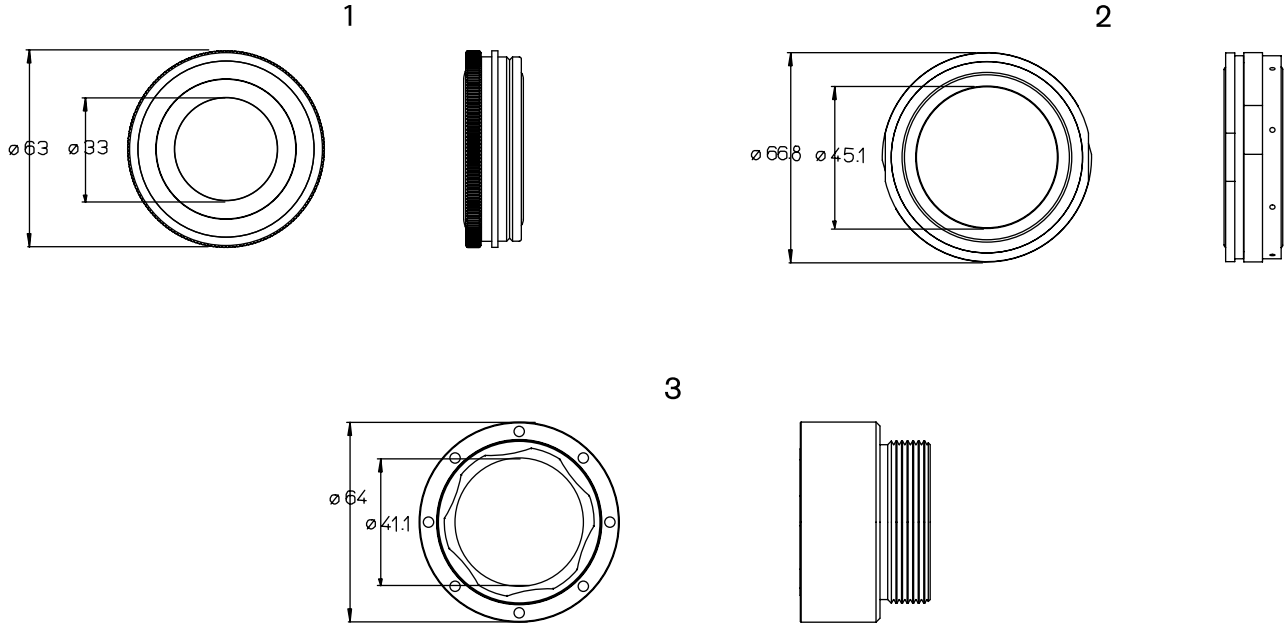

Simple mount lens housings (lens not included)

	Centricut part number	Reference number	Alternate reference	Description	Pkg qty
1	AM313-50NT			Simple mount 5.0" FL for NT	1
	AM313-75NT			Simple mount 7.5" FL for NT	1
2	AM313-EZ50F1			Simple mount 5" FL lens for F1	1
	AM313-EZ75F1			Simple mount for 7.5" for F1	1
	AM313-EZ10F1			Simple mount 10" FL lens for F1	1
3	AM313-1515			Simple mount 1.5" for 1.5" lens	1
	AM313-2015			Simple mount 2.0" for 1.5" lens	1
	AM313-2020			Simple mount 2.0" for 2.0" lens	1

Still sending lenses out for remount?

Save time and money with the Simple Mount for Amada laser cutting systems. The design allows replacement at the machine without the need for professional remounting or special tools.

Saves money

- Replace only the lens, not the mount
- Eliminate the need for multiple lens mounts

Saves time

- Easier lens cleaning
- No special tools required



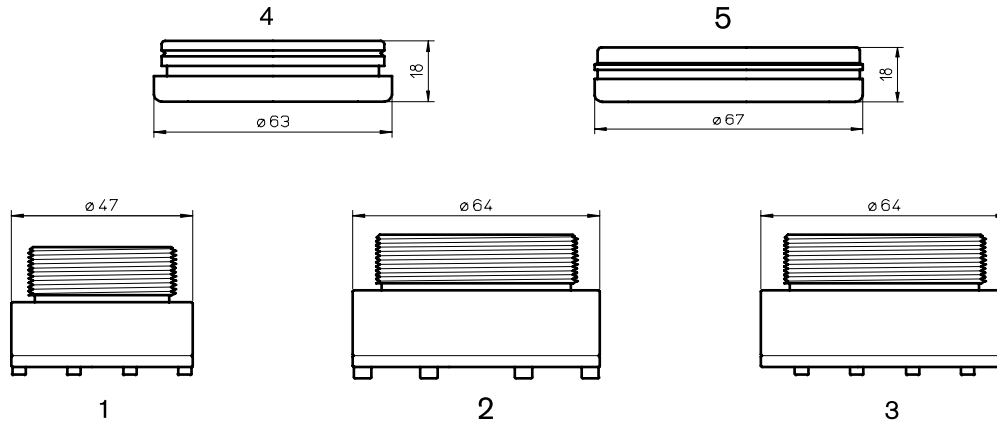

Optics

	Centricut part number	Reference number	Type	Diameter	Focal length	Edge thickness
Mounted lenses						
1	AM313-0306	81140306	PLX	1.5"	5.00"	.300"
	AM313-0400	81140400	PLX	1.5"	7.50"	.300"
2	AM313-9830	71369830	PLX	1.5"	5.00"	.300"
	AM313-9831	71369831	PLX	1.5"	7.50"	.300"
3	AM313-0307	81140307	PLX	2.0"	5.00"	.380"
	AM313-0186	81140186	PLX	2.0"	7.50"	.380"
4	AM313-1216	901216A	PLX	1.5"	5.00"	.300"
	AM313-8662	578662	PLX	1.5"	5.00"	.300"
	AM313-1215	901215A	PLX	1.5"	7.50"	.300"
	AM313-3110		PLX	1.5"	7.50"	.300"
5	AM313-10F1 NEW	680154-001	PLX	2.0"	10.00"	.380"
	AM313-50F1	71710059	PLX	2.0"	5.00"	.380"
	AM313-75F1	71710030	PLX	2.0"	7.50"	.380"
	AM313-0221	81140221	PLX	1.5"	3.75"	.300"
Ultra low absorption – mounted lenses						
1	AM313-0400ULA	81140400	PLX	1.5"	7.50"	.300"
2	AM313-9830ULA	71369830	PLX	1.5"	5.00"	.300"
	AM313-9831ULA	71369831	PLX	1.5"	7.50"	.300"
3	AM313-0307ULA	81140307	PLX	2.0"	5.00"	.380"
	AM313-0186ULA	81140186	PLX	2.0"	7.50"	.380"
4	AM313-1216ULA	901216A	PLX	1.5"	5.00"	.300"
	AM313-1215ULA	901215A	PLX	1.5"	7.50"	.300"

Non-mounted lenses						
	AM313-0305	81140305	PLX	1.1"	5.00"	.160"
	AM313-6602 NEW	726602	PLX	1.1"	7.50"	.160"
	AM313-0221NM	81140221	PLX	1.5"	3.75"	.300"
	AM313-0221	81140221	PLX	1.5"	3.75"	.300"
	AM313-0306NM	81140306	PLX	1.5"	5.00"	.300"
	AM313-1072	71501072	PLX	1.5"	5.00"	.300"
	AM313-0400NM	81140400	PLX	1.5"	7.50"	.300"
	AM313-1019NM	306068	PLX	1.5"	7.50"	.300"
	AM313-7070	71501070	PLX	1.5"	7.50"	.300"
	AM313-0307NM	81140307	PLX	2.0"	5.00"	.380"
	AM313-0186NM	81140186	PLX	2.0"	7.50"	.380"
Ultra low absorption – non-mounted lenses						
	AM313-0306NUL	81140306	PLX	1.5"	5.00"	.300"
	AM313-1072NUL	71501072	PLX	1.5"	5.00"	.300"
	AM313-7070NUL	71501070	PLX	1.5"	7.50"	.300"
	AM313-0400NUL	81140400	PLX	1.5"	7.50"	.300"
	AM313-0307NUL	81140307	PLX	2.0"	5.00"	.380"
	AM313-0186NUL	81140186	PLX	2.0"	7.50"	.380"

Centricut part number	Reference number	Type	Material	Diameter	Edge thickness	S1
Zero phase shift mirrors and total reflectors						
AM313-7524	647487, 47524-010	MMR	SI	1.5"	.375"	
AM313-8083	71198083	MMR	SI	2.0"	.200"	
AM313-7562	587562	MMR	CU	2.0"	.394"	4.3MCX
AM313-2861	612861	MMR	CU	2.0"	.394"	5.3MCX
AM313-4552 NEW	631246-117, 71374552	COL	CU	2.0"	.250"	6.0M
AM313-0562 NEW	631245-117, 71510562	COL	CU	2.0"	.250"	7.5M
AM313-4946 NEW	209379	TRZ	CU	2.0"	.394"	10MCC
AM313-4945 NEW	291218	TRZ	CU	2.0"	.394"	15MCX
AM313-8312	478312, 614835	TRZ	SI	3.0"	.250"	
AM313-8089	71198089	TRZ	SI	2.0"	.200"	
AM313-2093	87093	TRZ	SI	2.0"	.200"	
AM313-0064	270064	ZPS	SI	1.5"	.200"	PO-DEMRR
AM313-5252	805252	ZPS	SI	2.0"	.200"	
AM313-8084	61054, 71198084	ZPS	SI	3.0"	.200"	
AM313-8092	71198092	ZPS	SI	3.0"	.250"	
AM313-0397	71360397, 614835	ZPS	SI	3.0"	.250"	
AM313-7882 NEW		MMR	CU	2.0"	.394"	3MCX
AM313-2098 NEW		MMR	CU	2.0"	.394"	4.6MCC
AM313-3739	643739	PO	MO	2.0"	.200"	
AM313-3962	483962	MMR	CU	2.0"	.394"	5.7MCX
AM313-0641	690641	MMR	CU	2.0"	.394"	6.0MCC
AM313-4619	71514619, 383098	MMR-A	CU	2.0"	.394"	6.0MCX
AM313-4620	71514620, 867137	MMR-A	CU	2.0"	.394"	5.7MCX

Centricut part number	Reference number	Alternate reference	Description	Pkg qty	S2
Windows					
AM313-LSA		LSA 2.0	Window for 2.0 lens	1	9MCX

Centricut part number	Reference number	Material	Diameter	Edge thickness	S1/Reflectivity	
Output couplers						15MCX
AM313-8081	71198081	ZNSE	1.1"	.236"	20MCC-60%	10MCX
AM313-2134	182134	ZNSE	1.1"	.236"	20MCC-60%	50MCX
AM313-1656	641656	ZNSE	1.1"	.236"	PO-70%	
AM313-8093	71198093	ZNSE	1.5"	.315"	35MCC-60%	51.6MCX
AM313-5303	70503	ZNSE	1.5"	.315"	20MCC-40%	15MCX
AM313-3827 NEW	903827	ZNSE	1.5"	.315"	20MCC	10MCX
AM313-7405	497405	ZNSE	1.5"	.315"	20MCC-50%	
AM313-6469	426469	ZNSE	1.5"	.315"	25MCC-50%	
AM313-4977	204977	ZNSE	1.5"	.315"	35MCC	
Rear mirrors						
AM313-8087	71198087	GE	1.1"	.236"	20MCC-99.5%	
AM313-8094	71198094	GE	1.5"	.315"	35MCC-99.5%	
AM313-7088	667088	GE	1.5"	.315"	20MCC-99.5%	
AM313-9165		GE	1.5"	.315"	20MCC-99.5%	

Optics care

Centricut part number	Reference number	Description	Pkg qty
TR300-6452	N/A	Lens cleaning paper, Tiffen – 50 piece	1
AM313-SC50 NEW	SC50	Lens cleaning paper, Tresor – 50 piece	1
TR300-1115		Lens cleaning pre-cut cotton – 80 piece	1
TR300-SC20		Cotton swab – 20 piece	1
TR300-1010	AL1010	Dropper, lens cleaning fluid	1
TR300-255	AL255	Loupe, magnifying	1
TR300-271	AL271	Base, lens maintenance	1
TR300-7388	787388	Mirror polish (250 ml)	1
AM313-1260 NEW	351260-009	Lens Polarizing Filter – 1.5"	1
AM313-1280 NEW	351280-009	Lens Polarizing Filter – 2.0"	1
MZ335-115	ALI115/M	Indium wire – .8 mm x 125 mm (1.5" lens)	1
MZ335-120	ALI120/M	Indium wire – .8 mm x 160 mm (2.0" lens)	1

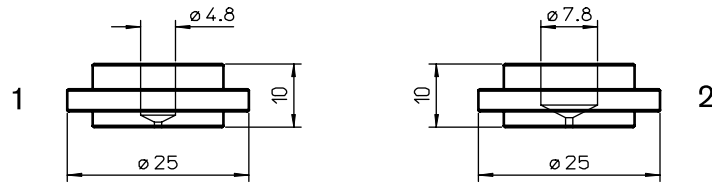
Consumables

	Centricut part number	Reference number	Alternate reference	Description	Pkg qty
1	BE370-0001		L50	Nozzle - 0.8 mm	1
	BE370-0002		L58	Nozzle - 1.0 mm	1
	BE370-0003		L59	Nozzle - 1.2 mm	1
	BE370-0004		L97	Nozzle - 1.5 mm	1
	BE370-0005		L231	Nozzle - 2.0 mm	1
2	BE371-0001		L242	Nozzle - 0.8 mm	1
	BE371-0002		L243	Nozzle - 1.0mm	1
	BE371-0003		L244	Nozzle - 1.2 mm	1
	BE371-0004		L245	Nozzle - 1.5 mm	1
	BE371-0005		L246	Nozzle - 2.0 mm	1

Optics

Centricut part number	Reference number	Material	Diameter	Edge thickness	S1
Phase shift mirrors					
BE370-3833	893833	SI	2.0"	.200"	

Optics care

Centricut part number	Reference number	Description	Pkg qty
TR300-6452	N/A	Lens cleaning paper, Tiffen - 50 piece	1
AM313-SC50 NEW	SC50	Lens cleaning paper, Tresor - 50 piece	1
TR300-1115		Lens cleaning pre-cut cotton - 80 piece	1
TR300-SC20		Cotton swab - 20 piece	1
TR300-1010	AL1010	Dropper, lens cleaning fluid	1
TR300-255	AL255	Loupe, magnifying	1
TR300-271	AL271	Base, lens maintenance	1
TR300-7388	787388	Mirror polish (250 ml)	1
AM313-1280 NEW	351260-009	Lens Polarizing Filter - 1.5"	1
AM313-1280 NEW	351280-009	Lens Polarizing Filter - 2.0"	1

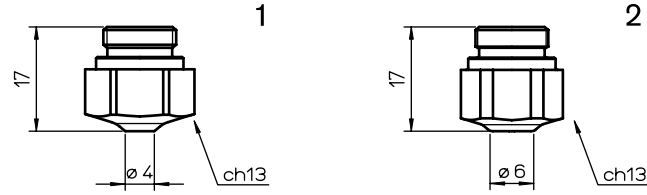

Consumables

	Centricut part number	Reference number	Alternate reference	Description	Pkg qty
1	BY310-4277	3-04277, HK08	L674	Nozzle - 0.8 mm HD	1
	BY310-4277X	3-04277, HK08	L30674	Nozzle - 0.8 mm HD (10 pack)	10
	BY310-1910	3-01910, HK10	L72	Nozzle - 1.0 mm HD	1
	BY310-1910X	3-01910, HK10	L3072	Nozzle - 1.0 mm HD (10 pack)	10
	BY310-1911	3-01911, HK12	L121	Nozzle - 1.25 mm HD	1
	BY310-1911X	3-01911, HK12	L30121	Nozzle - 1.25 mm HD (10 pack)	10
	BY310-1912	3-01912, HK15	L73	Nozzle - 1.5 mm HD	1
	BY310-1912X	3-01912, HK15	L3073	Nozzle - 1.5 mm HD (10 pack)	10
	BY310-1913	3-01913, HK17	L122	Nozzle - 1.75 mm HD	1
	BY310-1913X	3-01913, HK17	L30122	Nozzle - 1.75 mm HD (10 pack)	10
	BY310-1910CP	3-01910, HK10	L72X	Nozzle - 1.0 mm HD CP	1
	BY310-1910CPX	3-01910, HK10	L3072X	Nozzle - 1.0 mm HD CP (10 pack)	10
	BY310-1911CP	3-01911, HK12	L121X	Nozzle - 1.25 mm HD CP	1
	BY310-1911CPX	3-01911, HK12	L30121X	Nozzle - 1.25 mm HD CP (10 pack)	10
	BY310-1912CP	3-01912, HK15	L73X	Nozzle - 1.5 mm HD CP	1
	BY310-1912CPX	3-01912, HK15	L3073X	Nozzle - 1.5 mm HD CP (10 pack)	10
	BY310-1913CP	3-01913, HK17	L122X	Nozzle - 1.75 mm HD CP	1
	BY310-1913CPX	3-01913, HK17	L30122X	Nozzle - 1.75 mm HD CP (10 pack)	10
2	BY310-1914	3-01914, HK20	L123	Nozzle - 2.0 mm HD	1
	BY310-1914X	3-01914, HK20	L30123	Nozzle - 2.0 mm HD (10 pack)	10
	BY310-1915	3-03854, HK25	L140	Nozzle - 2.5 mm HD	1
	BY310-1915X	3-03854, HK25	L30140	Nozzle - 2.5 mm HD (10 pack)	10
	BY310-6112	3-06112, HK30	L265	Nozzle - 3.0 mm HD	1
	BY310-6112X	3-06112, HK30	L30265	Nozzle - 3.0 mm HD (10 pack)	10
	BY310-0035	HK35	L700	Nozzle - 3.5 mm HD	1
	BY310-0035X	HK35	L30700	Nozzle - 3.5 mm HD (10 pack)	10
	BY310-0040	HK40	L701	Nozzle - 4.0 mm HD	1
	BY310-0040X	HK40	L30701	Nozzle - 4.0 mm HD (10 pack)	10
	BY310-1914CP	3-01914, HK20	L123X	Nozzle - 2.0 mm HD CP	1
	BY310-1914CPX	3-01914, HK20	L30123X	Nozzle - 2.0 mm HD CP (10 pack)	10
	BY310-1915CP	3-03854, HK25	L140X	Nozzle - 2.5 mm HD CP	1
	BY310-1915CPX	3-03854, HK25	L30140X	Nozzle - 2.5 mm HD CP (10 pack)	10
	BY310-6112CP	3-06112, HK30	L265X	Nozzle - 3.0 mm HD CP	1
	BY310-6112CPX	3-06112, HK30	L30265X	Nozzle - 3.0 mm HD CP (10 pack)	10
	BY310-0035CP	HK35	L700X	Nozzle - 3.5 mm HD CP	1
	BY310-0035CPX	HK35	L30700X	Nozzle - 3.5 mm HD CP (10 pack)	10
	BY310-0040CP	HK40	L701X	Nozzle - 4.0 mm HD CP	1
	BY310-0040CPX	HK40	L30701X	Nozzle - 4.0 mm HD CP (10 pack)	10

Note: Reference number indicates nozzle style and orifice diameter(s)

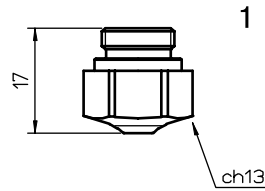

Consumables

	Centricut part number	Reference number	Alternate reference	Description	Pkg qty
	BY310-4273	3-04273, K08	L83	Nozzle - 0.8 mm	1
	BY310-4273X	3-04273, K08	L3083	Nozzle - 0.8 mm (10 pack)	10
	BY310-1905	3-01905, K10	L116	Nozzle - 1.0 mm	1
	BY310-1905X	3-01905, K10	L30116	Nozzle - 1.0 mm (10 pack)	10
	BY310-1906	3-01906, K12	L117	Nozzle - 1.25 mm	1
	BY310-1906X	3-01906, K12	L30117	Nozzle - 1.25 mm (10 pack)	10
	BY310-1907	3-01907, K15	L118	Nozzle - 1.5 mm	1
	BY310-1907X	3-01907, K15	L30118	Nozzle - 1.5 mm (10 pack)	10
	BY310-1908	3-01908, K17	L119	Nozzle - 1.75 mm	1
	BY310-1908X	3-01908, K17	L30119	Nozzle - 1.75 mm (10 pack)	10
	BY310-1909	3-01909, K20	L120	Nozzle - 2.0 mm	1
	BY310-1909X	3-01909, K20	L30120	Nozzle - 2.0 mm (10 pack)	10
	BY310-4274	3-04274, K25	L675	Nozzle - 2.5 mm	1
	BY310-4274X	3-04274, K25	L30675	Nozzle - 2.5 mm (10 pack)	10
	BY310-4275	3-04275, K30	L678	Nozzle - 3.0 mm	1
	BY310-4275X	3-04275, K30	L30678	Nozzle - 3.0 mm (10 pack)	10
1	BY310-4273CP	3-04273, K08	L83X	Nozzle - 0.8 mm CP	1
	BY310-4273CPX	3-04273, K08	L3083X	Nozzle - 0.8 mm CP (10 pack)	10
	BY310-1905CP	3-01905, K10	L116X	Nozzle - 1.0 mm CP	1
	BY310-1905CPX	3-01905, K10	L30116X	Nozzle - 1.0 mm CP (10 pack)	10
	BY310-1906CP	3-01906, K12	L117X	Nozzle - 1.25 mm CP	1
	BY310-1906CPX	3-01906, K12	L30117X	Nozzle - 1.25 mm CP (10 pack)	10
	BY310-1907CP	3-01907, K15	L118X	Nozzle - 1.5 mm CP	1
	BY310-1907CPX	3-01907, K15	L30118X	Nozzle - 1.5 mm CP (10 pack)	10
	BY310-1908CP	3-01908, K17	L119X	Nozzle - 1.75 mm CP	1
	BY310-1908CPX	3-01908, K17	L30119X	Nozzle - 1.75 mm CP (10 pack)	10
	BY310-1909CP	3-01909, K20	L120X	Nozzle - 2.0 mm CP	1
	BY310-1909CPX	3-01909, K20	L30120X	Nozzle - 2.0 mm CP (10 pack)	10
	BY310-4274CP	3-04274, K25	L675X	Nozzle - 2.5 mm CP	1
	BY310-4274CPX	3-04274, K25	L30675X	Nozzle - 2.5 mm CP (10 pack)	10
	BY310-2475CP	3-04275, K30	L678X	Nozzle - 3.0 mm CP	1
	BY310-2475CPX	3-04275, K30	L30678X	Nozzle - 3.0 mm CP (10 pack)	10

Note: Reference number indicates nozzle style and orifice diameter(s)

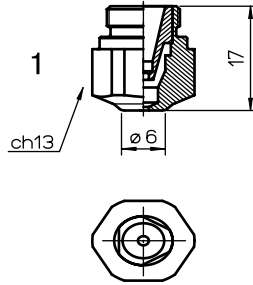

Consumables

	Centricut part number	Reference number	Alternate reference	Description	Pkg qty
	BY310-6058	3-16058, NK10-15	L1363	Nozzle - 1.0 mm double	1
	BY310-6058X	3-16058, NK10-15	L301363	Nozzle - 1.0 mm double (10 pack)	10
	BY310-6059	3-16059, NK12-15	L1364	Nozzle - 1.25 mm double	1
	BY310-6059X	3-16059, NK12-15	L301364	Nozzle - 1.25 mm double (10 pack)	10
	BY310-6060	3-16060, NK15-15	L1365	Nozzle - 1.5 mm double	1
	BY310-6060X	3-16060, NK15-15	L301365	Nozzle - 1.5 mm double (10 pack)	10
	BY310-4317	3-14317, NK17-15	L1366	Nozzle - 1.75 mm double	1
	BY310-4317X	3-14317, NK17-15	L301366	Nozzle - 1.75 mm double (10 pack)	10
	BY310-0005	3-14318, NK20-15	L604	Nozzle - 2.0 mm double	1
	BY310-0005X	3-14318, NK20-15	L30604	Nozzle - 2.0 mm double (10 pack)	10
	BY310-0006	3-14319, NK25-15	L605	Nozzle - 2.5 mm double	1
	BY310-0006X	3-14319, NK25-15	L30605	Nozzle - 2.5 mm double (10 pack)	10
	BY310-6256	3-16256, NK25-20	L612	Nozzle - 2.5 mm double	1
	BY310-6256X	3-16256, NK25-20	L30612	Nozzle - 2.5 mm double (10 pack)	10
	BY310-6061	3-16061, NK30-17	L613	Nozzle - 3.0 mm double	1
	BY310-6061X	3-16061, NK30-17	L30613	Nozzle - 3.0 mm double (10 pack)	10
	BY310-0007	3-16257, NK30-20	L606	Nozzle - 3.0 mm double	1
	BY310-0007X	3-16257, NK30-20	L30606	Nozzle - 3.0 mm double (10 pack)	10
	BY310-3530	NK35-30	L607	Nozzle - 3.5 mm double	1
	BY310-3530X	NK35-30	L30607	Nozzle - 3.5 mm double (10 pack)	10
1	BY310-6058CP	3-16058, NK10-15	L1363X	Nozzle - 1.0 mm double CP	1
	BY310-6058CPX	3-16058, NK10-15	L301363X	Nozzle - 1.0 mm double CP (10 pack)	10
	BY310-6059CP	3-16059, NK12-15	L1364X	Nozzle - 1.25 mm double CP	1
	BY310-6059CPX	3-16059, NK12-15	L301364X	Nozzle - 1.25 mm double CP (10 pack)	10
	BY310-6060CP	3-16060, NK15-15	L1365X	Nozzle - 1.5 mm double CP	1
	BY310-6060CPX	3-16060, NK15-15	L301365X	Nozzle - 1.5 mm double CP (10 pack)	10
	BY310-4317CP	3-14317, NK17-15	L1366X	Nozzle - 1.75 mm double CP	1
	BY310-4317CPX	3-14317, NK17-15	L301366X	Nozzle - 1.75 mm double CP (10 pack)	10
	BY310-0005CP	3-14318, NK20-15	L604X	Nozzle - 2.0 mm double CP	1
	BY310-0005CPX	3-14318, NK20-15	L30604X	Nozzle - 2.0 mm double CP (10 pack)	10
	BY310-0006CP	3-14319, NK25-15	L605X	Nozzle - 2.5 mm double CP	1
	BY310-0006CPX	3-14319, NK25-15	L30605X	Nozzle - 2.5 mm double CP (10 pack)	10
	BY310-6256CP	3-16256, NK25-20	L612X	Nozzle - 2.5 mm double CP	1
	BY310-6256CPX	3-16256, NK25-20	L30612X	Nozzle - 2.5 mm double CP (10 pack)	10
	BY310-6061CP	3-16061, NK30-17	L613X	Nozzle - 3.0 mm double CP	1
	BY310-6061CPX	3-16061, NK30-17	L30613X	Nozzle - 3.0 mm double CP (10 pack)	10
	BY310-0007CP	3-16257, NK30-20	L606X	Nozzle - 3.0 mm double CP	1
	BY310-0007CPX	3-16257, NK30-20	L30606X	Nozzle - 3.0 mm double CP (10 pack)	10
	BY310-3530CP	NK35-30	L607X	Nozzle - 3.5 mm double CP	1
	BY310-3530CPX	NK35-30	L30607X	Nozzle - 3.5 mm double CP (10 pack)	10

Note: Reference number indicates nozzle style and orifice diameter(s)

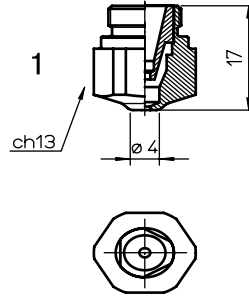
Consumables

	Centricut part number	Reference number	Alternate reference	Description	Pkg qty
1	BY310-0001	3-16058, NK10-15	L600	Nozzle - 1.0 mm double	1
	BY310-0001X	3-16058, NK10-15	L30600	Nozzle - 1.0 mm double (10 pack)	10
	BY310-0002	3-16059, NK12-15	L601	Nozzle - 1.25 mm double	1
	BY310-0002X	3-16059, NK12-15	L30601	Nozzle - 1.25 mm double (10 pack)	10
	BY310-0003	3-16060, NK15-15	L602	Nozzle - 1.5 mm double	1
	BY310-0003X	3-16060, NK15-15	L30602	Nozzle - 1.5 mm double (10 pack)	10
	BY310-0004	3-14317, NK17-15	L603	Nozzle - 1.75 mm double	1
	BY310-0004X	3-14317, NK17-15	L30603	Nozzle - 1.75 mm double (10 pack)	10
	BY310-0001CP	3-16058, NK10-15	L600X	Nozzle - 1.0 mm double CP	1
	BY310-0001CPX	3-16058, NK10-15	L30600X	Nozzle - 1.0 mm double CP (10 pack)	10
	BY310-0002CP	3-16059, NK12-15	L601X	Nozzle - 1.25 mm double CP	1
	BY310-0002CPX	3-16059, NK12-15	L30601X	Nozzle - 1.25 mm double CP (10 pack)	10
	BY310-0003CP	3-16060, NK15-15	L602X	Nozzle - 1.5 mm double CP	1
	BY310-0003CPX	3-16060, NK15-15	L30602X	Nozzle - 1.5 mm double CP (10 pack)	10
	BY310-0004CP	3-14317, NK17-15	L603X	Nozzle - 1.75 mm double CP	1
	BY310-0004CPX	3-14317, NK17-15	L30603X	Nozzle - 1.75 mm double CP (10 pack)	10

Note: Reference number indicates nozzle style and orifice diameter(s)

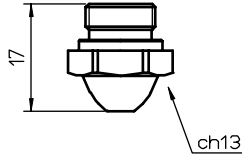

Byspeed

Consumables

	Centricut part number	Reference number	Alternate reference	Description	Pkg qty
	BY319-4271	3-04271, 08	L82	Nozzle - 0.8 mm	1
	BY319-4271X	3-04271, 08	L3082	Nozzle - 0.8 mm (10 pack)	10
	BY319-1894	3-01894, 10	L98	Nozzle - 1.0 mm	1
	BY319-1894X	3-01894, 10	L3098	Nozzle - 1.0 mm (10 pack)	10
	BY319-1895	3-01895, 12	L99	Nozzle - 1.25 mm	1
	BY319-1895X	3-01895, 12	L3099	Nozzle - 1.25 mm (10 pack)	10
	BY319-1896	3-01896, 15	L100	Nozzle - 1.5 mm	1
	BY319-1896X	3-01896, 15	L30100	Nozzle - 1.5 mm (10 pack)	10
	BY319-0897	3-01897, 17	L101	Nozzle - 1.75 mm	1
	BY319-1897	3-01897, 17	L30101	Nozzle - 1.75 mm (10 pack)	10
	BY319-1898	3-01898, 20	L102	Nozzle - 2.0 mm	1
	BY319-1898X	3-01898, 20	L30102	Nozzle - 2.0 mm (10 pack)	10
	BY319-4272	3-04272, 25	L676	Nozzle - 2.5 mm	1
	BY319-4272X	3-04272, 25	L30676	Nozzle - 2.5 mm (10 pack)	10
	BY319-4275	3-04275, H08	L673	Nozzle - 0.8 mm HD	1
	BY319-4275X	3-04275, H08	L30673	Nozzle - 0.8 mm HD (10 pack)	10
	BY319-1899	3-01899, H10	L88	Nozzle - 1.0 mm HD	1
	BY319-1899X	3-01899, H10	L3088	Nozzle - 1.0 mm HD (10 pack)	10
	BY319-1900	3-01900, H12	L103	Nozzle - 1.25 mm HD	1
	BY319-1900X	3-01900, H12	L30103	Nozzle - 1.25 mm HD (10 pack)	10
	BY319-1901	3-01901, H15	L104	Nozzle - 1.5 mm HD	1
1	BY319-1901X	3-01901, H15	L30104	Nozzle - 1.5 mm HD (10 pack)	10
	BY319-1902	3-01902, H17	L105	Nozzle - 1.75 mm HD	1
	BY319-1902X	3-01902, H17	L30105	Nozzle - 1.75 mm HD (10 pack)	10
	BY319-1903	3-01903, H20	L106	Nozzle - 2.0 mm HD	1
	BY319-1903X	3-01903, H20	L30106	Nozzle - 2.0 mm HD (10 pack)	10
	BY319-4276	3-04276, H25	L677	Nozzle - 2.5 mm HD	1
	BY319-4276X	3-04276, H25	L30677	Nozzle - 2.5 mm HD (10 pack)	10
	BY319-0030	H30	L679	Nozzle - 3.0 mm HD	1
	BY319-0030X	H30	L30679	Nozzle - 3.0 mm HD (10 pack)	10
	BY319-1899CP	3-01899, H10	L88X	Nozzle - 1.0 mm HD CP	1
	BY319-1899CPX	3-01899, H10	L3088X	Nozzle - 1.0 mm HD CP (10 pack)	10
	BY319-0900CP	3-01900, H12	L103X	Nozzle - 1.25 mm HD CP	1
	BY319-0900CPX	3-01900, H12	L30103X	Nozzle - 1.25 mm HD CP (10 pack)	10
	BY319-1901CP	3-01901, H15	L104X	Nozzle - 1.5 mm HD CP	1
	BY319-1901CPX	3-01901, H15	L30104X	Nozzle - 1.5 mm HD CP (10 pack)	10
	BY319-1902CP	3-01902, H17	L105X	Nozzle - 1.75 mm HD CP	1
	BY319-1902CPX	3-01902, H17	L30105X	Nozzle - 1.75 mm HD CP (10 pack)	10
	BY319-1903CP	3-01903, H20	L106X	Nozzle - 2.0 mm HD CP	1
	BY319-1903CPX	3-01903, H20	L30106X	Nozzle - 2.0 mm HD CP (10 pack)	10
	BY319-4276CP	3-04276, H25	L677X	Nozzle - 2.5 mm HD CP	1
	BY319-4276CPX	3-04276, H25	L30677X	Nozzle - 2.5 mm HD CP (10 pack)	10
	BY319-0030CP	H30	L679X	Nozzle - 3.0 mm HD CP	1
	BY319-0030CPX	H30	L30679X	Nozzle - 3.0 mm HD CP (10 pack)	10

Note: Reference number indicates nozzle style and orifice diameter(s)

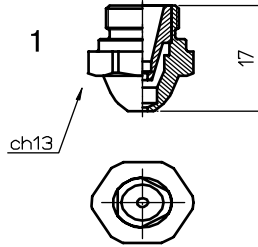

Consumables

	Centricut part number	Reference number	Alternate reference	Description	Pkg qty
1	BY319-1015	N10-15	L1250	Nozzle - 1.0 mm double	1
	BY319-1015X	N10-15	L301250	Nozzle - 1.0 mm double (10 pack)	10
	BY319-1215	N12-15	L1251	Nozzle - 1.25 mm double	1
	BY319-1215X	N12-15	L301251	Nozzle - 1.25 mm double (10 pack)	10
	BY319-1515	N15-15	L1252	Nozzle - 1.5 mm double	1
	BY319-1515X	N15-15	L301252	Nozzle - 1.5 mm double (10 pack)	10
	BY319-1715	N17-15	L1253	Nozzle - 1.75 mm double	1
	BY319-1715X	N17-15	L301253	Nozzle - 1.75 mm double (10 pack)	10
	BY319-2015	N20-15	L1254	Nozzle - 2.0 mm double	1
	BY319-2015X	N20-15	L301254	Nozzle - 2.0 mm double (10 pack)	10
	BY319-2515	N25-15	L1255	Nozzle - 2.5 mm double	1
	BY319-2515X	N25-15	L301255	Nozzle - 2.5 mm double (10 pack)	10
	BY319-2520	N25-20	L1256	Nozzle - 2.5 mm double	1
	BY319-2520X	N25-20	L301256	Nozzle - 2.5 mm double (10 pack)	10
	BY319-3017	N30-17	L1257	Nozzle - 3.0 mm double	1
	BY319-3017X	N30-17	L301257	Nozzle - 3.0 mm double (10 pack)	10
	BY319-3020	N30-20	L1258	Nozzle - 3.0 mm double	1
	BY319-3020X	N30-20	L301258	Nozzle - 3.0 mm double (10 pack)	10
	BY319-1015CP	N10-15	L1250X	Nozzle - 1.0 mm double CP	1
	BY319-1015CPX	N10-15	L301250X	Nozzle - 1.0 mm double CP (10 pack)	10
	BY319-1215CP	N12-15	L1251X	Nozzle - 1.25 mm double CP	1
	BY319-1215CPX	N12-15	L301251X	Nozzle - 1.25 mm double CP (10 pack)	10
	BY319-1515CP	N15-15	L1252X	Nozzle - 1.5 mm double CP	1
	BY319-1515CPX	N15-15	L301252X	Nozzle - 1.5 mm double CP (10 pack)	10
	BY319-1715CP	N17-15	L1253X	Nozzle - 1.75 mm double CP	1
	BY319-1715CPX	N17-15	L301253X	Nozzle - 1.75 mm double CP (10 pack)	10
	BY319-2015CP	N20-15	L1254X	Nozzle - 2.0 mm double CP	1
	BY319-2015CPX	N20-15	L301254X	Nozzle - 2.0 mm double CP (10 pack)	10
	BY319-2515CP	N25-15	L1255X	Nozzle - 2.5 mm double CP	1
	BY319-2515CPX	N25-15	L301255X	Nozzle - 2.5 mm double CP (10 pack)	10
	BY319-2520CP	N25-20	L1256X	Nozzle - 2.5 mm double CP	1
	BY319-2520CPX	N25-20	L301256X	Nozzle - 2.5 mm double CP (10 pack)	10
	BY319-3017CP	N30-17	L1257X	Nozzle - 3.0 mm double CP	1
	BY319-3017CPX	N30-17	L301257X	Nozzle - 3.0 mm double CP (10 pack)	10
	BY319-3020CP	N30-20	L1258X	Nozzle - 3.0 mm double CP	1
	BY319-3020CPX	N30-20	L301258X	Nozzle - 3.0 mm double CP (10 pack)	10

Note: Reference number indicates nozzle style and orifice diameter(s)

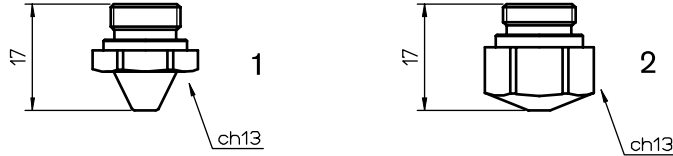

Consumables

	Centricut part number	Reference number	Alternate reference	Description	Pkg qty
1	BY318-4271	3-04271, 08	L22	Nozzle - 0.8 mm	1
	BY318-4271X	3-04271, 08	L3022	Nozzle - 0.8 mm (10 pack)	10
	BY318-1894	3-01894, 10	L14	Nozzle - 1.0 mm	1
	BY318-1894X	3-01894, 10	L3014	Nozzle - 1.0 mm (10 pack)	10
	BY318-1895	3-01895, 12	L41	Nozzle - 1.25 mm	1
	BY318-1895X	3-01895, 12	L3041	Nozzle - 1.25 mm (10 pack)	10
	BY318-1896	3-01896, 15	L17	Nozzle - 1.5 mm	1
	BY318-1896X	3-01896, 15	L3017	Nozzle - 1.5 mm (10 pack)	10
	BY318-1897	3-01897, 17	L42	Nozzle - 1.75 mm	1
	BY318-1897X	3-01897, 17	L3042	Nozzle - 1.75 mm (10 pack)	10
	BY318-1898	3-01898, 20	L33	Nozzle - 2.0 mm	1
	BY318-1898X	3-01898, 20	L3033	Nozzle - 2.0 mm (10 pack)	10
	BY318-1899	3-01899, H10	L43	Nozzle - 1.0 mm HD	1
	BY318-1899X	3-01899, H10	L3043	Nozzle - 1.0 mm HD (10 pack)	10
	BY318-1900	3-01900, H12	L16	Nozzle - 1.25 mm HD	1
	BY318-1900X	3-01900, H12	L3016	Nozzle - 1.25 mm HD (10 pack)	10
	BY318-1901	3-01901, H15	L44	Nozzle - 1.5 mm HD	1
	BY318-1901X	3-01901, H15	L3044	Nozzle - 1.5 mm HD (10 pack)	10
	BY318-1902	3-01902, H17	L45	Nozzle - 1.75 mm HD	1
	BY318-1902X	3-01902, H17	L3045	Nozzle - 1.75 mm HD (10 pack)	10
BY318-1903	3-01903, H20	L46	Nozzle - 2.0 mm HD	1	
BY318-1903X	3-01903, H20	L3046	Nozzle - 2.0 mm HD (10 pack)	10	
2	BY320-4273	3-04273, K08	L71	Nozzle - 0.8 mm	1
	BY320-4273X	3-04273, K08	L3071	Nozzle - 0.8 mm (10 pack)	10
	BY320-1905	3-01905, K10	L107	Nozzle - 1.0 mm	1
	BY320-1905X	3-01905, K10	L30107	Nozzle - 1.0 mm (10 pack)	10
	BY320-1906	3-01906, K12	L108	Nozzle - 1.25 mm	1
	BY320-1906X	3-01906, K12	L30108	Nozzle - 1.25 mm (10 pack)	10
	BY320-1907	3-01907, K15	L109	Nozzle - 1.5 mm	1
	BY320-1907X	3-01907, K15	L30109	Nozzle - 1.5 mm (10 pack)	10
	BY320-1908	3-01908, K17	L110	Nozzle - 1.75 mm	1
	BY320-1908X	3-01908, K17	L30110	Nozzle - 1.75 mm (10 pack)	10
	BY320-1909	3-01909, K20	L111	Nozzle - 2.0 mm	1
	BY320-1909X	3-01909, K20	L30111	Nozzle - 2.0 mm (10 pack)	10
	BY320-1910	3-01910, HK10	L89	Nozzle - 1.0 mm HD	1
	BY320-1910X	3-01910, HK10	L3089	Nozzle - 1.0 mm HD (10 pack)	10
	BY320-1911	3-01911, HK12	L112	Nozzle - 1.25 mm HD	1
	BY320-1911X	3-01911, HK12	L30112	Nozzle - 1.25 mm HD (10 pack)	10
	BY320-1912	3-01912, HK15	L113	Nozzle - 1.5 mm HD	1
	BY320-1912X	3-01912, HK15	L30113	Nozzle - 1.5 mm HD (10 pack)	10
	BY320-1913	3-01913, HK17	L114	Nozzle - 1.75 mm HD	1
	BY320-1913X	3-01913, HK17	L30114	Nozzle - 1.75 mm HD (10 pack)	10
BY320-1914	3-01914, HK20	L115	Nozzle - 2.0 mm HD	1	
BY320-1914X	3-01914, HK20	L30115	Nozzle - 2.0 mm HD (10 pack)	10	

Note: Reference number indicates nozzle style and orifice diameter(s)

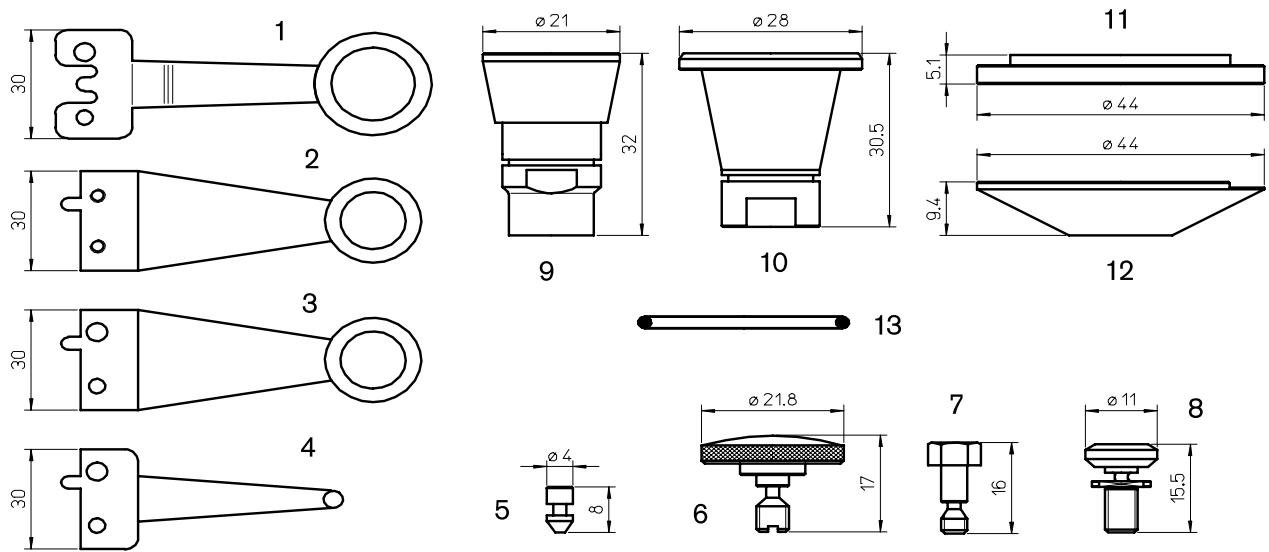
Accessories

	Centricut part number	Reference number	Alternate reference	Description	Pkg qty	
	1	BY328-5530	3-05530	AL26	Scanner	1
	2	BY328-2015	2-01262	AL5	Scanner	1
	3	BY328-0015	2-02015	AL252	Scanner	1
	4	BY328-2016	2-02016	AL251	Ball scanner	1
	5	BY328-3137	4-03137	AL24	Pin	5
	6	BY328-3136	4-03136	AL25	Knurled screw - brass	1
	7	BY328-0324	4-00324	AL1	Knurled screw	1
	8	BY328-9001	3-09001	AL208	Cross jet screw	1
	9	BY328-2291	3-02291	AL188	Nozzle body	1
	10	BY328-5497	3-05497	AL102	Nozzle body - copper	1
	11	BY328-3663-T	3-03663-T	AL206	Disc PTFE*	1
	12	BY328-3663-C	3-03663-C	AL205	Signboard ceramic	1
13	BY328-1300	3141300	AL225	O-ring	1	
	BY328-1122	3141122	AL226	O-ring	1	
	BY328-0236	3140236	3140236	O-ring	1	
	BY328-0820	3140820	AL99	O-ring for lens	1	
	BY328-0004 (not shown)		AL246	Screw kit (3 pcs) for BY328-3663-C	3	

*PolyTetraFluoroEthylene is a fluorocarbon-based polymer and is commonly abbreviated PTFE. The Teflon® brand of PTFE is manufactured only by DuPont and is not sold by Hypertherm. Hypertherm purchases other brands of PTFE from various high quality manufacturers.

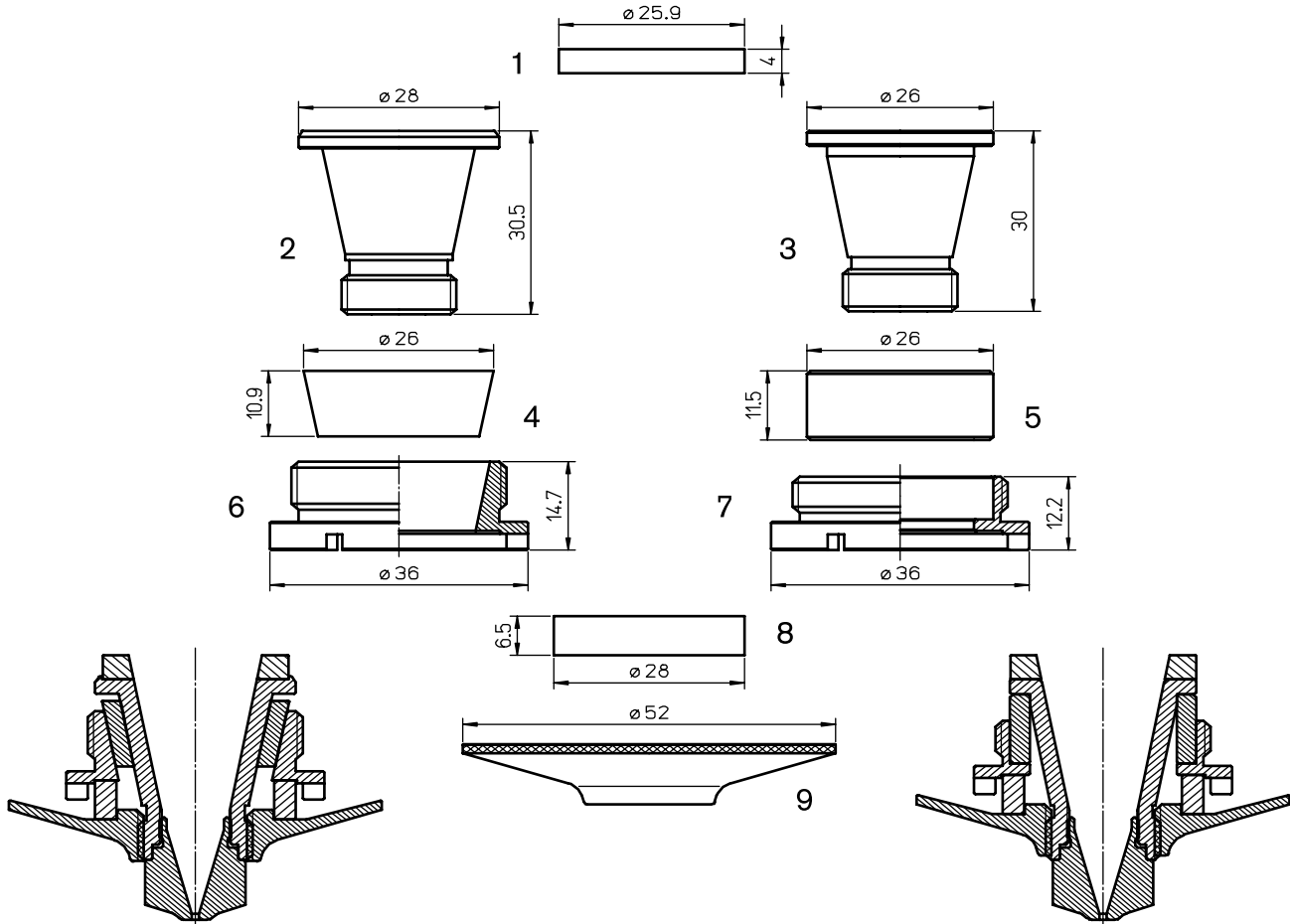

Consumables

	Centricut part number	Reference number	Alternate reference	Description	Pkg qty
1	BY328-0642	4-01642	AL125	Insulation disc - ceramic	1
	BY328-1642	4-01642	AL231	Insulation disc (new version) - ceramic	1
2	BY328-8701	2-08701	AL172	Nozzle body	1
3	BY359-2930 NEW	10032930	AL423	Nozzle body	1
4	BY328-0959	4-01959	AL124	Cone - ceramic	1
	BY328-1959	4-01959	AL230	Cone (new version) - ceramic	1
5	BY359-2838 NEW	10032838	AL425	Ceramic insulating ring	1
6	BY328-1071	3-11071	AL174	Fastening nut	1
7	BY359-2839 NEW	10032839	AL424	Fastening nut	1
8	BY328-9010	4-09010	AL126	Insulation ring - ceramic	1
9	BY328-8700	2-08700	AL173	Signboard	1
	BY328-0005	2-08700	AL173X	Signboard - CP	1

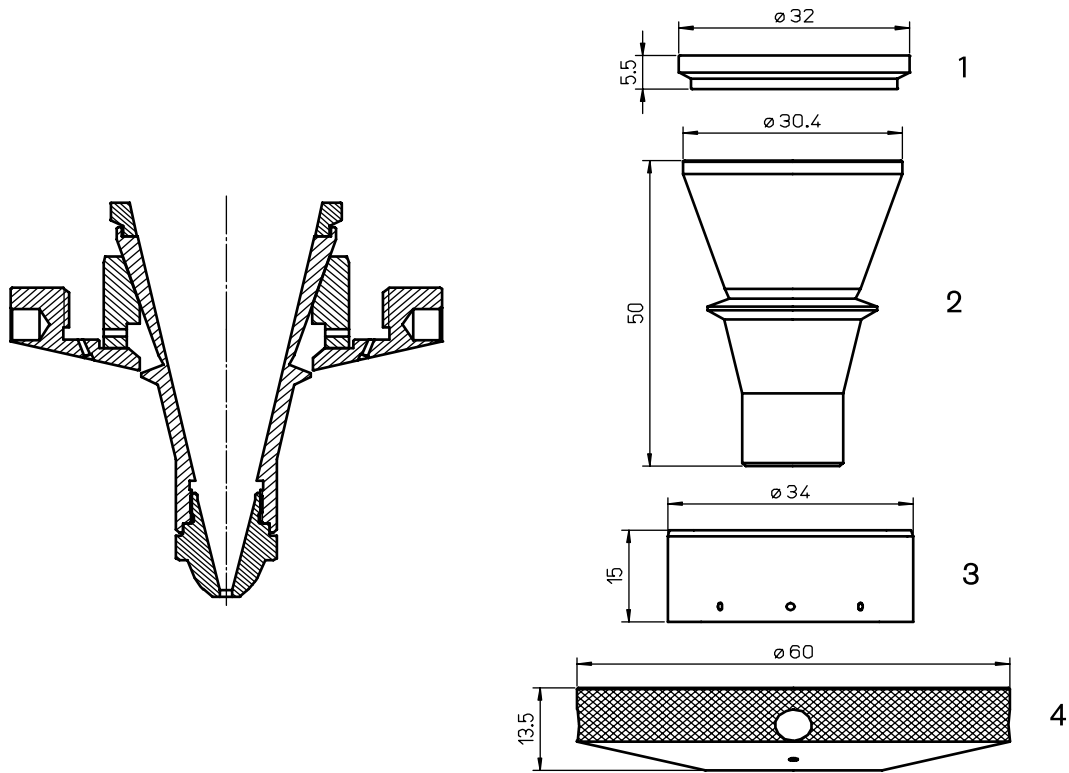

Consumables

	Centricut part number	Reference number	Alternate reference	Description	Pkg qty
1	BY359-3113	3-13113	AL215	Insulating ring	1
2	BY359-0837	2-10837	AL214	Nozzle body	1
3	BY359-3422	3-13422	AL216	Insulating ring w/holes	1
4	BY359-3110	3-13110	AL258	Shield - copper	1

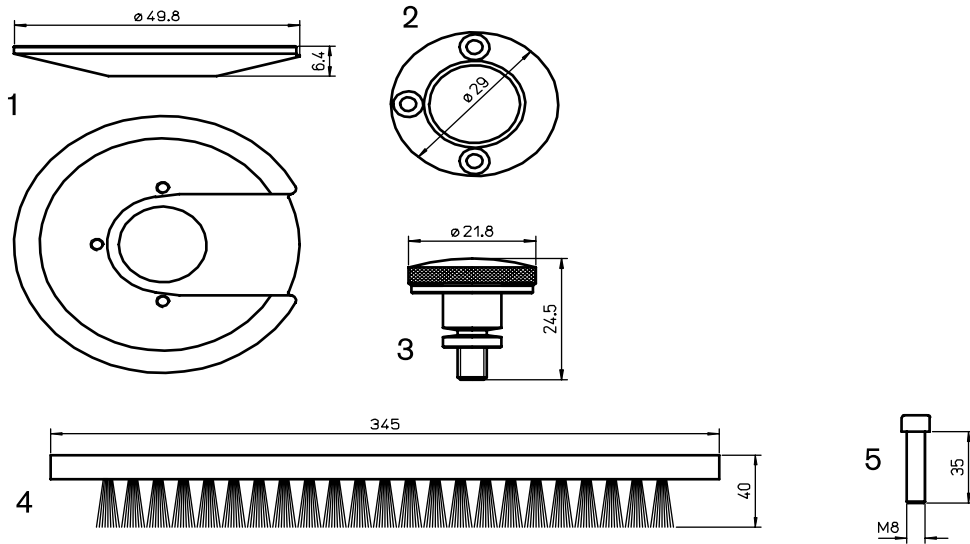
Accessories

	Centricut part number	Reference number	Alternate reference	Description	Pkg qty
1	BY359-6035	3-06035	AL222	Signboard copper only	1
	BY359-0001		AL245	Screw kit (3 pcs) for BY359-6035	3
2	BY328-328-1	3-06035-T	AL120	Disc PTFE*	1
	BY328-328-2	3-06035-P	AL120/P	Disc long life	1
3	BY328-4976	4-04976	AL209	Knurled screw	1
4	BY328-6511	2-06511	AL300	Brush w/screws	1
5	BY328-3884	333884	333884	Plastic screws (2 pcs)	2
Filters - not shown					
	BY328-0020	D020	7004621	Air filter	1
	BY328-4753	71064753	7001341	Vacuum pump filter	1
	BY328-0145	8820145	8820145	Water filter 60/MC	1
	BY328-0154	8820154	8820154	Water filter 140M/C	1
	BY328-9417	A37100MFO	7509417	Filter 37x106	1
	BY328-9412		7509412	Air filter (active coal)	1
	BY328-2456	502456	502456	Vacuum pump filter - 4000W	1

*PolyTetraFluoroEthylene is a fluorocarbon-based polymer and is commonly abbreviated PTFE. The Teflon® brand of PTFE is manufactured only by DuPont and is not sold by Hypertherm. Hypertherm purchases other brands of PTFE from various high quality manufacturers.

Optics

Centricut part number	Reference number	Type	Diameter	Focal length	Edge thickness
Lenses					
BY314-0185	4-00185	MEN	1.5"	3.75"	.236"
BY314-0736	4-10736	MEN	1.5"	3.75"	.354"
BY314-0186	4-00186	MEN	1.5"	5.00"	.236"
BY314-0187	4-00187	MEN	1.5"	7.50"	.236"
BY314-5094	4-05094	MEN	1.5"	5.00"	.354"
BY314-1644	120216, 621644	MEN	1.5"	5.00"	.354"
BY314-5095	4-05095	MEN	1.5"	7.50"	.354"
BY314-8637	698637	MEN	1.5"	7.50"	.354"
BY314-7475	4-07475	PLX	1.5"	5.00"	.354"
Ultra low absorption lenses					
BY314-0186MP5	4-00186	MEN	1.5"	5.00"	.236"
BY314-0187MP5	4-00187	MEN	1.5"	7.50"	.236"
BY314-5094MP5	4-05094	MEN	1.5"	5.00"	.354"
BY314-5095MP5	4-05095	MEN	1.5"	7.50"	.354"

Centricut part number	Reference number	Material	Diameter	Edge thickness	S1
Phase shift mirrors					
BY314-0226	4-00226	CU	1.96"	.394"	
BY314-9328	4-09328	CU	1.96"	.394"	
BY314-8232	558232/F	CU	2.0"	2.126"	

Centricut part number	Reference number	Type	Material	Diameter	Edge thickness	S1
Collimating optics						
BY314-1017	4-11017	MMR	CU	1.96"	.394"	100MCC
BY314-1018	4-11018	MMR	CU	1.96"	.394"	10MCC
BY314-7006	4-07006	MMR	CU	1.96"	.394"	2MCC/SPT
BY314-7007	4-07007	MMR	CU	1.96"	.394"	1.4MCX
BY314-9332	4-09332	MMR	CU	2.36"	.393"	45 DEG

Centricut part number	Reference number	Type	Material	Diameter	Edge thickness	S1
Zero phase shift mirrors and total reflectors						
BY314-9329	4-09329	TRZ	CU	1.96"	.394"	
BY314-5173	4-05173	TRZ	CU	1.96"	.394"	1.68MCX
BY314-5172	4-05172	TRZ	CU	2.0"	.390"	1MCX
BY314-0227	4-00227	TRZ	CU	2.0"	.390"	
BY314-9537	NEW 169537	PS	CU	1.968"	.394"	
BY314-0206	NEW 754229	ZPS	CU	1.496"	.236"	
BY314-0203	4-00203	ZPS	CU	1.96"	.394"	
BY314-0201	4-00201	ZPS	CU	2.0"	.390"	
BY314-0214	4-00214	ZPS	CU	2.0"	.390"	2.25MCX
BY314-0217	4-00217	ZPS	CU	2.0"	.390"	3MCC
BY314-0200	4-0020	ZPS	CU	2.36"	.390"	
BY314-2580	NEW 172580	MMR	CU	1.968"	.375"	2.28MCX
BY314-1030	4-11030	MMR	CU	1.96"	.394"	80MCC
BY314-1029	4-11029	MMR	CU	1.96"	.394"	80MCC/EG
BY314-1425	591425/F	MMR	CU	2.0"	2.126"	

Centricut is a registered trademark of Hypertherm Inc. and may be registered in the United States and/or other countries. All other trademarks are the properties of their respective owners. Centricut is in no way affiliated with Bystronic.

Optics

Centricut part number	Reference number	Material	Diameter	Edge thickness	S1/Reflectivity	S2
Output couplers						
BY314-3122	4-03122	ZNSE	1.0"	.236"	30MMC-65%	30MCX
BY314-9352	4-09352	ZNSE	1.18"	.236"	30MCC	
BY314-8318	4-08318	ZNSE	1.18"	.236"	30MCC-50%	
Rear mirrors						
BY314-3118	4-03118	GE	1.0"	.236"	15MCC-99.60%	
BY314-6043	NEW 816043	GE	1.1"	.220"	15MCC	0.6MCX
BY314-9336	4-09336	GE	1.18"	.236"	15MCC	
BY314-8317	4-08317	GE	1.18"	.236"	30MCC-99.60%	

Optics care

Centricut part number	Reference number	Description	Pkg qty
TR300-6452	N/A	Lens cleaning paper, Tiffen - 50 piece	1
AM313-SC50	NEW SC50	Lens cleaning paper, Tresor - 50 piece	1
TR300-1115		Lens cleaning pre-cut cotton - 80 piece	1
TR300-SC20		Cotton swab - 20 piece	1
TR300-1010	AL1010	Dropper, lens cleaning fluid	1
TR300-255	AL255	Loupe, magnifying	1
TR300-271	AL271	Base, lens maintenance	1
TR300-7388	787388	Mirror polish (250 ml)	1
AM313-1260	NEW 351260-009	Lens Polarizing Filter - 1.5"	1
AM313-1280	NEW 351280-009	Lens Polarizing Filter - 2.0"	1

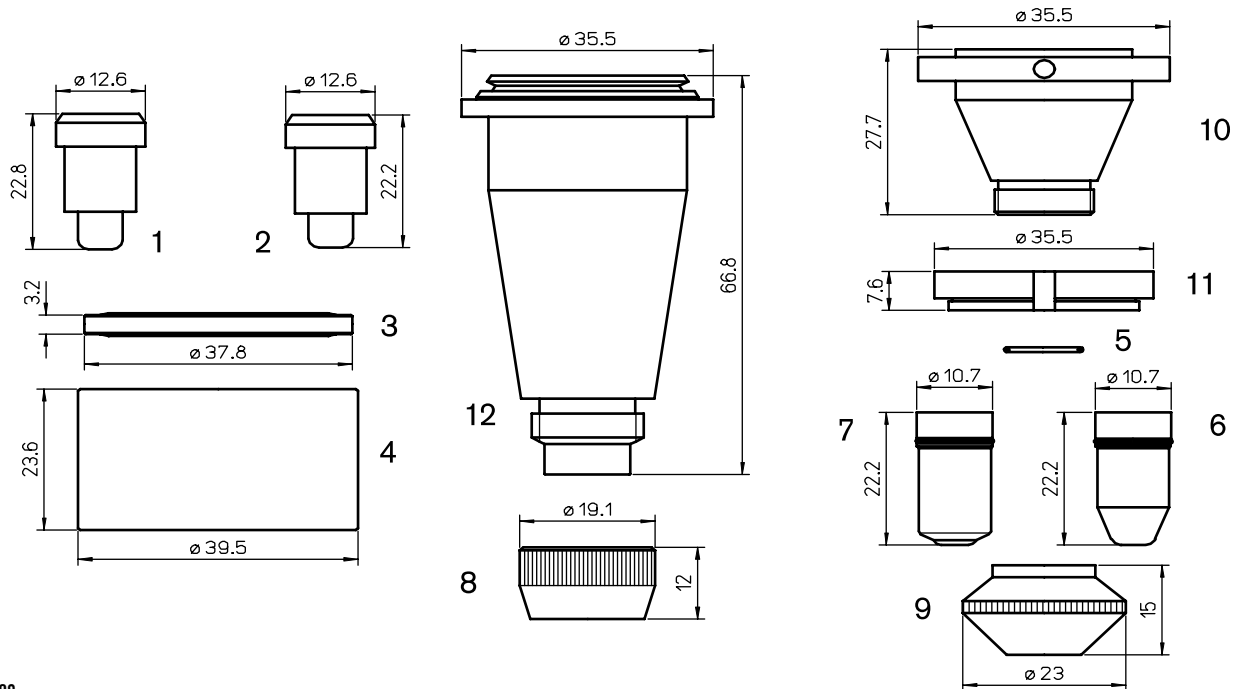

Consumables

	Centricut part number	Reference number	Alternate reference	Description	Pkg qty
1	CN305-8090	908090	L220	Elongated nozzle - 1.5 mm (0.060")	1
2	CN305-7469	907469	L221	Nozzle - 1.0 mm (0.040")	1
	CN305-7470	907470	L222	Nozzle - 1.5 mm (0.060")	1
	CN305-0006	920006	L223	Nozzle - 2.0 mm (0.080")	1
3	CN305-0000		AL92	Gasket - PTFE* w/spring	1
4	CN305-7677	907677	AL71/S	Nozzle holder - contact	1
	CN305-7472	907472	AL71	Nozzle holder - contact w/gasket	1
5	CN306-9680	909680	AL95	O-ring for nozzle	10
6	CN306-0011		L1528	Nozzle - 0.8 mm (.0315")	1
	CN306-9660-1	924635	L712	Nozzle - 1.0 mm (0.040")	1
	CN306-0012		L961	Nozzle - 1.2 mm (0.045")	1
	CN306-0013		L962	Nozzle - 1.3 mm (0.050")	1
	CN306-0014		L963	Nozzle - 1.4 mm (0.055")	1
	CN306-9660	909660	L224	Nozzle - 1.5 mm (0.060")	1
	CN306-0315	910315	L225	Nozzle - 2.0 mm (0.080")	1
	CN306-3789	924638	L713	Nozzle - 2.5 mm (0.100")	1
	CN306-4634	924634	L714	Nozzle - 3.0 mm (0.120")	1
	CN306-4635	924635	L1017	Nozzle - 3.15 mm (.124")	1
	CN306-3013	923013	L433	Nozzle - 1.0 mm shower (0.040")	1
	CN306-3014	923014	L434	Nozzle - 1.5 mm shower (0.060")	1
	CN306-0020		L435	Nozzle - 2.0 mm shower (0.080")	1
7	CN306-4636	924636	L869	Nozzle - 1.5 mm (0.060")	1
	CN306-4637	924637	L870	Nozzle - 2.0 mm (0.080")	1
8	CN306-9659	909659	AL48	Tip lock nut	1
9	CN306-3021	963021	AL135	Tip retainer nut	1
10	CN306-0150	923258	AL137	Nozzle body	1
11	CN306-0001	923259	AL139	Insulator ring	1
12	CN306-9658	909658	AL183	Tip retainer extension	1
	CN306-9664 (not shown)	909664, 56161		O-ring	1
	CN306-0654A (not shown)	909654, 922686		Sensor cable - armored 114 mm (4.5")	1
	CN306-0951A (not shown)	842951		Sensor cable - armored 140 mm (5.5")	1
	CN306-9654 (not shown)	909654, 922686		Sensor cable 114 mm (4.5")	1
	CN306-2951 (not shown)	842951		Sensor cable 140 mm (5.5")	1

*PolyTetraFluoroEthylene is a fluorocarbon-based polymer and is commonly abbreviated PTFE. The Teflon® brand of PTFE is manufactured only by DuPont and is not sold by Hypertherm. Hypertherm purchases other brands of PTFE from various high quality manufacturers.

Centricut is a registered trademark of Hypertherm Inc. and may be registered in the United States and/or other countries. All other trademarks are the properties of their respective owners. Centricut is in no way affiliated with Cincinnati.

Optics

Centricut part number	Reference number	Type	Diameter	Focal length	Edge thickness
Lenses					
CN307-7557	907557	PLX	1.5"	5.0"	.160"
CN307-8085	908085	PLX	1.5"	5.0"WD	.280"
CN307-9484	909484	PLX	1.5"	7.5"WD	.280"
CN307-0676	922377	PLX	2.0"	5.0"WD	.380"
CN307-1603	922376	PLX	2.0"	7.5"WD	.380"
CN307-4498	154498	PLX	2.0"	10.0"WD	.380"
CN307-2377	922377	PLX	2.0"	5.0"	.380"
CN307-2376	922376	PLX	2.0"	7.5"	.380"
CN307-2722	922722	PLX	2.0"	4M	.236"
Ultra low absorption lenses					
CN307-8085NUL	908085	PLX	1.5"	5.0"WD	.280"
CN307-9484NUL	909484	PLX	1.5"	7.5"WD	.280"
CN307-2377NUL	922377	PLX	2.0"	5.0"	.380"
CN307-0211NUL	504211	PLX	2.0"	5.0"WD	.380"
CN307-2376NUL	922376	PLX	2.0"	7.5"	.380"

Centricut part number	Reference number	Type	Diameter	Edge thickness	S1
Collimating optics					
CN307-0296	920296	OUTPUT	1.97"	.375"	2.44MCC
CN307-0295	920295	INPUT	1.97"	.375"	1.73MCX

Centricut part number	Reference number	Material	Diameter	Edge thickness	S1
Phase shift mirrors					
CN307-8237	498237	SI	1.5"	.160"	
CN307-5214	845214	CU	1.96"	.375"	
CN307-5587	335587	SI	2.0"	.200"	
CN307-9975	909975	CU	2.25"	.390"	
CN307-2768	922768	CU	2.25"	1.25"	WC
CN307-2515	922515	CU	2.5"	.390"	

Centricut part number	Reference number	Material	Diameter	Edge thickness	Reflectivity
Absorbing thin film reflectors (ATFR)					
CN307-3414	923414	CU	2.0"	.375"	99.50%

Centricut part number	Reference number	Type	Material	Diameter	Edge thickness	S1
Zero phase shift mirrors and total reflectors						
CN307-7753	957753/F	TRZ	CU	1.96"	1.0"	
CN307-3849	233849	TRZ	CU	1.96"	.375"	
CN307-1793	909772	TRZ	CU	1.5"	.236"	
CN307-9772	909772	TRZ	CU	2.0"	2.126"	PLANO WC
CN307-2645	922645	MMR	SI	2.0"	.200"	PLANO
CN307-2992	222992	TRZ	SI	2.0"	.200"	45D
CN307-7971	907971	TRZ	SI	2.0"	.200"	
CN307-9976	909976	ZPS	CU	2.25"	.390"	
CN307-2769	922769	ZPS	CU	2.25"	1.25"	WC
CN307-0341	910341	ZPS	CU	3.0"	.500"	
CN307-3010	923010	TRZ	CU	3.0"	.500"	

Centricut part number	Reference number	Material	Diameter	Edge thickness	S1/Reflectivity	S2
Output couplers						
CN307-7969	907969	ZNSE	1.0"	.236"	30MCC-65%	30MCX
CN307-4510	924510	ZNSE	1.5"	.315"	15MCC-40%	
CN307-3604	923604	ZNSE	1.5"	.315"	40MCC-50%	
CN307-2668	922668	ZNSE	1.5"	.315"	51.6MCC-50%	25MCX
Rear mirrors						
CN307-7970	907970	GE	1.0"	0.236"	15MCC-99.5%	PO/AR
CN307-4511	924511	GE	1.5"	.315"	15MCC-99.5%	PO/AR
CN307-3603	6923603	GE	1.5"	.315"	40MCC-99.5%	PO
CN307-2644	922644	GE	1.5"	.315"	51.6MCC-99.5%	PO/AR

Optics care

Centricut part number	Reference number	Description	Pkg qty
TR300-6452	N/A	Lens cleaning paper, Tiffen - 50 piece	1
AM313-SC50	SC50	Lens cleaning paper, Tresor - 50 piece	1
TR300-1115		Lens cleaning pre-cut cotton - 80 piece	1
TR300-SC20		Cotton swab - 20 piece	1
TR300-1010	AL1010	Dropper, lens cleaning fluid	1
TR300-255	AL255	Loupe, magnifying	1
TR300-271	AL271	Base, lens maintenance	1
TR300-7388	787388	Mirror polish (250 ml)	1
AM313-1260	351260-009	Lens Polarizing Filter - 1.5"	1
AM313-1280	351280-009	Lens Polarizing Filter - 2.0"	1

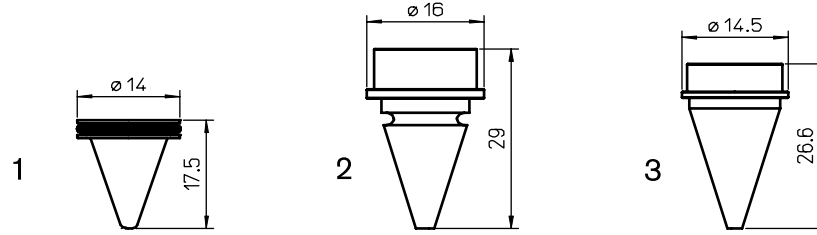
Consumables

	Centricut part number	Reference number	Alternate reference	Description	Pkg qty
1	TR414-0008	12-11-16-00	L507	Nozzle - 0.8 mm YAG w/o-ring	1
	TR414-0010		L506	Nozzle - 1.0 mm YAG w/o-ring	1
	TR414-0012	12-11-09-17/00	L505	Nozzle - 1.2 mm YAG w/o-ring	1
2	HS392-0001		L476	Nozzle - 0.6 mm	1
	HS392-0002		L477	Nozzle - 0.8 mm	1
	HS392-0003		L478	Nozzle - 1.0 mm	1
3	HS392-0004		L509	Nozzle - 0.9 mm	1

Optics care

Centricut part number	Reference number	Description	Pkg qty
TR300-6452	N/A	Lens cleaning paper, Tiffen - 50 piece	1
AM313-SC50 NEW	SC50	Lens cleaning paper, Tresor - 50 piece	1
TR300-1115		Lens cleaning pre-cut cotton - 80 piece	1
TR300-SC20		Cotton swab - 20 piece	1
TR300-1010	AL1010	Dropper, lens cleaning fluid	1
TR300-255	AL255	Loupe, magnifying	1
TR300-271	AL271	Base, lens maintenance	1
TR300-7388	787388	Mirror polish (250 ml)	1
AM313-1260 NEW	351260-009	Lens Polarizing Filter - 1.5"	1
AM313-1280 NEW	351280-009	Lens Polarizing Filter - 2.0"	1

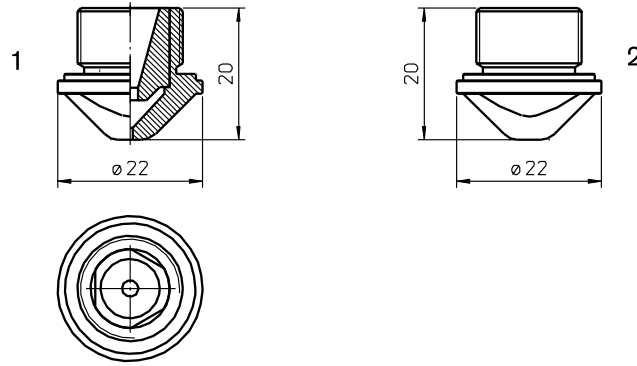
Consumables

	Centricut part number	Reference number	Alternate reference	Description	Pkg qty
1	HA392-0001		L525	Nozzle - 2.5 mm double	1
2	HA392-0002		L526	Nozzle - 1.0 mm	1
	HA392-0003		L533	Nozzle - 1.2 mm	1
	HA392-0004		L527	Nozzle - 1.5 mm	1
	HA392-0005		L528	Nozzle - 1.7 mm	1
	HA392-0006		L529	Nozzle - 2.0 mm	1
	HA392-0007		L530	Nozzle - 2.5 mm	1
	HA392-0008		L531	Nozzle - 3.0 mm	1

Optics

Centricut part number	Reference number	Type	Material	Diameter	Edge thickness	
Zero phase shift mirrors and total reflectors						
HA425-6101	NEW 816101/F	MMR	CU	2.36"	.984"	8

Centricut part number	Reference number	Type	Material	Diameter	Edge thickness	
Phase shift mirrors						
HA425-6392	NEW 886392/F	PS	CU	2.36"	.984"	8

Optics care

Centricut part number	Reference number	Description	Pkg qty
TR300-6452	N/A	Lens cleaning paper, Tiffen - 50 piece	1
AM313-SC50	NEW SC50	Lens cleaning paper, Tresor - 50 piece	1
TR300-1115		Lens cleaning pre-cut cotton - 80 piece	1
TR300-SC20		Cotton swab - 20 piece	1
TR300-1010	AL1010	Dropper, lens cleaning fluid	1
TR300-255	AL255	Loupe, magnifying	1
TR300-271	AL271	Base, lens maintenance	1
TR300-7388	787388	Mirror polish (250 ml)	1
AM313-1260	NEW 351260-009	Lens Polarizing Filter - 1.5"	1
AM313-1280	NEW 351280-009	Lens Polarizing Filter - 2.0"	1

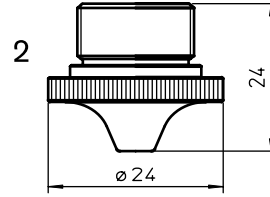
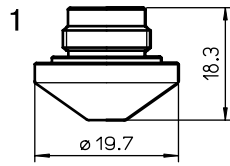

Consumables

	Centricut part number	Reference number	Alternate reference	Description	Pkg qty
1	HW405-1010	NP10	L1070	Nozzle - 1.0 mm	1
	HW405-1012	NP12	L1071	Nozzle - 1.2 mm	1
	HW405-1015	NP15	L1072	Nozzle - 1.5 mm	1
	HW405-1017	NP17	L1073	Nozzle - 1.7 mm	1
	HW405-1020	NP20	L1074	Nozzle - 2.0 mm	1
	HW405-1025	NP25	L1075	Nozzle - 2.5 mm	1
	HW405-1030	NP30	L1076	Nozzle - 3.0 mm	1
2	HW405-3010	NP10	L1490	Nozzle - 1.0 mm	1
	HW405-3012	NP12	L1491	Nozzle - 1.2 mm	1
	HW405-3015	NP15	L1492	Nozzle - 1.5 mm	1
	HW405-3025 NEW	NP15	L1494	Nozzle - 2.5 mm	1

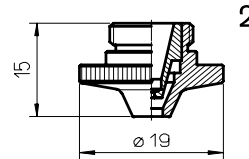
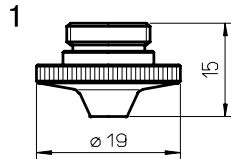

Consumables

	Centricut part number	Reference number	Alternate reference	Description	Pkg qty
1	HW405-2008	NP08	L1482	Nozzle - 0.8 mm	1
	HW405-2010	NP10, MX-0860	L1483	Nozzle - 1.0 mm	1
	HW405-2012	NP12, MX-0861	L1484	Nozzle - 1.2 mm	1
	HW405-2015	NP15, MX0862	L1485	Nozzle - 1.5 mm	1
	HW405-2020	NP20, MX-0864	L1486	Nozzle - 2.0 mm	1
	HW405-2018	NP18, MX-0863	L1487	Nozzle - 1.8 mm	1
	HW405-2025	NP25, MX-0865	L1488	Nozzle - 2.5 mm	1
HW405-2030	NP30, MX-0866	L1489	Nozzle - 3.0 mm	1	
2	HW405-4010	TP10	L1521	Nozzle - 1.0 mm double	1
	HW405-4015 NEW	TP15	L1522	Nozzle - 1.5 mm double	1
	HW405-4020 NEW	TP20	L1523	Nozzle - 2.0 mm double	1
	HW405-4025 NEW	TP25	L1524	Nozzle - 2.5 mm double	1
	HW405-4030 NEW	TP30	L1526	Nozzle - 3.0 mm double	1
	HW405-4040	TP40	L1525	Nozzle - 4.0 mm double	1

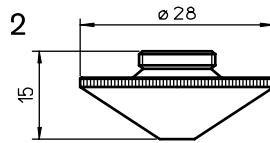
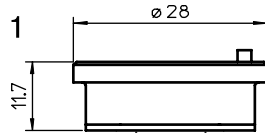

Consumables

	Centricut part number	Reference number	Alternate reference	Description	Pkg qty
1	HW405-0811		AL408	Nozzle holder - ceramic	1
2	PT345-0008		L935	Nozzle - 0.8 mm HD	1
	PT345-1548	281548, P0591-571-00010	L234	Nozzle - 1.0 mm HD	1
	PT345-1549	281549, P0591-572-00012	L235	Nozzle - 1.2 mm HD	1
	PT345-1463	281463, P0591-573-00015	L236	Nozzle - 1.5 mm HD	1
	PT345-0001	P0591-574-00018	L237	Nozzle - 1.8 mm HD	1
	PT345-1550	281550, P0591-575-00020	L238	Nozzle - 2.0 mm HD	1
	PT345-0003		L239	Nozzle - 2.3 mm HD	1
	PT345-1551	281551, P0591-576-00025	L240	Nozzle - 2.5 mm HD	1
	PT345-1552		L936	Nozzle - 2.75 mm HD	1
	PT345-0002		L241	Nozzle - 3.0 mm HD	1
	PT345-0005		L826	Nozzle - 3.2 mm HD	1
	PT345-0006		L827	Nozzle - 3.5 mm HD	1
	PT345-0004		L828	Nozzle - 4.0 mm HD	1
	PT345-0007		L829	Nozzle - 4.5 mm HD	1
	PT345-1547CP		L935X	Nozzle - 0.8 mm HD CP	1
	PT345-1548CP	281548, P0591-571-00010	L234X	Nozzle - 1.0 mm HD CP	1
	PT345-1549CP	281549, P0591-572-00012	L235X	Nozzle - 1.2 mm HD CP	1
	PT345-1463CP	281463, P0591-573-00015	L236X	Nozzle - 1.5 mm HD CP	1
	PT345-0001CP		L237X	Nozzle - 1.8 mm HD CP	1
	PT345-1550CP	281550, P0591-575-00020	L238X	Nozzle - 2.0 mm HD CP	1
	PT345-0003CP		L239X	Nozzle - 2.3 mm HD CP	1
	PT345-1551CP	281551, P0591-576-00025	L240X	Nozzle - 2.5 mm HD CP	1
	PT345-1552CP		L936X	Nozzle - 2.75 mm HD CP	1
	PT345-0002CP		L241X	Nozzle - 3.0 mm HD CP	1
	PT345-0005CP		L826X	Nozzle - 3.2 mm HD CP	1
	PT345-0006CP		L827X	Nozzle - 3.5 mm HD CP	1
	PT345-0004CP		L828X	Nozzle - 4.0 mm HD CP	1
	PT345-0007CP		L829X	Nozzle - 4.5 mm HD CP	1

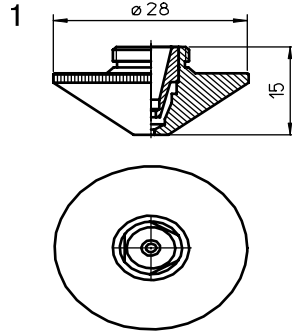

Consumables

	Centricut part number	Reference number	Alternate reference	Description	Pkg qty
1	PT358-0669	Centricut design	L669	Nozzle - 0.8 mm double	1
	PT358-0010	Centricut design	L660	Nozzle - 1.0 mm double	1
	PT358-0125	Centricut design	L661	Nozzle - 1.2 mm double	1
	PT358-0015	Centricut design	L662	Nozzle - 1.5 mm double	1
	PT358-0018	Centricut design	L663	Nozzle - 1.8 mm double	1
	PT358-0020	Centricut design	L664	Nozzle - 2.0 mm double	1
	PT358-0023	Centricut design	L665	Nozzle - 2.3 mm double	1
	PT358-0007	Centricut design	L666	Nozzle - 2.5 mm double	1
	PT358-0030	Centricut design	L667	Nozzle - 3.0 mm double	1
	PT358-0035	Centricut design	L668	Nozzle - 3.5 mm double	1
	PT358-0008CP	Centricut design	L669X	Nozzle - 0.8 mm double CP	1
	PT358-0010CP	Centricut design	L660X	Nozzle - 1.0 mm double CP	1
	PT358-0125CP	Centricut design	L661X	Nozzle - 1.2 mm double CP	1
	PT358-0015CP	Centricut design	L662X	Nozzle - 1.5 mm double CP	1
	PT358-0018CP	Centricut design	L663X	Nozzle - 1.8 mm double CP	1
	PT358-0020CP	Centricut design	L664X	Nozzle - 2.0 mm double CP	1
	PT358-0023CP	Centricut design	L665X	Nozzle - 2.3 mm double CP	1
	PT358-0025CP	Centricut design	L666X	Nozzle - 2.5 mm double CP	1
	PT358-0030CP	Centricut design	L667X	Nozzle - 3.0 mm double CP	1
	PT358-0035CP	Centricut design	L668X	Nozzle - 3.5 mm double CP	1

Optics

Centricut part number	Reference number	Type	Diameter	Focal length	Edge thickness
Lenses					
HW405-5270 NEW	355270	MEN	2.0"	5.0"	.378"

Optics care

Centricut part number	Reference number	Description	Pkg qty
TR300-6452	N/A	Lens cleaning paper, Tiffen - 50 piece	1
AM313-SC50 NEW	SC50	Lens cleaning paper, Tresor - 50 piece	1
TR300-1115		Lens cleaning pre-cut cotton - 80 piece	1
TR300-SC20		Cotton swab - 20 piece	1
TR300-1010	AL1010	Dropper, lens cleaning fluid	1
TR300-255	AL255	Loupe, magnifying	1
TR300-271	AL271	Base, lens maintenance	1
TR300-7388	787388	Mirror polish (250 ml)	1
AM313-1260 NEW	351260-009	Lens Polarizing Filter - 1.5"	1
AM313-1280 NEW	351280-009	Lens Polarizing Filter - 2.0"	1

Consumables

	Centricut part number	Reference number	Alternate reference	Description	Pkg qty
1	LD100-5213	605213-001	L1141	Nozzle - 1.5 mm	1
	LD100-0001		L1146	Nozzle - 1.75 mm	1

Optics care

Centricut part number	Reference number	Description	Pkg qty
TR300-6452	N/A	Lens cleaning paper, Tiffen - 50 piece	1
AM313-SC50 NEW	SC50	Lens cleaning paper, Tresor - 50 piece	1
TR300-1115		Lens cleaning pre-cut cotton - 80 piece	1
TR300-SC20		Cotton swab - 20 piece	1
TR300-1010	AL1010	Dropper, lens cleaning fluid	1
TR300-255	AL255	Loupe, magnifying	1
TR300-271	AL271	Base, lens maintenance	1
TR300-7388	787388	Mirror polish (250 ml)	1
AM313-1260 NEW	351260-009	Lens Polarizing Filter - 1.5"	1
AM313-1280 NEW	351280-009	Lens Polarizing Filter - 2.0"	1

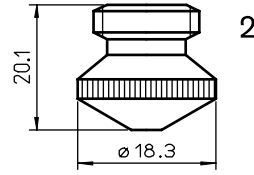
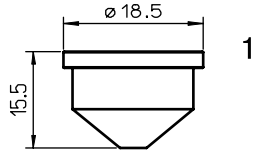
Consumables

	Centricut part number	Reference number	Alternate reference	Description	Pkg qty
1	LL340-210T	03-210T	L510	Nozzle - 1.0 mm	1
	LL340-212T	03-212T	L511	Nozzle - 1.2 mm	1
	LL340-214T	03-214T	L512	Nozzle - 1.4 mm	1
	LL340-217T	03-217T	L513	Nozzle - 1.7 mm	1
	LL340-220T	03-220T	L514	Nozzle - 2.0 mm	1
	LL340-224T	03-224T	L515	Nozzle - 2.4 mm	1
	LL340-230T	03-230T	L516	Nozzle - 3.0 mm	1
	2	LL341-2293-0.5	142081	L518	Nozzle - 0.5 mm
LL341-2293-1.0		00-2293-1.0	L519	Nozzle - 1.0 mm	1
LL341-2293-1.2		00-2293	L520	Nozzle - 1.2 mm	1
LL341-2293-1.5		142140	L521	Nozzle - 1.5 mm	1
LL341-2293-1.8		03-2293-1.8	L522	Nozzle - 1.8 mm	1
LL341-2293-2.0		142112	L523	Nozzle - 2.0 mm	1
LL341-2293-2.8		142112	L524	Nozzle - 2.8 mm	1

Optics

Centricut part number	Reference number	Type	Diameter	Focal length	Edge thickness
Lenses					
LL342-1819	166634, 61819	MEN	1.1"	5.0"	.236"
LL342-1014	61014, 406294, 658108	MEN	1.5"	5.0"	.290"
LL342-1171	61171	MEN	1.5"	7.5"	.300"

Optics care

Centricut part number	Reference number	Description	Pkg qty
TR300-6452	N/A	Lens cleaning paper, Tiffen - 50 piece	1
AM313-SC50 NEW	SC50	Lens cleaning paper, Tresor - 50 piece	1
TR300-1115		Lens cleaning pre-cut cotton - 80 piece	1
TR300-SC20		Cotton swab - 20 piece	1
TR300-1010	AL1010	Dropper, lens cleaning fluid	1
TR300-255	AL255	Loupe, magnifying	1
TR300-271	AL271	Base, lens maintenance	1
TR300-7388	787388	Mirror polish (250 ml)	1
AM313-1260 NEW	351260-009	Lens Polarizing Filter - 1.5"	1
AM313-1280 NEW	351280-009	Lens Polarizing Filter - 2.0"	1

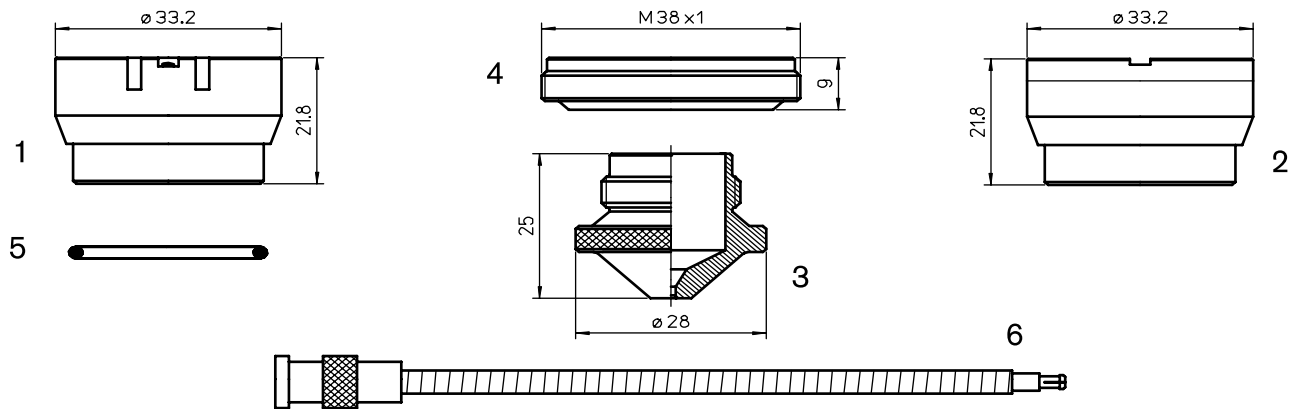
Consumables

	Centricut part number	Reference number	Alternate reference	Description	Pkg qty
1	PT311-1146	281146, P0380-211-00001, 29100033	AL130/S	Nozzle holder - ITM 1.5" DZ (aluminum)	1
	PT311-1146 OEM	281146, P0380-211-00001, 29100033	AL130	Nozzle holder - ITM 1.5" DZ (OEM) (aluminum)	1
2	PT311-0565	280565, P0497-605-00001, 29100106	AL40	Nozzle holder - KTM 1.5" DXN (ceramic)	1
3	LV332-1993	D5241993	L757	Nozzle - 0.8 mm (cylindrical)	1
	LV332-5470	D7945470	L141	Nozzle - 1.0 mm (cylindrical)	1
	LV332-0001	D5241982	L758	Nozzle - 1.2 mm (cylindrical)	1
	LV332-5434	D7945434	L142	Nozzle - 1.5 mm (cylindrical)	1
	LV332-5452	D7945452	L143	Nozzle - 2.0 mm (cylindrical)	1
	LV332-5517	D7945517	L144	Nozzle - 2.5 mm (cylindrical)	1
	LV332-0002		L145	Nozzle - 3.0 mm (cylindrical)	1
	LV332-1993CP	D5241993	L757X	Nozzle - 0.8 mm CP (cylindrical)	1
	LV332-5470CP	D7945470	L141X	Nozzle - 1.0 mm CP (cylindrical)	1
	LV332-0001CP	D5241982	L758X	Nozzle - 1.2 mm CP (cylindrical)	1
	LV332-5434CP	D7945434	L142X	Nozzle - 1.5 mm CP (cylindrical)	1
	LV332-5452CP	D7945452	L143X	Nozzle - 2.0 mm CP (cylindrical)	1
	LV332-5517CP	D7945517	L144X	Nozzle - 2.5 mm CP (cylindrical)	1
	LV332-0002CP		L145X	Nozzle - 3.0 mm CP (cylindrical)	1
4	PT347-4297	P0492-702-00001, 29100021	AL198	Insulating ring (plastic)	1
	PT311-0001	P0492-702-00002	AL201	Insulating ring (plastic)	1
5	AM326-6453	71366453	AL94	O-ring for outer nozzle	1
6	PT347-0101	P0360-100-00500, 46713300100	AL204	Sensor cable 500 mm KE (OEM)	1
	PT347-0450	P0497-002-00450	AL202	Sensor cable 450 mm (OEM)	1

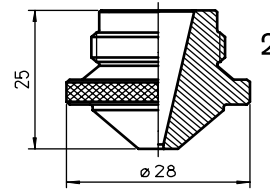
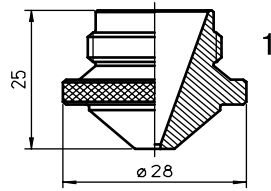
Consumables

	Centricut part number	Reference number	Alternate reference	Description	Pkg qty
1	LV332-1863	D5241863	L151	Nozzle - 1.0 mm HD (conical)	1
	LV332-1982		L759	Nozzle - 1.2 mm HD (conical)	1
	LV332-1862	D5241862	L152	Nozzle - 1.5 mm HD (conical)	1
	LV332-2512	D5242512	L748	Nozzle - 1.7 mm HD (conical)	1
	LV332-1855	D5241855	L146	Nozzle - 2.0 mm HD (conical)	1
	LV332-2513	D5242513, Z000000539D	L749	Nozzle - 2.3 mm HD (conical)	1
	LV332-1856	D5241856, Z000000563B	L147	Nozzle - 2.5 mm HD (conical)	1
	LV332-1857	D5241857, Z000000540B	L148	Nozzle - 3.0 mm HD (conical)	1
	LV332-1877	D5241877, Z000000564B	L149	Nozzle - 3.5 mm HD (conical)	1
	LV332-1878	D5241878, Z000000565B	L283	Nozzle - 4.0 mm HD (conical)	1
	LV332-2531	D5242531, Z000000566B	L1303	Nozzle - 4.5 mm HD (conical)	1
	LV332-2535	D5242535, Z000000567B	L1304	Nozzle - 5.0 mm HD (conical)	1
	LV332-2536	D5242536, Z000000568B	L1305	Nozzle - 6.0 mm HD (conical)	1
	LV332-1863CP	D5241863	L151X	Nozzle - 1.0 mm HD CP (conical)	1
	LV332-1982CP		L759X	Nozzle - 1.2 mm HD CP (conical)	1
	LV332-1862CP	D5241862	L152X	Nozzle - 1.5 mm HD CP (conical)	1
	LV332-2512CP	D5242512	L748X	Nozzle - 1.7 mm HD CP (conical)	1
	LV332-1855CP	D5241855	L146X	Nozzle - 2.0 mm HD CP (conical)	1
	LV332-2513CP	D5242513	L749X	Nozzle - 2.3 mm HD CP (conical)	1
	LV332-1856CP	D5241856	L147X	Nozzle - 2.5 mm HD CP (conical)	1
LV332-1857CP	D5241857	L148X	Nozzle - 3.0 mm HD CP (conical)	1	
LV332-1877CP	D5241877	L149X	Nozzle - 3.5 mm HD CP (conical)	1	
LV332-1878CP	D5241878	L283X	Nozzle - 4.0 mm HD CP (conical)	1	
2	LV332-2453	D5242453A	L152-S	Nozzle - 1.5 mm HD	1
	LV332-2454	D5242454A	L146-S	Nozzle - 2.0 mm HD	1
	LV332-2416	D5242416A	L147-S	Nozzle - 2.5 mm HD	1
	LV332-2455	D5242455 A	L148-S	Nozzle - 3.0 mm HD	1

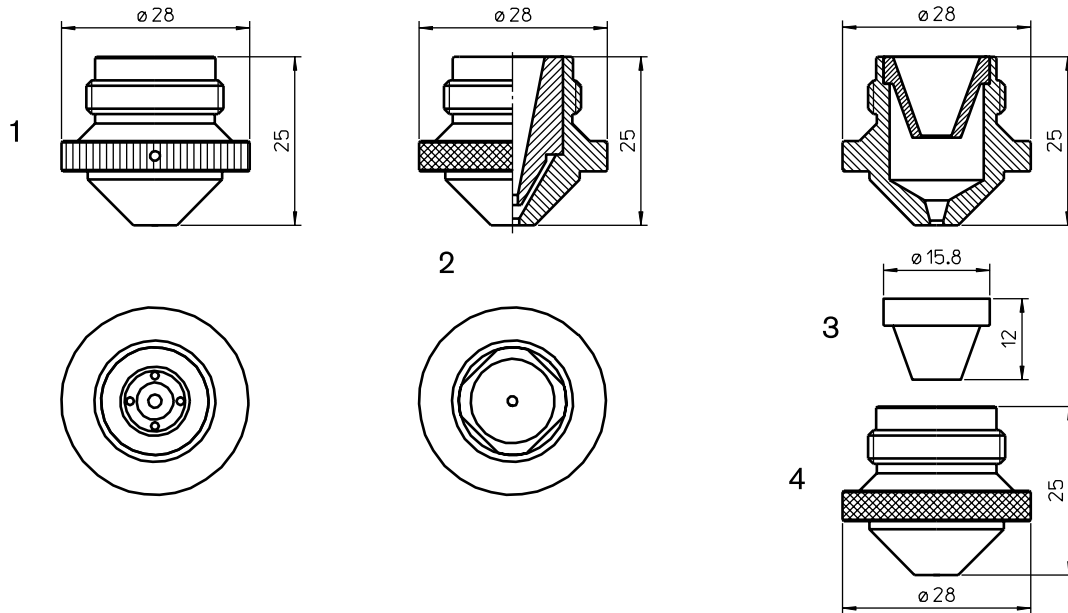
Consumables

	Centricut part number	Reference number	Alternate reference	Description	Pkg qty
1	LV332-0013	G8040180	L1290	Nozzle - 2.5 mm double w/spring 1.3 mm inner	1
	LV332-0180	G8040135	L1291	Nozzle - 2.5 mm double w/spring 1.5 mm inner	1
	LV332-3013	G8040182	L1293	Nozzle - 3.0 mm double w/spring 1.3 mm inner	1
	LV332-3015		L1294	Nozzle - 3.0 mm double w/spring 1.5 mm inner	1
	LV332-0132	G8040132	L1292	Nozzle - 3.0 mm double w/spring 2.0 mm inner	1
	LV332-0013CP	G8040180	L1290X	Nozzle - 2.5 mm double w/spring 1.3 mm inner CP	1
	LV332-0180CP	G8040135	L1291X	Nozzle - 2.5 mm double w/spring 1.5 mm inner CP	1
	LV332-3013CP	G8040182	L1293X	Nozzle - 3.0 mm double w/spring 1.3 mm inner CP	1
	LV332-3015CP		L1294X	Nozzle - 3.0 mm double w/spring 1.5 mm inner CP	1
	LV332-0132CP	G8040132	L1292X	Nozzle - 3.0 mm double w/spring 2.0 mm inner CP	1
2	LV417-0001	Centricut design	L783	Nozzle - 1.0 mm double	1
	LV417-0002	Centricut design	L782	Nozzle - 1.2 mm double	1
	LV417-0003	Centricut design	L784	Nozzle - 1.5 mm double	1
	LV417-0004	Centricut design	L785	Nozzle - 2.0 mm double	1
	LV410-0180	Centricut design	L786	Nozzle - 2.5 mm double	1
	LV417-0006	Centricut design	L787	Nozzle - 3.0 mm double	1
	LV417-0007	Centricut design	L788	Nozzle - 3.5 mm double	1
	LV417-0008	Centricut design	L789	Nozzle - 4.0 mm double	1
	LV417-0001CP	Centricut design	L783X	Nozzle - 1.0 mm double CP	1
	LV417-0002CP	Centricut design	L782X	Nozzle - 1.2 mm double CP	1
	LV417-0003CP	Centricut design	L784X	Nozzle - 1.5 mm double CP	1
	LV417-0004CP	Centricut design	L785X	Nozzle - 2.0 mm double CP	1
	LV417-0005CP	Centricut design	L786X	Nozzle - 2.5 mm double CP	1
	LV417-0006CP	Centricut design	L787X	Nozzle - 3.0 mm double CP	1
	LV417-0007CP	Centricut design	L788X	Nozzle - 3.5 mm double CP	1
	LV417-0008CP	Centricut design	L789X	Nozzle - 4.0 mm double CP	1
LV332-0130	Z00000223A	L791	Nozzle - 3.0 mm double	1	
LV332-0131	G8040131	L790	Nozzle - 3.0 mm double	1	
3	LV418-0001	Centricut design	L157	Nozzle, inner	1
4	LV418-0010	Centricut design	L158	Nozzle - 1.0 mm (for inner nozzle)	1
	LV418-0003	Centricut design	L934	Nozzle - 1.2 mm (for inner nozzle)	1
	LV418-0004	Centricut design	L159	Nozzle - 1.5 mm (for inner nozzle)	1
	LV418-0005	Centricut design	L160	Nozzle - 2.0 mm (for inner nozzle)	1
	LV418-0006	Centricut design	L161	Nozzle - 2.5 mm (for inner nozzle)	1
	LV418-0007	Centricut design	L178	Nozzle - 3.0 mm (for inner nozzle)	1
	LV418-0008	Centricut design	L179	Nozzle - 3.5 mm (for inner nozzle)	1

Optics

Centricut part number	Reference number	Type	Diameter	Focal length	Edge thickness
Lenses					
LV333-0023	29100023	MEN	1.5"	5.0"	.290"
LV333-0176	480176	MEN	1.75"	5.0"	.354"
LV333-6326	206326	MEN	2.0"	5.0"	.354"
LV333-1004	458138	MEN	2.0"	5.0"	.380"
LV333-1005	291005-5	MEN	2.0"	7.5"	.380"
LV333-1551	981551	MEN	2.0"	10.0"	.378"
Ultra low absorption lenses					
LV333-0023MP5	29100023	MEN	1.5"	5.0"	.290"
LV333-1005MP5	291005-5	MEN	1.5"	7.5"	.380"

Centricut part number	Reference number	Material	Diameter	Edge thickness	S1/Reflectivity	S2
Output couplers						
LV333-7295	897295	ZNSE	1.5"	.315"	30MCC-50%	30MCX
Rear mirrors						
LV333-6659	966659	GE	1.5"	.315"	30MCC-99.5%	

Centricut part number	Reference number	Type	Material	Diameter	Edge thickness	S1
Zero phase shift mirrors and total reflectors						
LV333-6858	NEW 126858	TRZ	CU	2.0"	.375"	45DEG

Optics care

Centricut part number	Reference number	Description	Pkg qty
TR300-6452	N/A	Lens cleaning paper, Tiffen – 50 piece	1
AM313-SC50	NEW SC50	Lens cleaning paper, Tresor – 50 piece	1
TR300-1115		Lens cleaning pre-cut cotton – 80 piece	1
TR300-SC20		Cotton swab – 20 piece	1
TR300-1010	AL1010	Dropper, lens cleaning fluid	1
TR300-255	AL255	Loupe, magnifying	1
TR300-271	AL271	Base, lens maintenance	1
TR300-7388	787388	Mirror polish (250 ml)	1
AM313-1260	NEW 351260-009	Lens Polarizing Filter – 1.5"	1
AM313-1280	NEW 351280-009	Lens Polarizing Filter – 2.0"	1

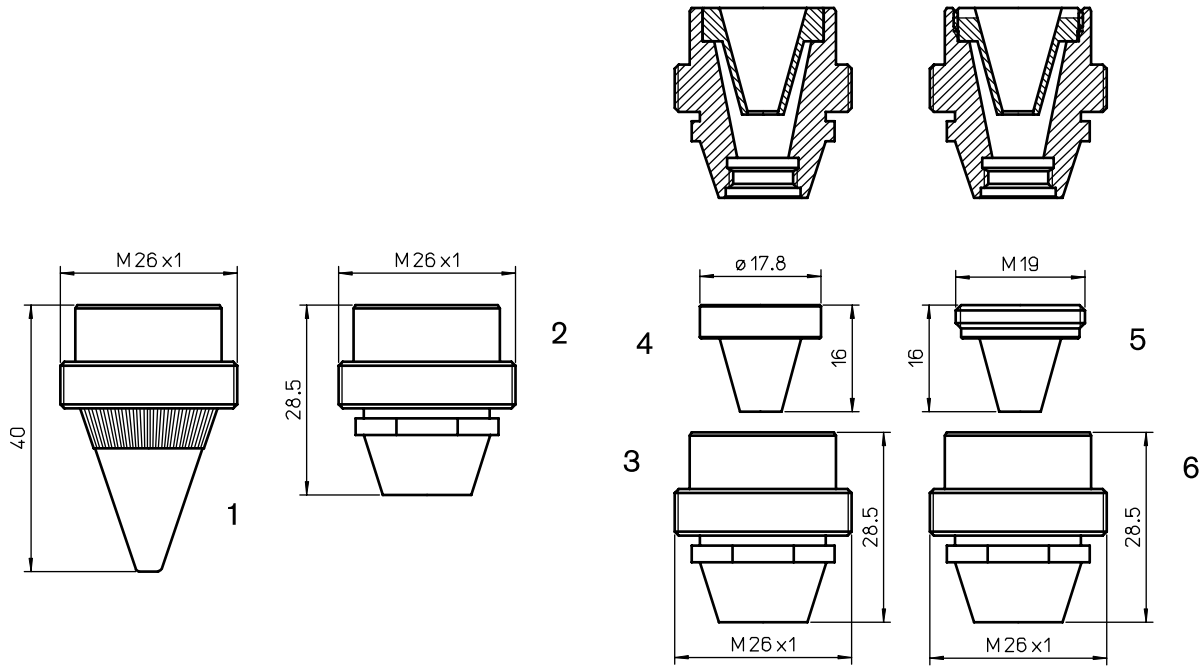

Consumables

	Centricut part number	Reference number	Alternate reference	Description	Pkg qty
1	MZ323-0060-1.0	46523300060	L61	Nozzle - 1.0 mm	1
	MZ323-0062-1.2	46523300062	L60	Nozzle - 1.2 mm	1
	MZ323-0061-1.5	46523300061	L84	Nozzle - 1.5 mm	1
	MZ323-0061-1.7	46523300061	L4	Nozzle - 1.7 mm	1
	MZ323-0018		L331	Nozzle - 1.8 mm	1
	MZ323-0063-2.0	46523300063	L51	Nozzle - 2.0 mm	1
	MZ323-0063-2.5	46523300063	L333	Nozzle - 2.5 mm	1
2	MZ321-0510	46603350510	AL11	Nozzle adaptor	1
3	MZ321-0001	Centricut design	AL44	Nozzle adaptor	1
4	MZ321-0045	Centricut design	AL45	Nozzle, inner	1
5	MZ321-0055	Centricut design	AL55	Nozzle, inner	1
6	MZ331-0003	Centricut design	AL54	Nozzle adaptor	1

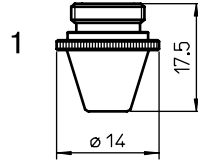

Consumables

	Centricut part number	Reference number	Alternate reference	Description	Pkg qty
	MZ322-0008	46603350508	L78	Nozzle - 0.8 mm	1
	MZ322-0008X	46603350508	L3078	Nozzle - 0.8 mm (10 pack)	10
	MZ322-0511-1.0	46603350511	L69	Nozzle - 1.0 mm	1
	MZ322-0511X	46603350511	L3069	Nozzle - 1.0 mm (10 pack)	10
	MZ322-0512-1.2	46603350512	L77	Nozzle - 1.2 mm	1
	MZ322-0512X	46603350512	L3077	Nozzle - 1.2 mm (10 pack)	10
	MZ322-0520-1.5	4660335052B	L127	Nozzle - 1.5 mm	1
	PT322-0520X	4660335052B	L30127	Nozzle - 1.5 mm (10 pack)	10
	MZ322-0517-1.7	46603350517	L79	Nozzle - 1.7 mm	1
	MZ322-1517X	46603350517	L3079	Nozzle - 1.7 mm (10 pack)	10
	MZ322-0517	46603350517-1.8	L281	Nozzle - 1.8 mm	1
	MZ322-0517X	46603350517-1.8	L30281	Nozzle - 1.8 mm (10 pack)	10
	MZ322-0522-2.0	4660335052C	L80	Nozzle - 2.0 mm	1
	MZ322-0522X	4660335052C	L3080	Nozzle - 2.0 mm (10 pack)	10
1	MZ322-0022	46603350522-2.2	L282	Nozzle - 2.2 mm	1
	MZ322-0022X	46603350522-2.2	L30282	Nozzle - 2.2 mm (10 pack)	10
	MZ322-0525-2.5	46603350525	L124	Nozzle - 2.5 mm	1
	MZ322-0025X	46603350525	L30124	Nozzle - 2.5 mm (10 pack)	10
	MZ322-0530-3.0	46603350530	L150	Nozzle - 3.0 mm	1
	MZ322-0030X	46603350530	L30150	Nozzle - 3.0 mm (10 pack)	10
	MZ322-0530-3.5	46603350530-3.5	L708	Nozzle - 3.5 mm	1
	MZ322-1035X	46603350530-3.5	L30708	Nozzle - 3.5 mm (10 pack)	10
	MZ322-0530-4.0	46603350530-4.0	L709	Nozzle - 4.0 mm	1
	MZ322-1040X	46603350530-4.0	L30709	Nozzle - 4.0 mm (10 pack)	10
	MZ322-1045	46603350530-4.5	L710	Nozzle - 4.5 mm	1
	MZ322-1045X	46603350530-4.5	L30710	Nozzle - 4.5 mm (10 pack)	10
	MZ322-1050	46603350530-5.0	L711	Nozzle - 5.0 mm	1
	MZ322-1050X	46603350530-5.0	L30711	Nozzle - 5.0 mm (10 pack)	10

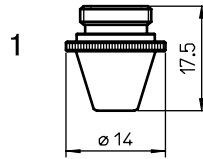

Consumables

	Centricut part number	Reference number	Alternate reference	Description	Pkg qty
	MZ322-0008CP	46603350508	L78X	Nozzle - 0.8 mm CP	1
	MZ322-0008CPX	46603350508	L3078X	Nozzle - 0.8 mm CP (10 pack)	10
	MZ322-0511CP	46603350511	L69X	Nozzle - 1.0 mm CP	1
	MZ322-0511CPX	46603350511	L3069X	Nozzle - 1.0 mm CP (10 pack)	10
	MZ322-0512CP	46603350512	L77X	Nozzle - 1.2 mm CP	1
	MZ322-0512CPX	46603350512	L3077X	Nozzle - 1.2 mm CP (10 pack)	10
	MZ322-0520CP	4660335052B	L127X	Nozzle - 1.5 mm CP	1
	PT322-0520CPX	4660335052B	L30127X	Nozzle - 1.5 mm CP (10 pack)	10
	MZ322-1517CP	46603350517	L79X	Nozzle - 1.7 mm CP	1
	MZ322-1517CPX	46603350517	L3079X	Nozzle - 1.7 mm CP (10 pack)	10
	MZ322-0517CP	46603350517-1.8	L281X	Nozzle - 1.8 mm CP	1
	MZ322-0517CPX	46603350517-1.8	L30281X	Nozzle - 1.8 mm CP (10 pack)	10
	MZ322-0522CP	4660335052C	L80X	Nozzle - 2.0 mm CP	1
1	MZ322-0522CPX	4660335052C	L3080X	Nozzle - 2.0 mm CP (10 pack)	10
	MZ322-0022CP	46603350522-2.2	L282X	Nozzle - 2.2 mm CP	1
	MZ322-0022CPX	46603350522-2.2	L30282X	Nozzle - 2.2 mm CP (10 pack)	10
	MZ322-0025CP	46603350525	L124X	Nozzle - 2.5 mm CP	1
	MZ322-0025CPX	46603350525	L30124X	Nozzle - 2.5 mm CP (10 pack)	10
	MZ322-0030CP	46603350530	L150X	Nozzle - 3.0 mm CP	1
	MZ322-0030CPX	46603350530	L30150X	Nozzle - 3.0 mm CP (10 pack)	10
	MZ322-1035CP	46603350530-3.5	L708X	Nozzle - 3.5 mm CP	1
	MZ322-1035CPX	46603350530-3.5	L30708X	Nozzle - 3.5 mm CP (10 pack)	10
	MZ322-1040CP	46603350530-4.0	L709X	Nozzle - 4.0 mm CP	1
	MZ322-1040CPX	46603350530-4.0	L30709X	Nozzle - 4.0 mm CP (10 pack)	10
	MZ322-1045CP	46603350530-4.5	L710X	Nozzle - 4.5 mm CP	1
	MZ322-1045CPX	46603350530-4.5	L30710X	Nozzle - 4.5 mm CP (10 pack)	10
	MZ322-1050CP	46603350530-5.0	L711X	Nozzle - 5.0 mm CP	1
	MZ322-1050CPX	46603350530-5.0	L30711X	Nozzle - 5.0 mm CP (10 pack)	10

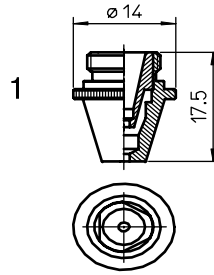

Consumables

Centricut part number	Reference number	Alternate reference	Description	Pkg qty
MZ346-0001	Centricut design	L615	Nozzle - 1.0 mm double	1
MZ346-0001X	Centricut design	L30615	Nozzle - 1.0 mm double (10 pack)	10
MZ346-0002	Centricut design	L616	Nozzle - 1.2 mm double	1
MZ346-0002X	Centricut design	L30616	Nozzle - 1.2 mm double (10 pack)	10
MZ346-0003	Centricut design	L617	Nozzle - 1.5 mm double	1
MZ346-0003X	Centricut design	L30617	Nozzle - 1.5 mm double (10 pack)	10
MZ346-0004	Centricut design	L618	Nozzle - 1.7 mm double	1
MZ346-0004X	Centricut design	L30618	Nozzle - 1.7 mm double (10 pack)	10
MZ346-0005	Centricut design	L619	Nozzle - 1.8 mm double	1
MZ346-0005X	Centricut design	L30619	Nozzle - 1.8 mm double (10 pack)	10
MZ346-0006	Centricut design	L620	Nozzle - 2.0 mm double	1
MZ346-0006X	Centricut design	L30620	Nozzle - 2.0 mm double (10 pack)	10
MZ346-0007	Centricut design	L621	Nozzle - 2.2 mm double	1
MZ346-0007X	Centricut design	L30621	Nozzle - 2.2 mm double (10 pack)	10
MZ346-0008	Centricut design	L622	Nozzle - 2.5 mm double	1
MZ346-0008X	Centricut design	L30622	Nozzle - 2.5 mm double (10 pack)	10
MZ346-0009	Centricut design	L623	Nozzle - 3.0 mm double	1
MZ346-0009X	Centricut design	L30623	Nozzle - 3.0 mm double (10 pack)	10
MZ346-0001CP	Centricut design	L615X	Nozzle - 1.0 mm CP double	1
MZ346-0001CPX	Centricut design	L30615X	Nozzle - 1.0 mm CP double (10 pack)	10
MZ346-0002CP	Centricut design	L616X	Nozzle - 1.2 mm CP double	1
MZ346-0002CPX	Centricut design	L30616X	Nozzle - 1.2 mm CP double (10 pack)	10
MZ346-0003CP	46683302380	L617X	Nozzle - 1.5 mm CP double	1
MZ346-0003CPX	Centricut design	L30617X	Nozzle - 1.5 mm CP double (10 pack)	10
MZ346-0004CP	Centricut design	L618X	Nozzle - 1.7 mm CP double	1
MZ346-0004CPX	Centricut design	L30618X	Nozzle - 1.7 mm CP double (10 pack)	10
MZ346-0005CP	Centricut design	L619X	Nozzle - 1.8 mm CP double	1
MZ346-0005CPX	Centricut design	L30619X	Nozzle - 1.8 mm CP double (10 pack)	10
MZ346-0006CP	46683302390	L620X	Nozzle - 2.0 mm CP double	1
MZ346-0006CPX	Centricut design	L30620X	Nozzle - 2.0 mm CP double (10 pack)	10
MZ346-0007CP	Centricut design	L621X	Nozzle - 2.2 mm CP double	1
MZ346-0007CPX	Centricut design	L30621X	Nozzle - 2.2 mm CP double (10 pack)	10
MZ346-0008CP	46683302400	L622X	Nozzle - 2.5 mm CP double	1
MZ346-0008CPX	Centricut design	L30622X	Nozzle - 2.5 mm CP double (10 pack)	10
MZ346-0009CP	46683302410	L623X	Nozzle - 3.0 mm CP double	1
MZ346-0009CPX	Centricut design	L30623X	Nozzle - 3.0 mm CP double (10 pack)	10

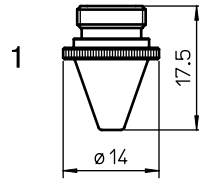

Consumables

Centricut part number	Reference number	Alternate reference	Description	Pkg qty
MZ321-0521-0.8	46603350521	L266	Nozzle - 0.8 mm	1
MZ321-0008X	46603350521	L30266	Nozzle - 0.8 mm (10 pack)	10
MZ321-0521-1.0	46603350521	L250	Nozzle - 1.0 mm	1
MZ321-0010X	46603350521	L30250	Nozzle - 1.0 mm (10 pack)	10
MZ321-0521-1.2	46603350521	L251	Nozzle - 1.2 mm	1
MZ321-0012X	46603350521	L30251	Nozzle - 1.2 mm (10 pack)	10
MZ321-0520-1.5	46603350520	L252	Nozzle - 1.5 mm	1
MZ321-0520X	46603350520	L30252	Nozzle - 1.5 mm (10 pack)	10
MZ321-0521-1.7	46603350521	L253	Nozzle - 1.7 mm	1
MZ321-0017X	46603350521	L30253	Nozzle - 1.7 mm (10 pack)	10
MZ321-0522-2.0	46603350522	L254	Nozzle - 2.0 mm	1
MZ321-0054X	46603350522	L30254	Nozzle - 2.0 mm (10 pack)	10
MZ321-0522-2.5	46603350522	L770	Nozzle - 2.5 mm	1
MZ321-1025X	46603350522	L30770	Nozzle - 2.5 mm (10 pack)	10
MZ321-0522-3.0	46683301281	L771	Nozzle - 3.0 mm	1
MZ321-1030X	46683301281	L30771	Nozzle - 3.0 mm (10 pack)	10
MZ321-0008CP	46603350521	L266X	Nozzle - 0.8 mm CP	1
MZ321-0008CPX	46603350521	L30266X	Nozzle - 0.8 mm CP (10 pack)	10
MZ321-0010CP	46603350521	L250X	Nozzle - 1.0 mm CP	1
MZ321-0010CPX	46603350521	L30250X	Nozzle - 1.0 mm CP (10 pack)	10
MZ321-521-1.2CP	46603350521	L251X	Nozzle - 1.2 mm CP	1
MZ321-0012CPX	46603350521	L30251X	Nozzle - 1.2 mm CP (10 pack)	10
MZ321-520-1.5CP	46603350520	L252X	Nozzle - 1.5 mm CP	1
MZ321-0520CPX	46603350520	L30252X	Nozzle - 1.5 mm CP (10 pack)	10
MZ321-0017CP	46603350521	L253X	Nozzle - 1.7 mm CP	1
MZ321-0017CPX	46603350521	L30253X	Nozzle - 1.7 mm CP (10 pack)	10
MZ321-522-2.0CP	46603350522	L254X	Nozzle - 2.0 mm CP	1
MZ321-0054CPX	46603350522	L30254X	Nozzle - 2.0 mm CP (10 pack)	10
MZ321-522-2.5CP	46603350522	L770X	Nozzle - 2.5 mm CP	1
MZ321-1025CPX	46603350522	L30770X	Nozzle - 2.5 mm CP (10 pack)	10
MZ321-522-3.0CP	46683301281	L771X	Nozzle - 3.0 mm CP	1
MZ321-1030CPX	46683301281	L30771X	Nozzle - 3.0 mm CP (10 pack)	10

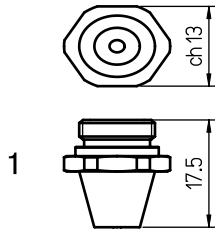

Consumables

	Centricut part number	Reference number	Alternate reference	Description	Pkg qty
	MZ385-0508	46603350508	L725	Nozzle - 0.8 mm hex	1
	MZ385-0508X	46603350508	L30725	Nozzle - 0.8 mm hex (10 pack)	10
	MZ385-0511	46603350511	L726	Nozzle - 1.0 mm hex	1
	MZ385-0511X	46603350511	L30726	Nozzle - 1.0 mm hex (10 pack)	10
	MZ385-5052	4660335052A	L727	Nozzle - 1.2 mm hex	1
	MZ385-5052X	4660335052A	L30727	Nozzle - 1.2 mm hex (10 pack)	10
	MZ385-5052B	4660335052B	L728	Nozzle - 1.5 mm hex	1
	MZ385-5052BX	4660335052B	L30728	Nozzle - 1.5 mm hex (10 pack)	10
	MZ385-0517	46603350517	L729	Nozzle - 1.7 mm hex	1
	MZ385-0517X	46603350517	L30729	Nozzle - 1.7 mm hex (10 pack)	10
	MZ385-517	46603350517-1.8	L730	Nozzle - 1.8 mm hex	1
	MZ385-517X	46603350517-1.8	L30730	Nozzle - 1.8 mm hex (10 pack)	10
1	MZ385-5052C	4660335052C	L731	Nozzle - 2.0 mm hex	1
	MZ385-5052CX	4660335052C	L30731	Nozzle - 2.0 mm hex (10 pack)	10
	MZ385-0522	46603350522-2.2	L732	Nozzle - 2.2 mm hex	1
	MZ385-0522X	46603350522-2.2	L30732	Nozzle - 2.2 mm hex (10 pack)	10
	MZ385-0003	4660335052D	L733	Nozzle - 2.5 mm hex	1
	MZ385-0003X	4660335052D	L30733	Nozzle - 2.5 mm hex (10 pack)	10
	MZ385-1003	46603350530	L734	Nozzle - 3.0 mm hex	1
	MZ385-1003X	46603350530	L30734	Nozzle - 3.0 mm hex (10 pack)	10
	MZ385-0030	46603350530-3.5	L735	Nozzle - 3.5 mm hex	1
	MZ385-0030X	46603350530-3.5	L30735	Nozzle - 3.5 mm hex (10 pack)	10
	MZ385-0530	46603350530-4.0	L736	Nozzle - 4.0 mm hex	1
	MZ385-0530X	46603350530-4.0	L30736	Nozzle - 4.0 mm hex (10 pack)	10
	MZ385-530	46603350530-4.5	L737	Nozzle - 4.5 mm hex	1
	MZ385-530X	46603350530-4.5	L30737	Nozzle - 4.5 mm hex (10 pack)	10

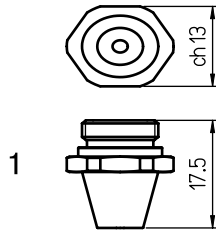

Consumables

	Centricut part number	Reference number	Alternate reference	Description	Pkg qty
1	MZ385-0508CP	46603350508	L725X	Nozzle - 0.8 mm hex CP	1
	MZ385-0508CPX	46603350508	L30725X	Nozzle - 0.8 mm hex CP (10 pack)	10
	MZ385-0511CP	46603350511	L726X	Nozzle - 1.0 mm hex CP	1
	MZ385-0511CPX	46603350511	L30726X	Nozzle - 1.0 mm hex CP (10 pack)	10
	MZ385-052CP	4660335052A	L727X	Nozzle - 1.2 mm hex CP	1
	MZ385-052CPX	4660335052A	L30727X	Nozzle - 1.2 mm hex CP (10 pack)	10
	MZ385-052CP	4660335052B	L728X	Nozzle - 1.5 mm hex CP	1
	MZ385-052CPX	4660335052B	L30728X	Nozzle - 1.5 mm hex CP (10 pack)	10
	MZ385-0517CP	46603350517	L729X	Nozzle - 1.7 mm hex CP	1
	MZ385-0517CPX	46603350517	L30729X	Nozzle - 1.7 mm hex CP (10 pack)	10
	MZ385-517CP	46603350517-1.8	L730X	Nozzle - 1.8 mm hex CP	1
	MZ385-517CPX	46603350517-1.8	L30730X	Nozzle - 1.8 mm hex CP (10 pack)	10
	MZ385-0052CP	4660335052C	L731X	Nozzle - 2.0 mm hex CP	1
	MZ385-0052CPX	4660335052C	L30731X	Nozzle - 2.0 mm hex CP (10 pack)	10
	MZ385-0522CP	46603350522-2.2	L732X	Nozzle - 2.2 mm hex CP	1
	MZ385-0522CPX	46603350522-2.2	L30732X	Nozzle - 2.2 mm hex CP (10 pack)	10
	MZ385-0003CP	4660335052D	L733X	Nozzle - 2.5 mm hex CP	1
	MZ385-0003CPX	4660335052D	L30733X	Nozzle - 2.5 mm hex CP (10 pack)	10
	MZ385-1003CP	46603350530	L734X	Nozzle - 3.0 mm hex CP	1
	MZ385-1003CPX	46603350530	L30734X	Nozzle - 3.0 mm hex CP (10 pack)	10
	MZ385-0030CP	46603350530-3.5	L735X	Nozzle - 3.5 mm hex CP	1
	MZ385-0030CPX	46603350530-3.5	L30735X	Nozzle - 3.5 mm hex CP (10 pack)	10
	MZ385-0530CP	46603350530-4.0	L736X	Nozzle - 4.0 mm hex CP	1
	MZ385-0530CPX	46603350530-4.0	L30736X	Nozzle - 4.0 mm hex CP (10 pack)	10
	MZ385-530CP	46603350530-4.5	L737X	Nozzle - 4.5 mm hex CP	1
	MZ385-530CPX	46603350530-4.5	L30737X	Nozzle - 4.5 mm hex CP (10 pack)	10

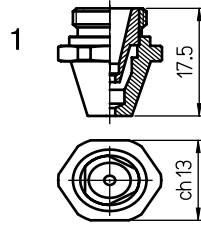

Consumables

	Centricut part number	Reference number	Alternate reference	Description	Pkg qty
	MZ419-0001		L1223	Nozzle - 1.2 mm double hex	1
	MZ419-0001X		L301223	Nozzle - 1.2 mm double hex (10 pack)	10
	MZ419-0002		L1224	Nozzle - 1.5 mm double hex	1
	MZ419-0002X		L301224	Nozzle - 1.5 mm double hex (10 pack)	10
	MZ419-0003		L1225	Nozzle - 1.8 mm double hex	1
	MZ419-0003X		L301225	Nozzle - 1.8 mm double hex (10 pack)	10
	MZ419-0004		L1226	Nozzle - 2.0 mm double hex	1
	MZ419-0004X		L301226	Nozzle - 2.0 mm double hex (10 pack)	10
	MZ419-0005		L1227	Nozzle - 2.2 mm double hex	1
	MZ419-0005X		L301227	Nozzle - 2.2 mm double hex (10 pack)	10
	MZ419-0006		L1228	Nozzle - 2.5 mm double hex	1
	MZ419-0006X		L301228	Nozzle - 2.5 mm double hex (10 pack)	10
	MZ419-0007		L1229	Nozzle - 3.0 mm double hex	1
	MZ419-0007X		L301229	Nozzle - 3.0 mm double hex (10 pack)	10
1	MZ419-0001CP		L1223X	Nozzle - 1.2 mm double hex CP	1
	MZ419-0001CPX		L301223X	Nozzle - 1.2 mm double hex CP (10 pack)	10
	MZ419-0002CP		L1224X	Nozzle - 1.5 mm double hex CP	1
	MZ419-0002CPX		L301224X	Nozzle - 1.5 mm double hex CP (10 pack)	10
	MZ419-0003CP		L1225X	Nozzle - 1.8 mm double hex CP	1
	MZ419-0003CPX		L301225X	Nozzle - 1.8 mm double hex CP (10 pack)	10
	MZ419-0004CP		L1226X	Nozzle - 2.0 mm double hex CP	1
	MZ419-0004CPX		L301226X	Nozzle - 2.0 mm double hex CP (10 pack)	10
	MZ419-0005CP		L1227X	Nozzle - 2.2 mm double hex CP	1
	MZ419-0005CPX		L301227X	Nozzle - 2.2 mm double hex CP (10 pack)	10
	MZ419-0006CP		L1228X	Nozzle - 2.5 mm double hex CP	1
	MZ419-0006CPX		L301228X	Nozzle - 2.5 mm double hex CP (10 pack)	10
	MZ419-0007CP		L1229X	Nozzle - 3.0 mm double hex CP	1
	MZ419-0007CPX		L301229X	Nozzle - 3.0 mm double hex CP (10 pack)	10

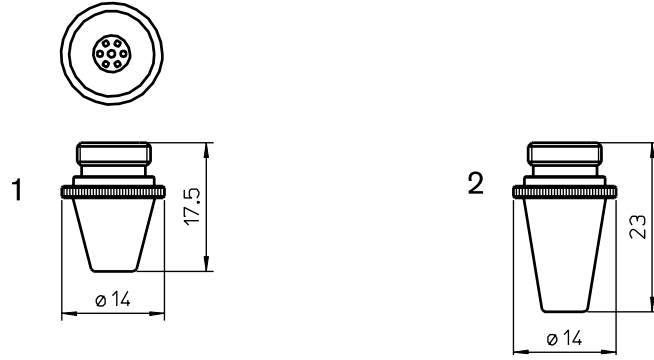

Consumables

	Centricut part number	Reference number	Alternate reference	Description	Pkg qty
1	MZ322-0523	46603350523	L492	Nozzle - 1.0 mm shower	1
	MZ322-0523-1.5		L493	Nozzle - 1.5 mm shower	1
	MZ322-0523-2.0		L497	Nozzle - 2.0 mm shower	1
	MZ322-0001		L284	Nozzle - 2.0 mm long	1
	MZ332-0002		L285	Nozzle - 2.5 mm long	1
	MZ332-0003		L286	Nozzle - 3.0 mm long	1
2	MZ322-0015CP		L373X	Nozzle - 1.5 mm CP long	1
	MZ322-0001CP		L284X	Nozzle - 2.0 mm CP long	1
	MZ332-0002CP		L285X	Nozzle - 2.5 mm CP long	1
	MZ332-0003CP		L286X	Nozzle - 3.0 mm CP long	1

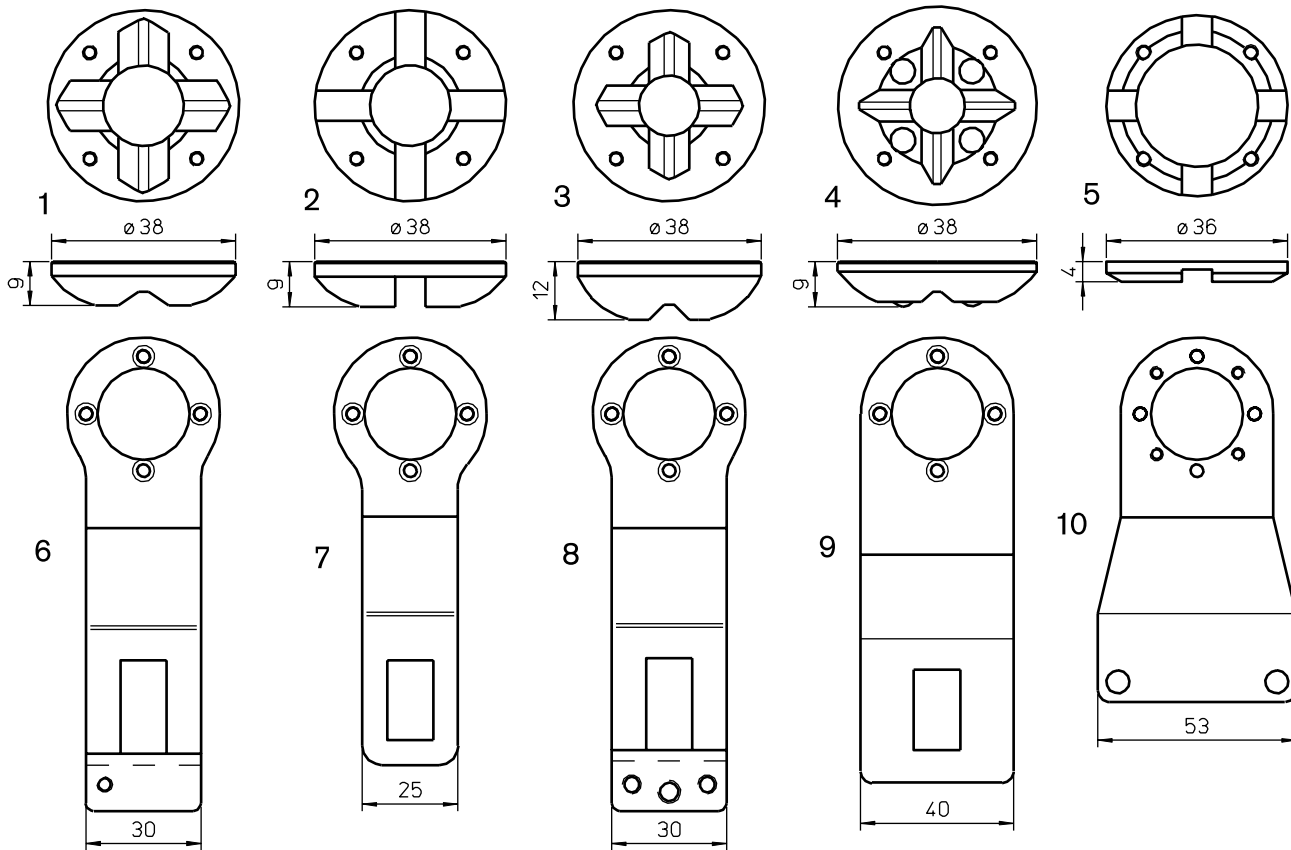
Accessories

	Centricut part number	Reference number	Alternate reference	Description	Pkg qty
1	MZ309-5080	46602350080	AL10	Stylus foot H9 – brass	1
	MZ309-5080CP		AL145	Stylus foot H9 – brass CP	1
	MZ309-1043	46572301043	AL15	Stylus foot H9 – steel	1
	MZ309-1045	46572301045	AL16	Stylus foot H9 – PTFE*	1
2	MZ309-0001		AL132	Stylus foot H9 – brass	1
	MZ309-0001CP		AL146	Stylus foot H9 – brass CP	1
	MZ309-0004		AL133	Stylus foot H9 – steel	1
3	MZ309-1041	46572301041	AL17	Stylus foot H12 – brass	1
	MZ309-1041CP		AL147	Stylus foot H12 – brass CP	1
	MZ309-1042	46572301042	AL59	Stylus foot H12 – steel	1
	MZ309-1041T	46572301041	AL18	Stylus foot H12 – PTFE*	1
4	MZ309-0003		AL39	Stylus foot – H9 brass w/ball bearing	1
5	MZ309-0520	46512300520	AL117	Stylus foot H4 – brass	1
6	MZ309-0005		AL64	Stylus arm w/screw M4	1
	MZ309-0580	36602300580	AL66	Stylus arm w/screw M6	1
7	MZ309-0560	36602300560, 36682300050	AL60	Stylus arm – steel	1
8	MZ309-0281	36682300281	AL167	Stylus arm – steel	1
9	MZ309-0020	36602350020	AL168	Stylus arm – large offset	1
10	MZ309-0250	46522300250	AL169	Stylus arm	1
	MZ309-001 (not shown)			Screws for stylus feet	10

*PolyTetraFluoroEthylene is a fluorocarbon-based polymer and is commonly abbreviated PTFE. The Teflon® brand of PTFE is manufactured only by DuPont and is not sold by Hypertherm. Hypertherm purchases other brands of PTFE from various high quality manufacturers.

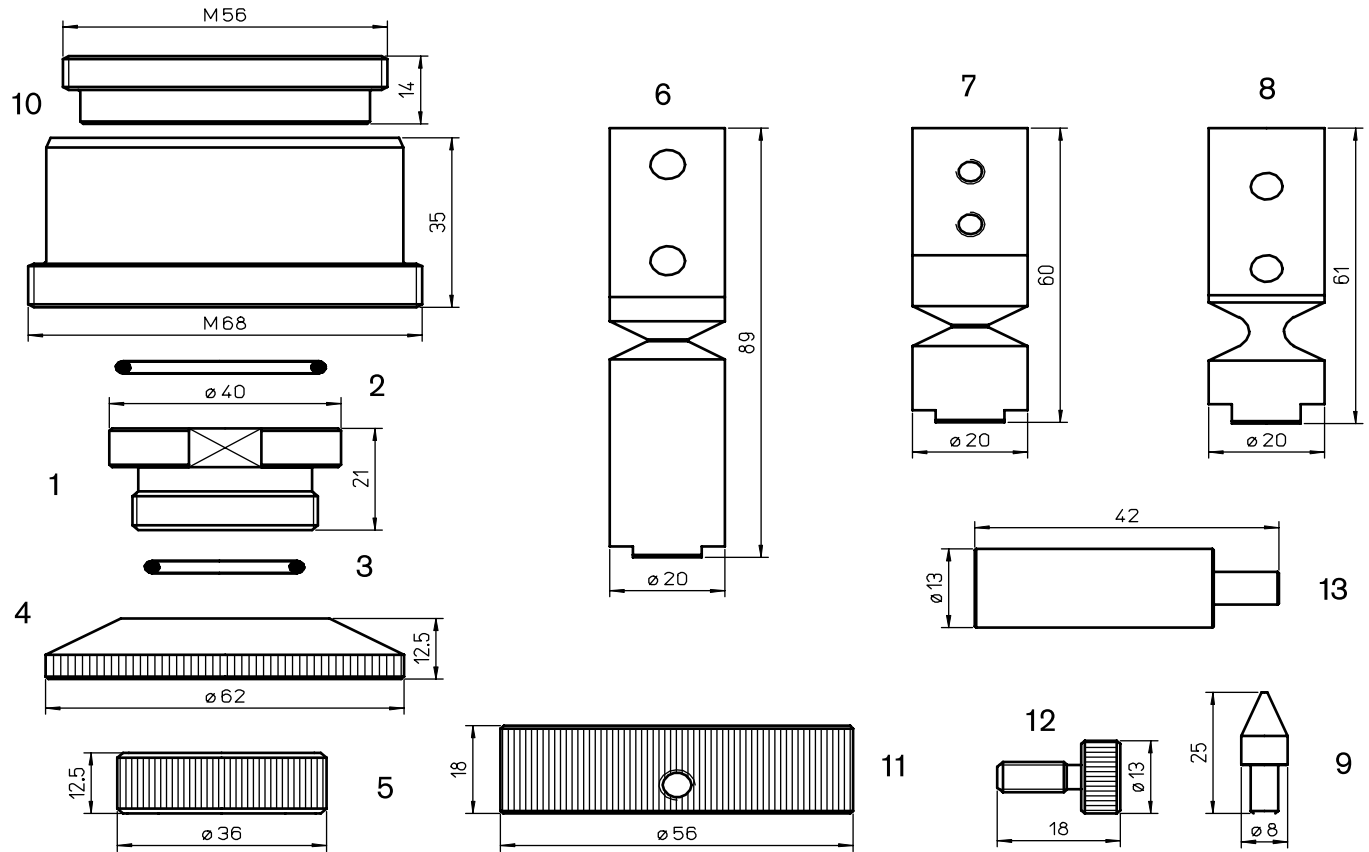

Accessories

	Centricut part number	Reference number	Alternate reference	Description	Pkg qty
1	MZ309-0080	46523300080	AL63	Base	1
2	MZ309-3200	J2600S03200	AL97	O-ring external base (rubber)	1
3	MZ309-2200	J2600S02200	AL98	O-ring internal base	1
4	MZ309-0030	46683300030	AL57	Retainer	1
5	MZ309-1720	46583301720	AL13	Retainer nut	1
6	MZ309-0550	36602300230	AL12	Break-away bar L89-M8	1
7	MZ309-0280	36682300280	AL14	Break-away bar L60-M8 (aluminum)	1
8	MZ309-0101	36572300101	AL121	Break-away bar L61-M6	1
9	MZ309-0013	46600030013	AL20	Table pin	5
10	MZ309-309-1		AL106	Housing for 2.0" lens	1
11	MZ335-0930	46683300930	AL153	Ring	1
	MZ335-0003		AL166	Ring kit - (MZ335-0930 and 4 x MZ335-0320)	1
12	MZ335-0320	46683300032	AL152	Mild steel bolt M5 x 0.5	1
13	MZ335-0008	46522300242	AL186	Stylus pin	1

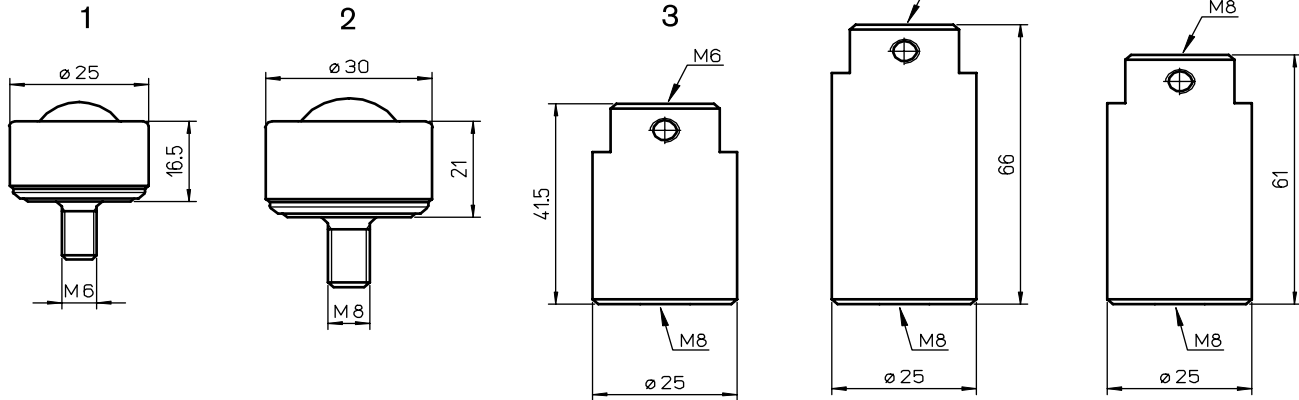

Accessories

	Centricut part number	Reference number	Alternate reference	Description	Pkg qty
1	MZ309-Z580 MZ309-Z580X	Z21KV000580 Z21KV000580	AL61 AL3061	Roller ball - 25 mm - M6 Roller ball - 25 mm - M6 (10 pack)	1 10
2	MZ309-1160	Z21ZZ001160	AL210	Roller ball - 30 mm - M8	1
3	MZ309-0321	46575100321	AL62	Block, stainless steel - 41.5 mm	1
4	MZ309-0050	46705100050	AL134	Block, stainless steel, long - 66 mm	1
5	MZ309-0324		AL324	Block, stainless steel - 61 mm	1

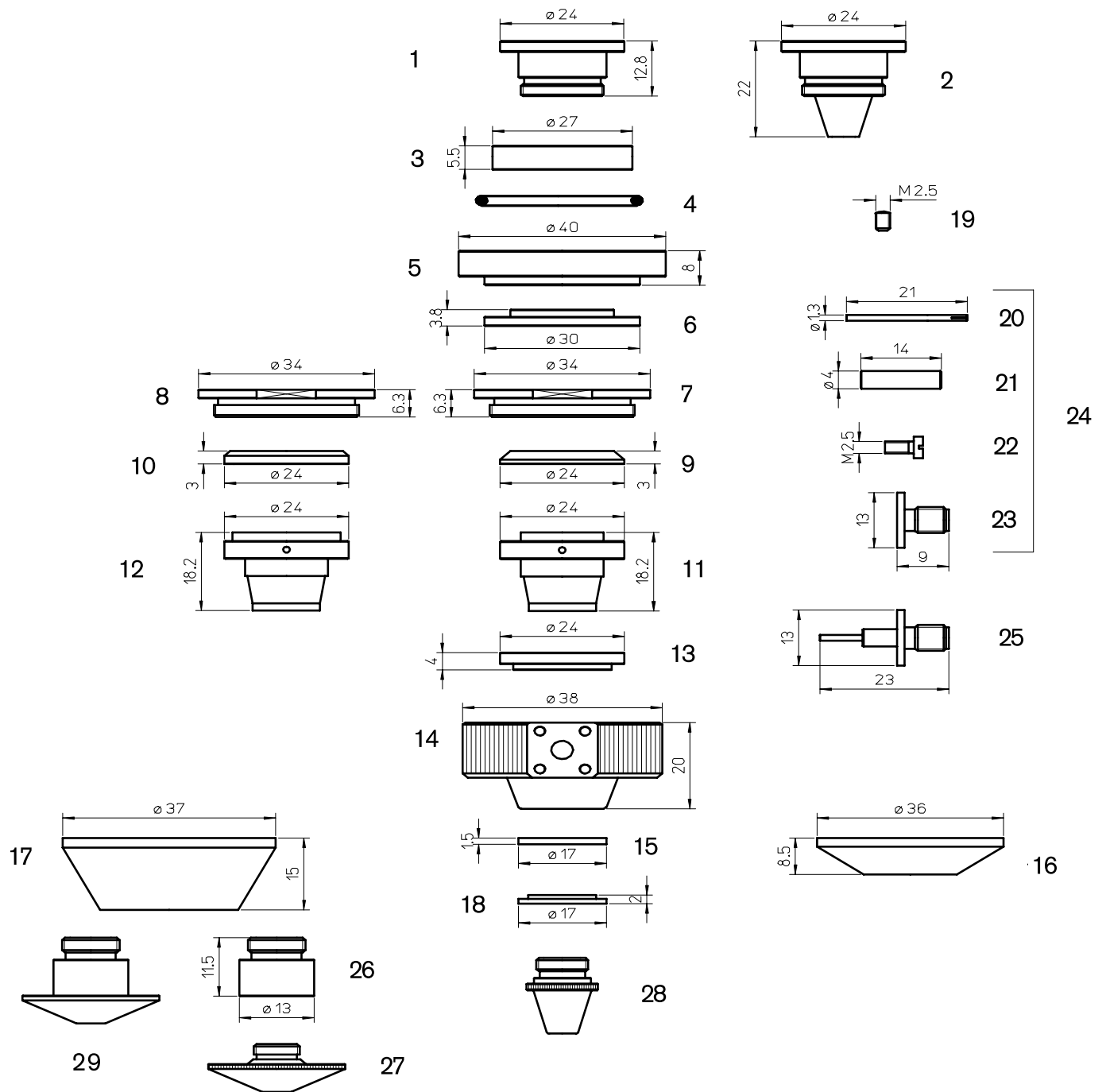

Consumables

	Centricut part number	Reference number	Alternate reference	Description	Pkg qty
1	MZ335-1110	46683301110	AL74	Central copper body	1
2	MZ335-0100	Centricut design	AL112	Central copper body	1
3	MZ335-1080	46683301080	AL80	Spacer - 27x5.5 PTFE*	1
	MZ335-1080P	46683301080	AL80/P	Spacer 27x5.5 - plastic	1
	MZ335-1080C	46683301080	AL280	Spacer 27x5.5 - ceramic	1
	MZ335-1080M	46683301080	ALM280	Spacer 27x5.5 - ceramic	1
4	MZ309-3200	J2600S03200	AL97	O-ring external base - rubber	1
5	MZ335-1070	46683301070	AL84	Base - brass	1

Centricut is a registered trademark of Hypertherm Inc. and may be registered in the United States and/or other countries. All other trademarks are the properties of their respective owners. Centricut is in no way affiliated with Mazak.

Consumables

	Centricut part number	Reference number	Alternate reference	Description	Pkg qty
6	MZ335-1090	46683301090	AL79	Spacer 30x4 - PTFE*	1
	MZ335-0090C	46683301090	AL79/P	Spacer 30x4 - plastic	1
	MZ335-1090C	46683301090	AL279	Spacer 30x4 - ceramic	1
	MZ335-1090M	46683301090	ALM279	Spacer 30x4 - ceramic	1
7	MZ335-1100	46683301100	AL83	Nut - copper	1
8	MZ335-1101	46773300510	AL376	Nut - copper	1
9	MZ335-1120	46683301120	AL77	Spacer 24x3 - PTFE*	1
	MZ335-1120LL	46683301120	AL77/P	Spacer 24x3 - plastic	1
	MZ335-1120C	46683301120	AL277	Spacer 24x3 - ceramic	1
	MZ335-1120M	46683301120	ALM277	Spacer 24x3 - ceramic	1
10	MZ335-0710	46773300710	AL377	Spacer 24x3 - ceramic	1
	MZ335-0710M	46773300710	ALM377	Spacer 24x3 - ceramic	1
11	MZ335-0850	46683300850	AL75	Nozzle holder - copper	1
12	MZ335-0720	46773300720	AL253	Nozzle holder - copper	1
13	MZ335-1130	46683301130	AL78	Spacer 24x4 - PTFE*	1
	MZ335-1130LL	46683301130	AL78/P	Spacer 24x4 - plastic	1
	MZ335-1130C	46683301130	AL278	Spacer 24x4 - ceramic	1
	MZ335-1130M	46683301130	ALM278	Spacer 24x4 - ceramic	1
14	MZ335-1140	46683301140	AL73	Body - aluminum	1
15	MZ335-1150	46683301150	AL81	Spacer 17x1.5 - PTFE*	1
16	MZ335-1930	46683301930	AL111	Protection disk - PTFE*	1
	MZ335-1930LL	46683301930	AL111/P	Protection disk - plastic	1
	MZ335-0009	46683301930	AL275	Protection disk - ceramic	1
17	MZ335-1841	46683301841	AL118	Spacer - PTFE*	1
18	MZ335-1160	46683301160	AL82	Ring 17x2 - copper	1
19	MZ335-1180	46683301180	AL119	Screw for contact	1
20	MZ335-1170	46683301170	AL76	Contact	1
21	MZ335-0030		AL88	Connecting PTFE* pipe	1
22	MZ335-0000	46683300000	AL127	Screw for connectors (4 pcs)	4
23	MZ335-1113		AL113	Connector	1
24	MZ335-0001	46683301170	AL154	Kit connector (AL76,88,127,113)	1
25	MZ335-0001A		AL213	Connector assembly	1
26	MZ335-1830	46683301830	AL128	Adaptor for Trumpf style nozzles	1
27	Please refer to the Trumpf nozzle section				
28	Please refer to the Mazak nozzle section				
29	Please refer to the Mazak nozzle section				

*PolyTetraFluoroEthylene is a fluorocarbon-based polymer and is commonly abbreviated PTFE. The Teflon® brand of PTFE is manufactured only by DuPont and is not sold by Hypertherm. Hypertherm purchases other brands of PTFE from various high quality manufacturers.

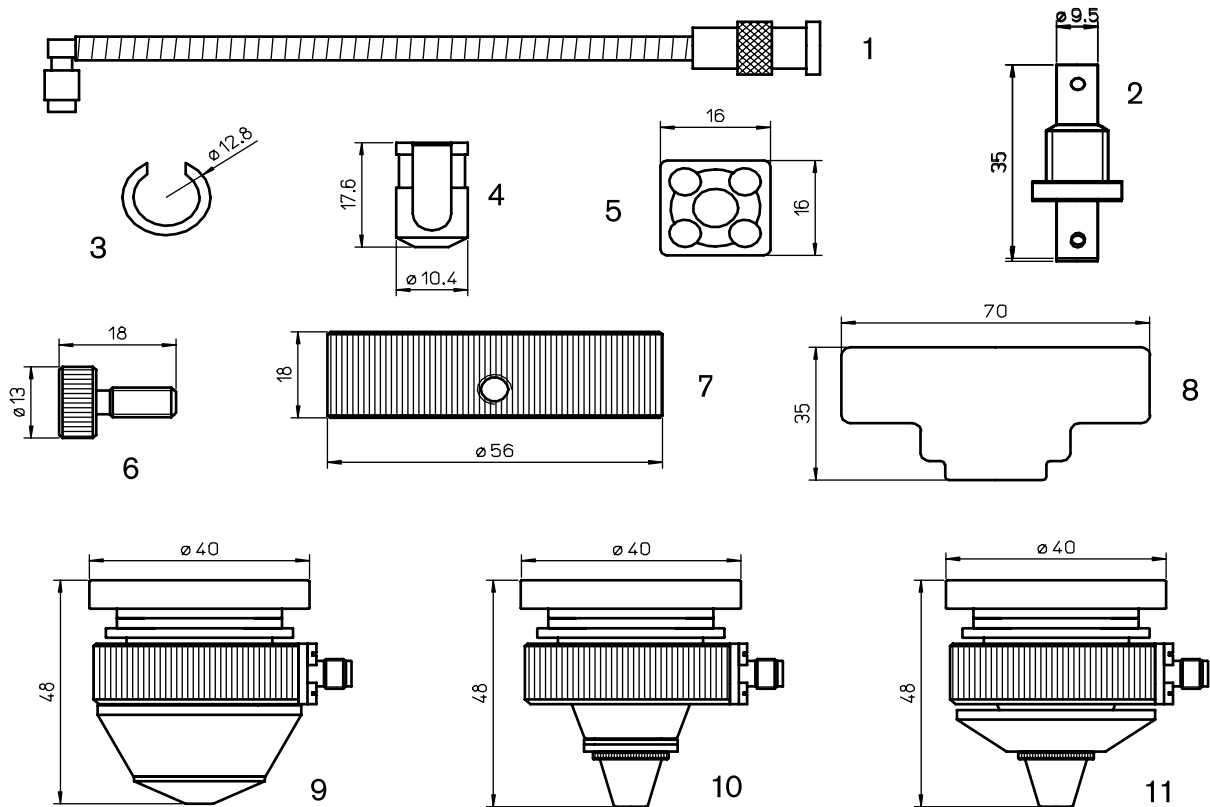

Consumables

	Centricut part number	Reference number	Alternate reference	Description	Pkg qty
1	MZ335-1980	46683301980	AL103	Connecting cable – sensor head (28 cm)	1
	MZ335-1330	46683301330	AL103/S	Connecting cable – sensor head (31 cm)	1
2	MZ335-0005		AL104	Cable adaptor	1
3	MZ335-1870	46683301870	AL155	Cover clips – PTFE*	1
4	MZ335-1860	46683301860	AL156	Cable connector cover – PTFE*	1
	MZ335-1860LL	46683301860	AL156/P	Cable connector cover long life plastic	1
5	MZ335-1850	46683301850	AL157	Connector cover – PTFE*	1
	MZ335-1850P	46683301850	AL157/P	Connector cover long life – plastic	1
6	MZ335-0320	46683300032	AL152	Mild steel bolt M5 X 0.5	1
7	MZ335-0930	46683300930	AL153	Ring	1
	MZ335-0003		AL166	Ring kit (MZ335-0930 and 4 x MZ335-0320)	1
8	MZ335-1230	46683301230	AL165	Plate	1
9	MZ335-0002		TMA10	Head w/PTFE* spacer	1
	MZ335-0012		TMA10/P	Head w/long life spacer	1
	MZ335-1013		TMA10/C	Head w/ceramic spacer	1
10	MZ335-1014		TMA20	Head w/PTFE* spacer	1
	MZ335-0015		TMA20/P	Head w/long life spacer	1
	MZ335-0016		TMA20/C	Head w/ceramic spacer	1
11	MZ335-0017		TMA30	Head w/PTFE* spacer	1
	MZ335-0018		TMA30/P	Head w/long life spacer	1
	MZ335-0019		TMA30/C	Head w/ceramic spacer	1

*PolyTetraFluoroEthylene is a fluorocarbon-based polymer and is commonly abbreviated PTFE. The Teflon® brand of PTFE is manufactured only by DuPont and is not sold by Hypertherm. Hypertherm purchases other brands of PTFE from various high quality manufacturers.

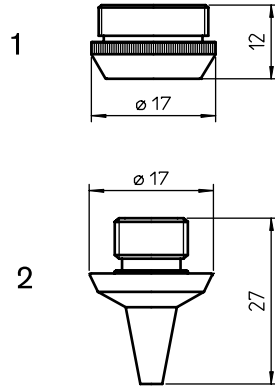
Consumables

	Centricut part number	Reference number	Alternate reference	Description	Pkg qty
1	MZ332-1280	46713331280	AL337	Nut - Vespel®	1
2	MZ332-1305		L1300	Nozzle - 1.0 mm 3D	1
	MZ332-1320	46713331320	L1295	Nozzle - 1.2 mm 3D	1
	MZ332-1310	46713331310	L1296	Nozzle - 1.5 mm 3D	1
	MZ332-1301		L1301	Nozzle - 1.8 mm 3D	1
	MZ332-1300	46713331300	L1297	Nozzle - 2.0 mm 3D	1
	MZ332-1330	46713331330	L1298	Nozzle - 2.5 mm 3D	1
	MZ332-1290	46713331290	L1299	Nozzle - 3.0 mm 3D	1

Mazak® 3D - Precitec® 5"C/MG - 5"H/MG

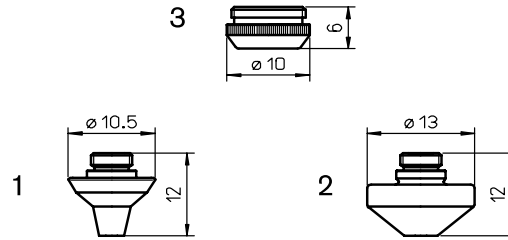

Consumables

	Centricut part number	Reference number	Alternate reference	Description	Pkg qty
1	PT347-0005	46713300290-10	L554	Nozzle - 1.0 mm 3D	1
	PT347-0005X	46713300290-10	L30554	Nozzle - 1.0 mm 3D (10 pack)	10
	PT347-0290-1.2	46713300290-12	L555	Nozzle - 1.2 mm 3D	1
	PT347-0090X	46713300290-12	L30555	Nozzle - 1.2 mm 3D (10 pack)	10
	PT347-0290	46713300290-15, P0352-381-00015	L556	Nozzle - 1.5 mm 3D	1
	PT347-0290X	46713300290-15, P0352-381-00015	L30556	Nozzle - 1.5 mm 3D (10 pack)	10
	PT347-0118		L557	Nozzle - 1.8 mm 3D	1
	PT347-0118X		L30557	Nozzle - 1.8 mm 3D (10 pack)	10
	PT347-0280	46713300310, P0352-382-00020	L558	Nozzle - 2.0 mm 3D	1
	PT347-0280X	46713300310, P0352-382-00020	L30558	Nozzle - 2.0 mm 3D (10 pack)	10
	PT347-0001	46713300280-25	L560	Nozzle - 2.5 mm 3D	1
	PT347-0001X	46713300280-25	L30560	Nozzle - 2.5 mm 3D (10 pack)	10
	PT347-0002	46713300280-30, 46713300430	L563	Nozzle - 3.0 mm 3D	1
	PT347-0002X	46713300280-30	L30563	Nozzle - 3.0 mm 3D (10 pack)	10
	PT347-0035	46713300280-35	L564	Nozzle - 3.5 mm 3D	1
	PT347-0035X	46713300280-35	L30564	Nozzle - 3.5 mm 3D (10 pack)	10
2	PT347-0004		L576	Nozzle - 1.0 mm 2D	1
	PT347-0004X		L30576	Nozzle - 1.0 mm 2D (10 pack)	10
	PT347-0310-1.2	46713300310	L577	Nozzle - 1.2 mm 2D	1
	PT347-0012X	46713300310	L30577	Nozzle - 1.2 mm 2D (10 pack)	10
	PT347-0310	P0352-386-00015	L578	Nozzle - 1.5 mm 2D	1
	PT347-0310X	P0352-386-00015	L30578	Nozzle - 1.5 mm 2D (10 pack)	10
	PT347-1018		L579	Nozzle - 1.8 mm 2D	1
	PT-347-1018X		L30579	Nozzle - 1.8 mm 2D (10 pack)	10
	PT347-0300	46713300300, P0352-387-00020	L580	Nozzle - 2.0 mm 2D	1
	PT347-0300X	46713300300, P0352-387-00020	L30580	Nozzle - 2.0 mm 2D (10 pack)	10
	PT347-0003	46713300300-25	L581	Nozzle - 2.5 mm 2D	1
PT347-0003X	46713300300-25	L30581	Nozzle - 2.5 mm 2D (10 pack)	10	
PT347-0006	46713300300-30	L582	Nozzle - 3.0 mm 2D	1	
PT347-0006X	46713300300-30	L30582	Nozzle - 3.0 mm 2D (10 pack)	10	
3	PT347-0320	46713300321, P0352-311-00001	AL160	Union nut - Vespel®	1

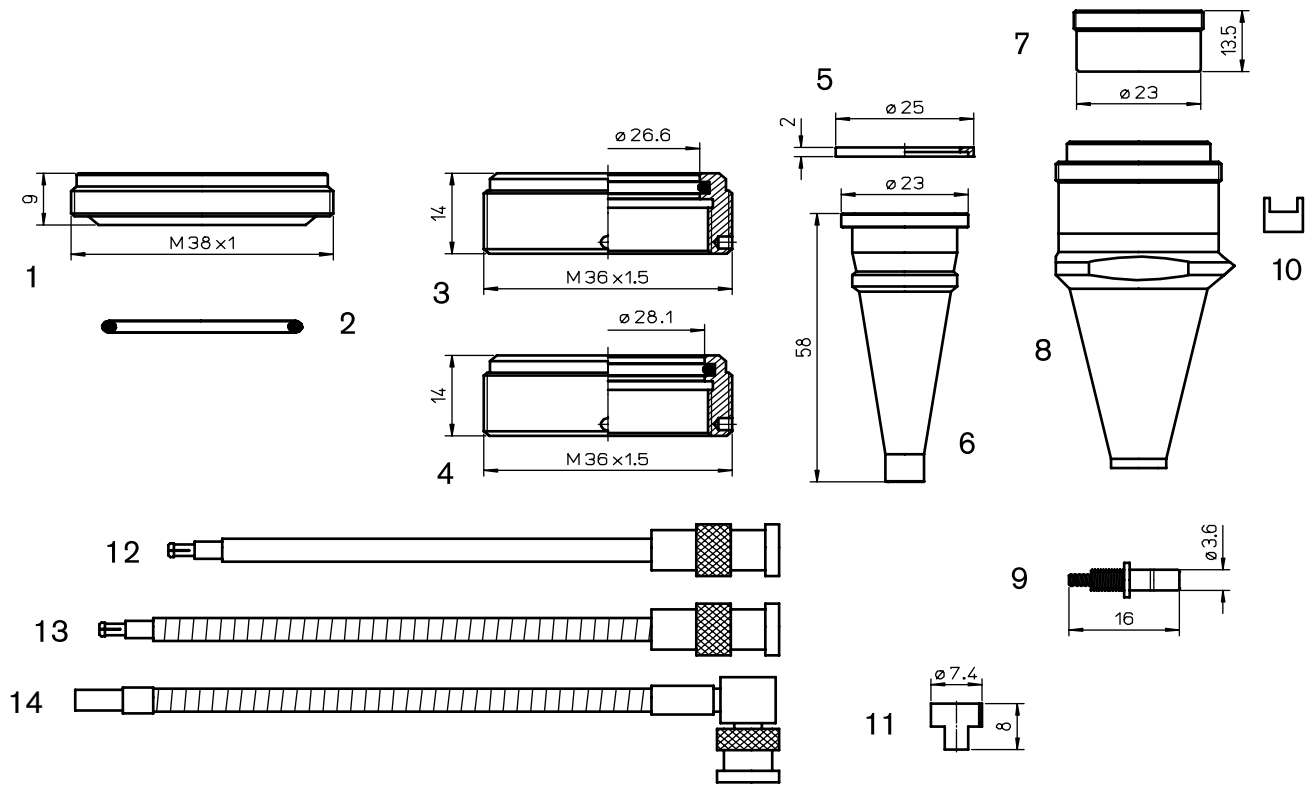

Consumables

	Centricut part number	Reference number	Alternate reference	Description	Pkg qty
1	PT347-4297	P0492-702-00001, 29100021	AL198	Outer body insulating ring	1
2	AM326-6453	71366453	AL94	Outer nozzle o-ring	1
3	PT347-0008	46713330200	AL218	Outer body isolating ring (Precitec)	1
4	PT347-0920	46713330920	AL221	Outer body isolating ring (Mazak)	1
5	PT347-350	46713330960	AL350	Inner cone isolating ring	1
6	PT347-349	46713330930	AL349	Inner sensor cone	1
7	PT347-0940	46713330940	AL353	Retaining ring	1
8	PT347-1240	46713331240	AL351	Torch outer body	1
9	PT347-1111	46713331111	AL354	Connector w/spring	1
10	PT347-0951 NEW	46713330951	AL356	Connector cup	1
11	PT347-0009		AL256	Connector protector	1
12	PT347-0101	P0360-100-00500, 46713300100	AL204	Sensor cable 500 mm (OEM)	1
13	PT347-1386	281386, P0360-155-00500	AL257	Sensor cable - armored	1
14	PT347-0181	46743300181	AL358	Sensor cable 305 mm - armored (12')	1
	PT347-9006 (not shown)	HNP-006		Connector cup - HNP	1
	PT347-3323 (not shown)	567123323A1		Nozzle body HNPZ	1



Consumables

	Centricut part number	Reference number	Alternate reference	Description	Pkg qty
1	PT347-1005	281005, P0352-323-00010	L480	Nozzle - 1.0 mm ZK	1
	PT347-1005X	281005, P0352-323-00010	L30480	Nozzle - 1.0 mm ZK (10 pack)	10
	PT347-1034	281034, P0352-324-00012	L481	Nozzle - 1.2 mm ZK	1
	PT347-1034X	281034, P0352-324-00012	L30481	Nozzle - 1.2 mm ZK (10 pack)	10
	PT347-1013	281013, P0352-325-00015	L482	Nozzle - 1.5 mm ZK	1
	PT347-1013X	281013, P0352-325-00015	L30482	Nozzle - 1.5 mm ZK (10 pack)	10
	PT347-0899	280899, P0352-326-00018	L483	Nozzle - 1.8 mm ZK	1
	PT347-0899X	280899, P0352-326-00018	L30483	Nozzle - 1.8 mm ZK (10 pack)	10
	PT347-0044-3	350044.3, P0352-327-00020	L484	Nozzle - 2.0 mm ZK	1
	PT347-0044X	350044.3, P0352-327-00020	L30484	Nozzle - 2.0 mm ZK (10 pack)	10
	PT347-1025	P0352-328-00025	L485	Nozzle - 2.5 mm ZK	1
	PT347-1025X	350044.3, P0352-328-00025	L30485	Nozzle - 2.5 mm ZK (10 pack)	10
2	PT347-1006	281006, P0352-333-00010	L486	Nozzle - 1.0 mm KK	1
	PT347-1006X	281006, P0352-333-00010	L30486	Nozzle - 1.0 mm KK (10 pack)	10
	PT347-1030	281030, P0352-334-00012	L487	Nozzle - 1.2 mm KK	1
	PT347-1030X	281030, P0352-334-00012	L30487	Nozzle - 1.2 mm KK (10 pack)	10
	PT347-1031	281031, P0352-335-00015	L488	Nozzle - 1.5 mm KK	1
	PT347-1031X	281031, P0352-335-00015	L30488	Nozzle - 1.5 mm KK (10 pack)	10
	PT347-0898	280898, P0352-336-00018	L489	Nozzle - 1.8 mm KK	1
	PT347-0898X	280898, P0352-336-00018	L30489	Nozzle - 1.8 mm KK (10 pack)	10
	PT347-1020	P0352-336-00020	L490	Nozzle - 2.0 mm KK	1
	PT347-1020X	P0352-336-00020	L30490	Nozzle - 2.0 mm KK (10 pack)	10

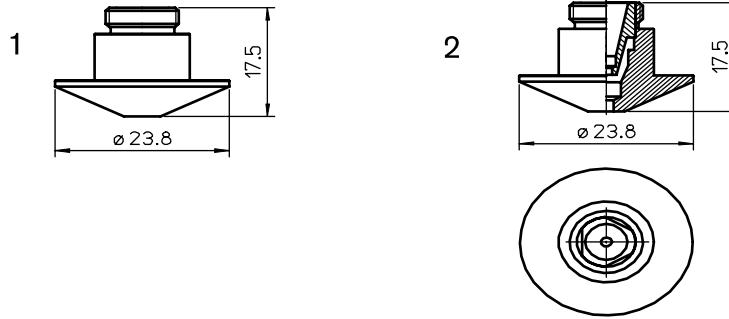

Consumables

	Centricut part number	Reference number	Alternate reference	Description	Pkg qty
1	MZ335-0004		L428	Nozzle - 1.0 mm	1
	MZ335-0011		L423	Nozzle - 1.2 mm	1
	MZ335-1950	46683301950	L429	Nozzle - 1.5 mm	1
	MZ335-1821	46683301821	L430	Nozzle - 2.0 mm	1
	MZ335-0112		L471	Nozzle - 2.2 mm	1
	MZ335-1960	46683301960	L431	Nozzle - 2.5 mm	1
	MZ335-1970	46683301970	L432	Nozzle - 3.0 mm	1
	MZ335-0006		L472	Nozzle - 3.5 mm	1
	MZ335-0013		L473	Nozzle - 4.0 mm	1
	MZ335-0014		L474	Nozzle - 4.5 mm	1
	MZ335-0004CP		L428X	Nozzle - 1.0 mm CP	1
	MZ335-0007CP		L423X	Nozzle - 1.2 mm CP	1
	MZ335-1950CP	46683301950	L429X	Nozzle - 1.5 mm CP	1
	MZ335-1821CP	46683301821	L430X	Nozzle - 2.0 mm CP	1
	MZ335-0012CP		L471X	Nozzle - 2.2 mm CP	1
	MZ335-1960CP	46683301960	L431X	Nozzle - 2.5 mm CP	1
	MZ335-1970CP	46683301970	L432X	Nozzle - 3.0 mm CP	1
	MZ335-0006CP		L472X	Nozzle - 3.5 mm CP	1
MZ335-0013CP		L473X	Nozzle - 4.0 mm CP	1	
MZ335-0014CP		L474X	Nozzle - 4.5 mm CP	1	
2	MZ360-0001	Centricut design	L850	Nozzle - 1.0 mm double	1
	MZ360-0002	Centricut design	L851	Nozzle - 1.2 mm double	1
	MZ360-0003	Centricut design	L852	Nozzle - 1.5 mm double	1
	MZ360-0004	Centricut design	L858	Nozzle - 1.8 mm double	1
	MZ360-0005	Centricut design	L853	Nozzle - 2.0 mm double	1
	MZ360-0006	Centricut design	L849	Nozzle - 2.2 mm double	1
	MZ360-0007	Centricut design	L854	Nozzle - 2.5 mm double	1
	MZ360-0008	Centricut design	L855	Nozzle - 3.0 mm double	1
	MZ360-0009	Centricut design	L856	Nozzle - 3.5 mm double	1
	MZ360-0001CP	Centricut design	L850X	Nozzle - 1.0 mm double CP	1
	MZ360-0002CP	Centricut design	L851X	Nozzle - 1.2 mm double CP	1
	MZ360-0003CP	46683302420	L852X	Nozzle - 1.5 mm double CP	1
	MZ360-0004CP	Centricut design	L858X	Nozzle - 1.8 mm double CP	1
	MZ360-0005CP	46683302430	L853X	Nozzle - 2.0 mm double CP	1
	MZ360-0006CP	Centricut design	L849X	Nozzle - 2.2 mm double CP	1
	MZ360-0007CP	46683302440	L854X	Nozzle - 2.5 mm double CP	1
	MZ360-0008CP	46683302450	L855X	Nozzle - 3.0 mm double CP	1
	MZ360-0009CP	Centricut design	L856X	Nozzle - 3.5 mm double CP	1

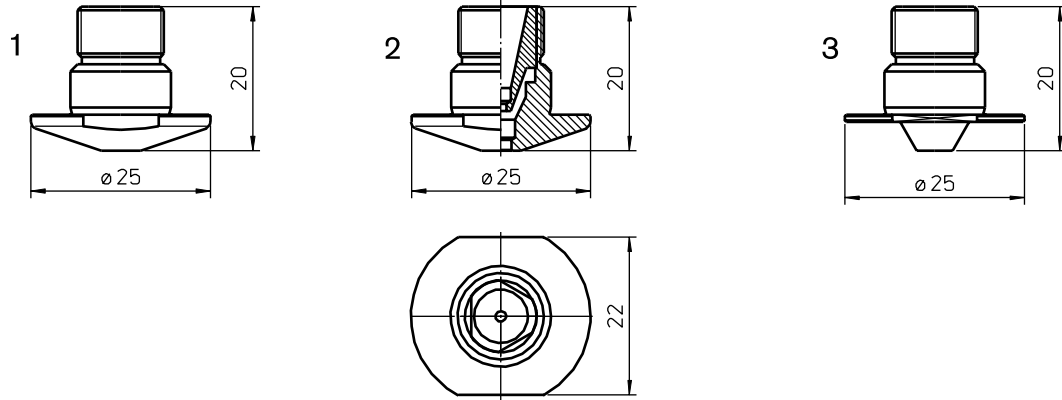

Consumables

	Centricut part number	Reference number	Alternate reference	Description	Pkg qty
1	MZ368-0018CP		L949X	Nozzle - 0.8 mm CP	1
	MZ368-4430CP		L941X	Nozzle - 1.0 mm CP	1
	MZ368-4470CP	46143304470	L942X	Nozzle - 1.2 mm CP	1
	MZ368-4450CP	46143304450	L943X	Nozzle - 1.5 mm CP	1
	MZ368-4455CP		L950X	Nozzle - 1.8 mm CP	1
	MZ368-4460CP	46143304460	L944X	Nozzle - 2.0 mm CP	1
	MZ368-4480CP	46143304480	L945X	Nozzle - 2.5 mm CP	1
	MZ368-4490CP	46143304490	L946X	Nozzle - 3.0 mm CP	1
	MZ368-4500CP	46143304500	L947X	Nozzle - 3.5 mm CP	1
	MZ368-4510CP	46143304510	L948X	Nozzle - 4.0 mm CP	1
2	MZ373-0001		L952X	Nozzle - 1.2 mm double CP	1
	MZ368-0005CP		L953X	Nozzle - 1.5 mm double CP	1
	MZ373-0003		L954X	Nozzle - 2.0 mm double CP	1
	MZ373-0004		L955X	Nozzle - 2.5 mm double CP	1
	MZ373-0005		L956X	Nozzle - 3.0 mm double CP	1
	MZ373-0006		L957X	Nozzle - 3.5 mm double CP	1
	MZ373-0007		L958X	Nozzle - 4.0 mm double CP	1
	3	MZ427-0001		L1264	Nozzle - 1.0 mm
MZ427-0002			L1265	Nozzle - 1.2 mm	1
MZ427-0003			L1266	Nozzle - 1.5 mm	1
MZ427-0004			L1267	Nozzle - 2.0 mm	1
MZ427-0005			L1268	Nozzle - 3.0 mm	1

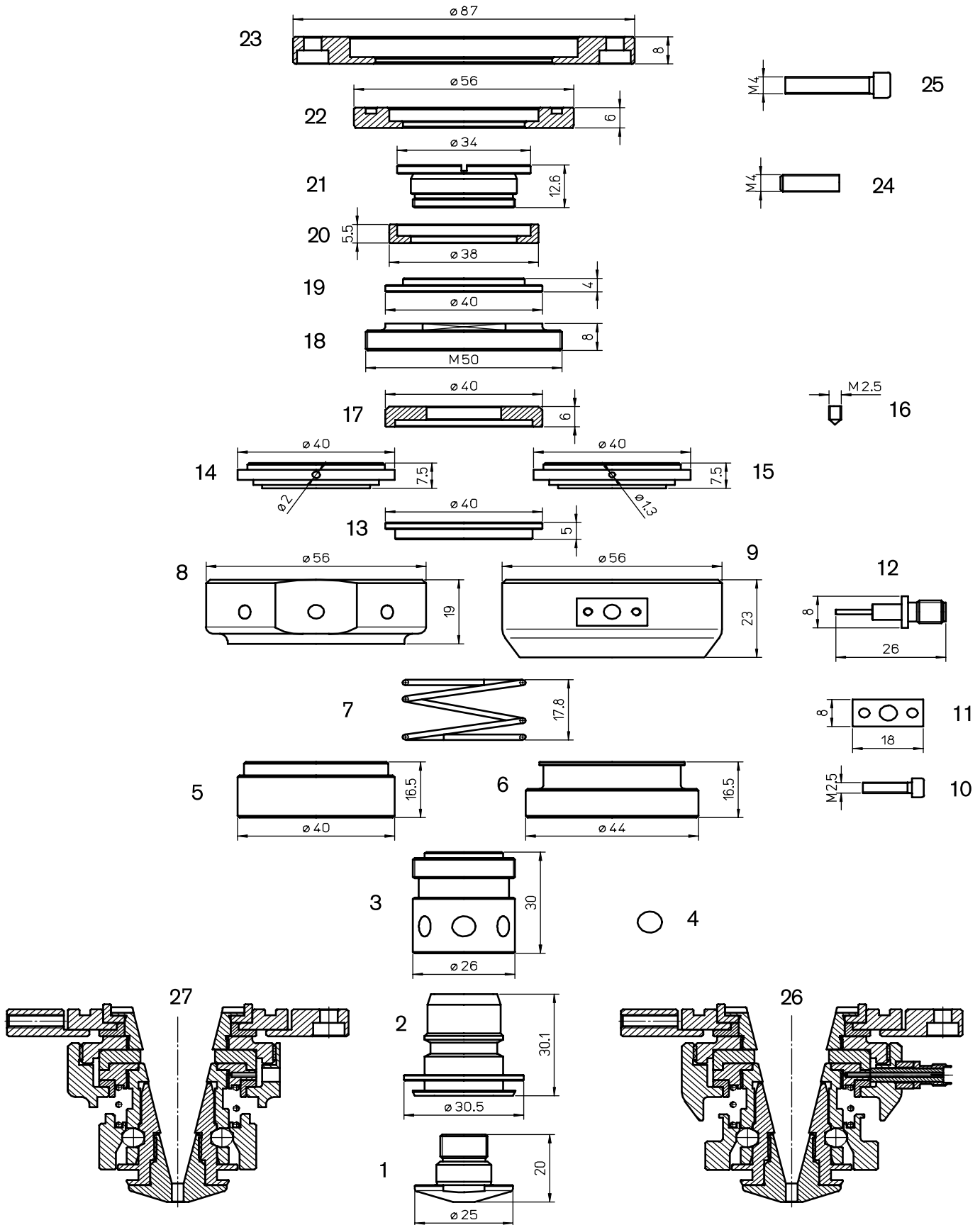

Consumables

	Centricut part number	Reference number	Alternate reference	Description	Pkg qty
1	Please refer to the Mazak® nozzle section				
2	MZ368-0001	36143304420	AL242	Nozzle holder Hyper Gear	1
3	MZ413-4400	36143304400	AL291	Coupler	1
4	MZ413-0230	46143300230	AL311	Replacement ball kit (6 pcs)	1
5	MZ413-4430	46143304430	AL292	Spring retainer	1
6	MZ413-8000	46143308000	AL314	Spring retainer – steel	1
7	MZ413-0220	46143300220	AL289	Spring	1
8	MZ413-3242	36143303242	AL293	Body	1
9	MZ413-7980	36143307980	AL313	Aluminium body	1
10	MZ413-0030	46603300030	AL317	Screw	1
11	MZ413-8170	46143308170	AL318	Spacer	1
12	MZ413-8190	46143308190	AL315	Connector	1
13	MZ408-0240	46143300240	AL284	Insulator – ceramic	1
	MZ413-0240	46143300240	AL384	Insulator – PTFE*	1
14	MZ413-4250	46143304250	AL287	Retainer nut	1
15	MZ413-7420	46143307420	AL295	Retainer nut	1
16	MZ413-1180	46683301180	AL322	Screw	1
17	MZ408-4440	46143304440	AL290	Insulator – ceramic	1
	MZ413-4440	46143304440	AL390	Insulator – PTFE*	1
18	MZ413-0290	46143300290	AL294	Retainer nut	1
19	MZ408-0260	46143300260	AL285	Insulator – ceramic	1
	MZ413-0260	46143300260	AL385	Insulator – PTFE*	1
20	MZ408-0270	46143300270	AL286	Insulator – ceramic	1
	MZ413-0270	46143300270	AL386	Insulator – PTFE*	1
21	MZ413-0280	46143300280	AL288	Retainer nut	1
22	MZ413-0320	46143300320	AL316	Ring – brass	1
23	MZ413-0332	36143300332	AL320	Ring – aluminum	1
24	MZ413-0010		AL321	Screw (4 pcs)	1
25	MZ413-0200	A06CB040200	AL319	Set screw (4 pcs)	1
26	MZ413-0001		TMA50/C	Complete head (ceramic spacer)	1
27	MZ413-0002		TMA40/C	Complete head (ceramic spacer)	1

*PolyTetraFluoroEthylene is a fluorocarbon-based polymer and is commonly abbreviated PTFE. The Teflon® brand of PTFE is manufactured only by DuPont and is not sold by Hypertherm. Hypertherm purchases other brands of PTFE from various high quality manufacturers.

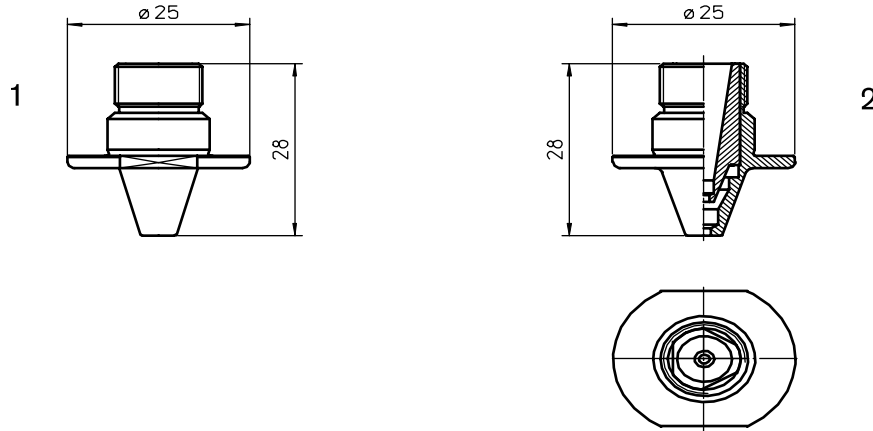

Consumables

	Centricut part number	Reference number	Alternate reference	Description	Pkg qty
1	MZ373-0308CP		L1379X	Nozzle - 0.8 mm slim CP	1
	MZ373-0310CP		L1380X	Nozzle - 1.0 mm slim CP	1
	MZ373-0341CP	46143310341	L1381X	Nozzle - 1.2 mm slim CP	1
	MZ373-0351CP	46143310351	L1382X	Nozzle - 1.5 mm slim CP	1
	MZ373-0318CP		L1389X	Nozzle - 1.8 mm slim CP	1
	MZ373-0361CP	46143310361	L1383X	Nozzle - 2.0 mm slim CP	1
	MZ373-0365CP		L1388X	Nozzle - 2.2 mm slim CP	1
	MZ373-0371CP	46143310371	L1384X	Nozzle - 2.5 mm slim CP	1
	MZ373-0381CP	46143310381	L1385X	Nozzle - 3.0 mm slim CP	1
	MZ373-0391CP	46143310391	L1386X	Nozzle - 3.5 mm slim CP	1
MZ373-0401CP	46143310401	L1387X	Nozzle - 4.0 mm slim CP	1	
2	MZ373-0300CP		L1390X	Nozzle - 0.8 mm slim double CP	1
	MZ373-0311CP		L1391X	Nozzle - 1.0 mm slim double CP	1
	MZ373-0312CP		L1399X	Nozzle - 1.2 mm slim double CP	1
	MZ373-0315CP	36143311500	L1392X	Nozzle - 1.5 mm slim double CP	1
	MZ373-0319CP		L1400X	Nozzle - 1.8 mm slim double CP	1
	MZ373-0320CP	36143311510	L1393X	Nozzle - 2.0 mm slim double CP	1
	MZ373-0322CP		L1398X	Nozzle - 2.2 mm slim double CP	1
	MZ373-0325CP	36143311520	L1394X	Nozzle - 2.5 mm slim double CP	1
	MZ373-0330CP	36143311530	L1395X	Nozzle - 3.0 mm slim double CP	1
	MZ373-0335CP		L1396X	Nozzle - 3.5 mm slim double CP	1

HyperGear – PFP torch

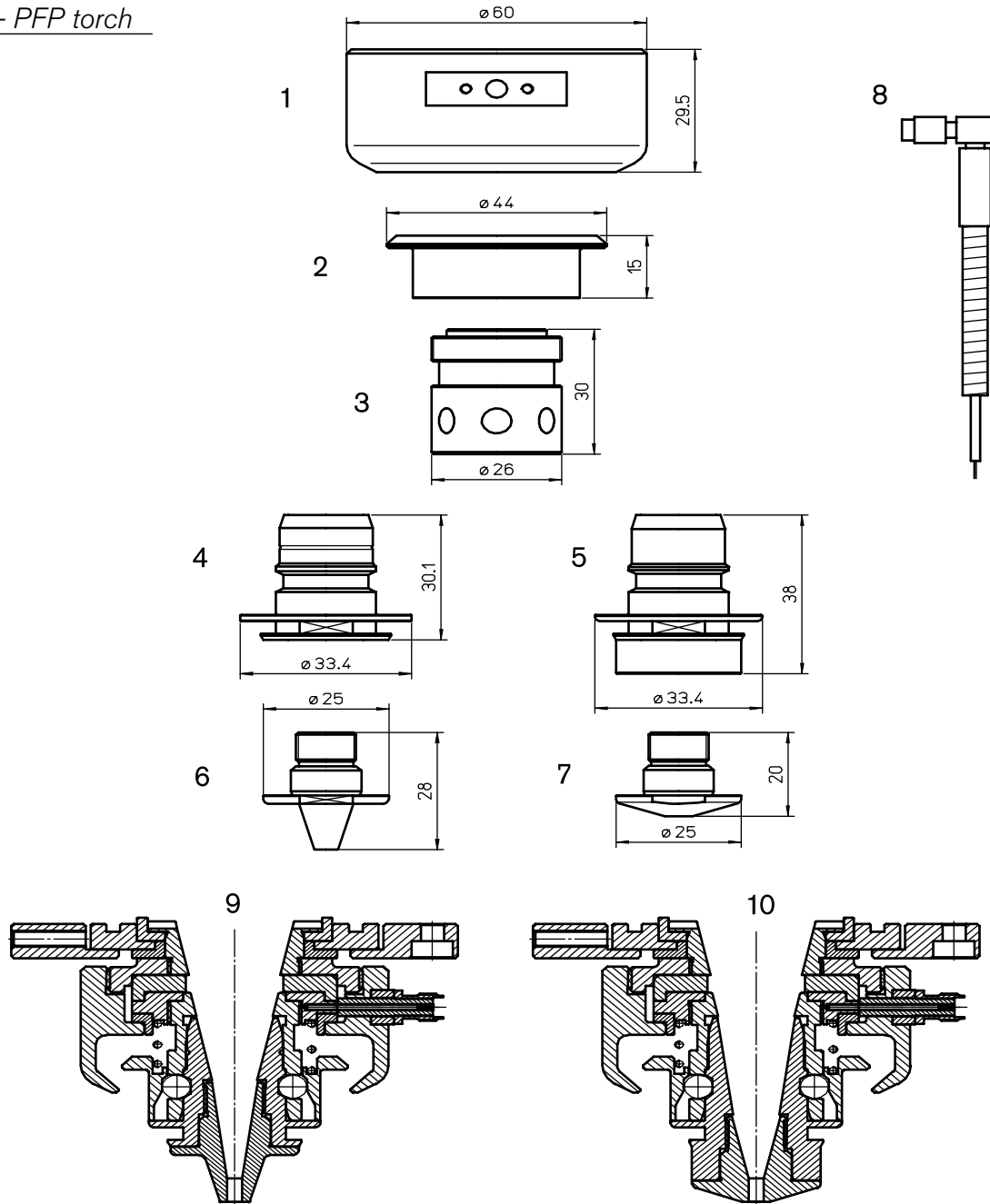

Consumables

	Centricut part number	Reference number	Alternate reference	Description	Pkg qty
1	MZ368-0550	36143310550	AL365	Aluminum body	1
2	MZ368-0541	36143310541	AL366	Retainer spring – steel	1
3	MZ368-0530	36143310530	AL367	Coupler	1
4	MZ368-0522	36143310522	AL362	Nozzle holder large	1
5	MZ368-0740	36143310740	AL363	Nozzle holder long	1
6	Please refer to the Mazak® Slim nozzle section				
7	Please refer to the Mazak® nozzle section				
8	MZ335-8290	46143308290	AL368	Sensor cable – 75 mm	1
9	MZ368-0060	TMA60/C		Head w/ceramic spacer	1
10	MZ368-0070	TMA70/C		Head w/ceramic spacer	1

Centricut is a registered trademark of Hypertherm Inc. and may be registered in the United States and/or other countries. All other trademarks are the properties of their respective owners. Centricut is in no way affiliated with Mazak.

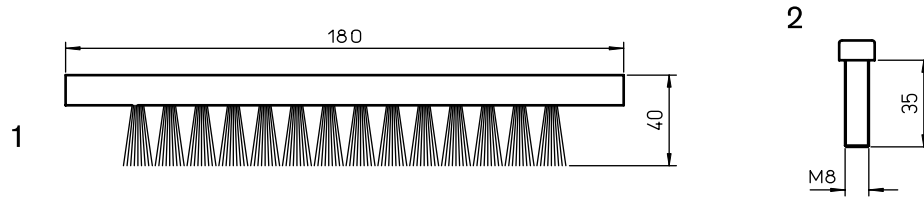

Accessories

	Centricut part number	Reference number	Alternate reference	Description	Pkg qty
1	MZ427-0006		AL301	Brush - w/screws 180x30x20	1
2	BY328-3884	333884	333884	Plastic screws (2 pcs)	2
	AM313-2023 (not shown)	71232023	71232023	Filter - vacuum pump	1

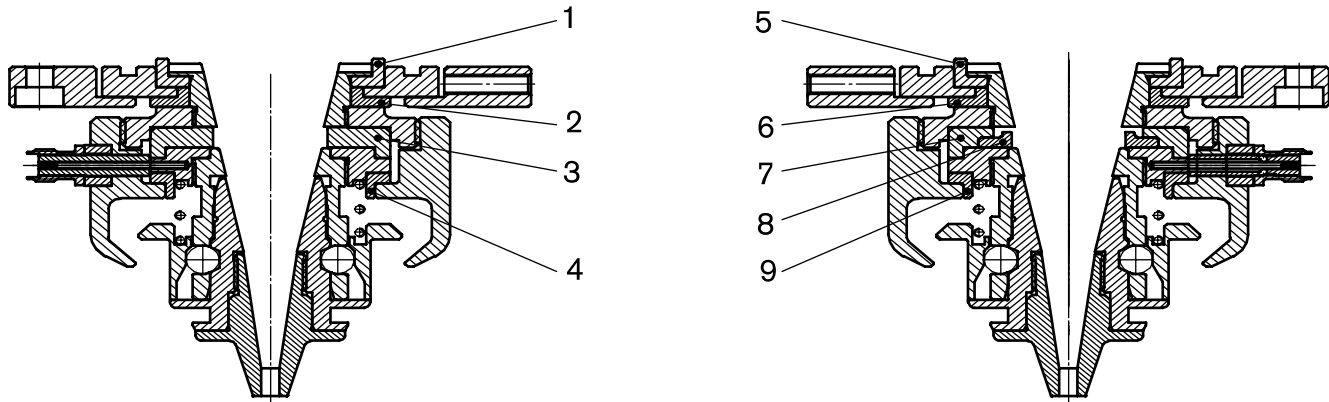

Consumables

	Centricut part number	Reference number	Alternate reference	Description	Pkg qty
1	MZ408-0270	46143300270	AL286	H.G. Insulator ceramic 38 x 5.5	1
	MZ413-0270	46143300270	AL386	H.G. PTFE* insulator 38 x 5.5	1
2	MZ408-0260	46143300260	AL285	H.G. Ceramic insulator 40 x 4	1
	MZ413-0260	46143300260	AL385	H.G. PTFE* insulator 40 x 4	1
3	MZ408-4440	46143304440	AL290	H.G. Insulator ceramic 40 x 6	1
	MZ413-4440	46143304440	AL390	PTFE* insulator 40 x 6	1
4	MZ408-0240	46143300240	AL284	Ceramic insulator 40 x 5	1
	MZ413-0240	46143300240	AL384	H.G. PTFE* insulator 40 x 5	1
5	MZ368-2100 NEW	46143312100	AL486	Insulating ring PPS 38 x 5.5	1
6	MZ368-2130 NEW	46143312130	AL485	Insulating ring PPS 40 x 4	1
7	MZ368-2080 NEW	46143312080	AL490	Spacer PPS 40 x 6	1
8	MZ368-2090 NEW	46143312090	AL487	Ceramic ring 30 x 3	1
9	MZ368-2120 NEW	46143312120	AL484	Insulating ring PPS 40 x 5	1

*PolyTetraFluoroEthylene is a fluorocarbon-based polymer and is commonly abbreviated PTFE. The Teflon® brand of PTFE is manufactured only by DuPont and is not sold by Hypertherm. Hypertherm purchases other brands of PTFE from various high quality manufacturers.

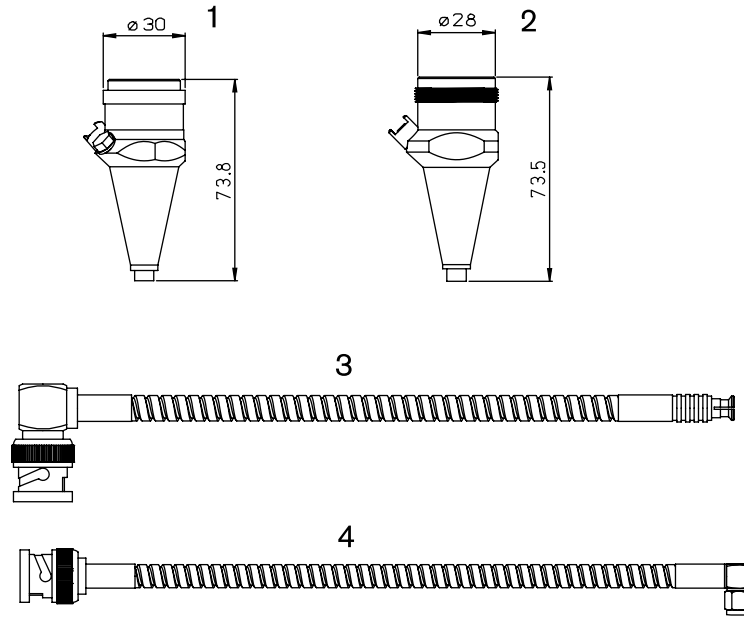
Consumables

	Centricut part number	Reference number	Alternate reference	Description	Pkg qty
1	PT999-HNZ	56743300500		Sensor repair HNZ	1
2	MZ999-HNPZ (HNP)	567123323A1		Sensor repair HNP	1
3	MZ335-1330A	46683301330		Sensor cable – armored 305 mm (12")	1
	MZ335-1980A	46683301980		Sensor cable – armored 280 mm (11")	1
4	MZ335-0111A	46743300111		Sensor cable – armored 280 mm (11")	1
	MZ335-0181A	46743300181		Sensor cable – armored 317.5 mm (12.5")	1
	MZ335-630A (not shown)			Sensor cable – armored 630 mm (25")	

Sensor repairs available in select regions only.

Optics

Centricut part number	Reference number	Type	Diameter	Focal length	Edge thickness
Lenses					
MZ315-0130	Z50MB000130	PLX	1.5"	5.0"	.118"
MZ315-0160	Z50MB000160	PLX	1.5"	5.0"	.236"
MZ315-0400	Z50MB000400	PLX	1.5"	5.0"	.300"
MZ315-2155 NEW	702155	PLX	1.5"	9.5"	.1575"
MZ315-5980	145980	PLX	2.0"	5.0"	.300"
MZ315-5160	Z50Z005160	PLX	2.0"	5.0"	.310"
MZ315-0516A	Z50Z005160A	PLX	2.0"	5.0"	.380"
MZ315-0520A	Z50Z00520A	PLX	2.0"	7.5"	.380"
MZ315-0480 NEW	Z50Z010480	PLX	2.0"	12M	.236"
MZ315-8148	938148	PLX	2.5"	7.5"	.380"
Ultra low absorption lenses					
MZ315-0160MP5	Z50MB000160	PLX	1.5"	5.0"	.236"
MZ315-0400MP5	Z50MB000400	PLX	1.5"	5.0"	.300"
MZ315-0520AMP5	Z50Z00520A	PLX	2.0"	7.5"	.380"

Centricut part number	Reference number	Material	Diameter	Edge thickness	S1
Phase shift mirrors					
MZ315-0040	Z50MB000040	CU	1.5"	.250"	
MZ315-0686	390686	CU	1.5"	.250"	
MZ315-0860	Z50Z010860	CU	2.0"	.375"	
MZ315-7694 NEW	467694	CU	2.0"	.378"	90 degree
Absorbing thin film reflectors (ATFR)					
MZ315-8360	Z50Z008360	ATFR	CU	2.0"	.375"

Centricut part number	Reference number	Type	Material	Diameter	Edge thickness	S1/Reflectivity
Zero phase shift mirrors and total reflectors						
MZ315-0017	Z50MB000030	TRZ	CU	1.575"	.295"	45 degree
MZ315-3055	593055	TRZ	CU	2.36"	.374"	
MZ315-0602	355377	TRZ	CU	2.36"	.394"	
MZ315-0060	Z50MB000060	TRZ	CU	2.36"	.394"	
MZ315-8401	4L104184-01	TRZ	SI	1.75"	.375"	
MZ315-8690	Z50MB008690	TRZ	SI	1.75"	.375"	
MZ315-8825	408825	MMR	SI	2.0"	.200"	
MZ315-0070	Z50MB000070	ZPS	CU	2.0"	.394"	

Centricut part number	Reference number	Material	Diameter	Edge thickness	S1/Reflectivity	S2
Output couplers						
MZ315-8570	Z50MB008670	ZNSE	1.1"	.220"	10MCC-60%	7.5MCX
MZ315-8510	Z50MB008510	ZNSE	1.1"	.220"	15MCC-65%	
MZ315-0560 NEW	911682, Z50MBB010560	ZNSE	1.1"	.220"	20MCC-75%	15MCX
MZ315-0014	BRAL0014	ZNSE	1.1"	.220"	20MCC-40%	15MCX
MZ315-6662	796662	ZNSE	1.1"	.220"	20MCC-50%	15MCX
MZ315-0008	BRAL0008	ZNSE	1.1"	.220"	20MCC-50%	
MZ315-5420	Z50MB005420	ZNSE	1.1"	.220"	20MCC-50%	15MCX
MZ315-0007	BRAL0007	ZNSE	1.1"	.220"	20MCC-70%	20MCX

Centricut part number	Reference number	Material	Diameter	Edge thickness	S1/Reflectivity	
Beam splitters						
MZ315-1727	NEW 931727	ZNSE	1.5"	.120"	50%I-POL	
MZ315-1053	NEW 381053	ZNSE	1.5"	.120"	50%P-POL	
MZ315-7751	NEW 617751	ZNSE	1.5"	.120"	50%S-POL	

Centricut part number	Reference number	Material	Diameter	Focal length	Edge thickness	S2
Collimating optics						
MZ315-8393	448393	ZNSE	1.5"	15.0M	.157"	
MZ315-5433	945433	ZNSE	1.5"	590.55"	.119"	

Centricut part number	Reference number	Material	Diameter	Edge thickness	S1/Reflectivity	S2
Rear mirrors						
MZ315-8100	328100	GE	1.1"	.220"	10MCC	6MCX
MZ315-8500		GE	1.1"	.220"	15MCC-99.5%	
MZ315-0002	BRAL0002	GE	1.1"	.220"	20MCC-99.5%	
MZ315-1407	61407, 326453	GE	1.1"	.220"	20MCC-99.5%	
MZ315-0580	Z50MB010580	GE	1.1"	.220"	99.6%	

Optics care

Centricut part number	Reference number	Description	Pkg qty
TR300-6452	N/A	Lens cleaning paper, Tiffen - 50 piece	1
AM313-SC50	NEW SC50	Lens cleaning paper, Tresor - 50 piece	1
TR300-1115		Lens cleaning pre-cut cotton - 80 piece	1
TR300-SC20		Cotton swab - 20 piece	1
TR300-1010	AL1010	Dropper, lens cleaning fluid	1
TR300-255	AL255	Loupe, magnifying	1
TR300-271	AL271	Base, lens maintenance	1
TR300-7388	787388	Mirror polish (250 ml)	1
AM313-1260	NEW 351260-009	Lens Polarizing Filter - 1.5"	1
AM313-1280	NEW 351280-009	Lens Polarizing Filter - 2.0"	1

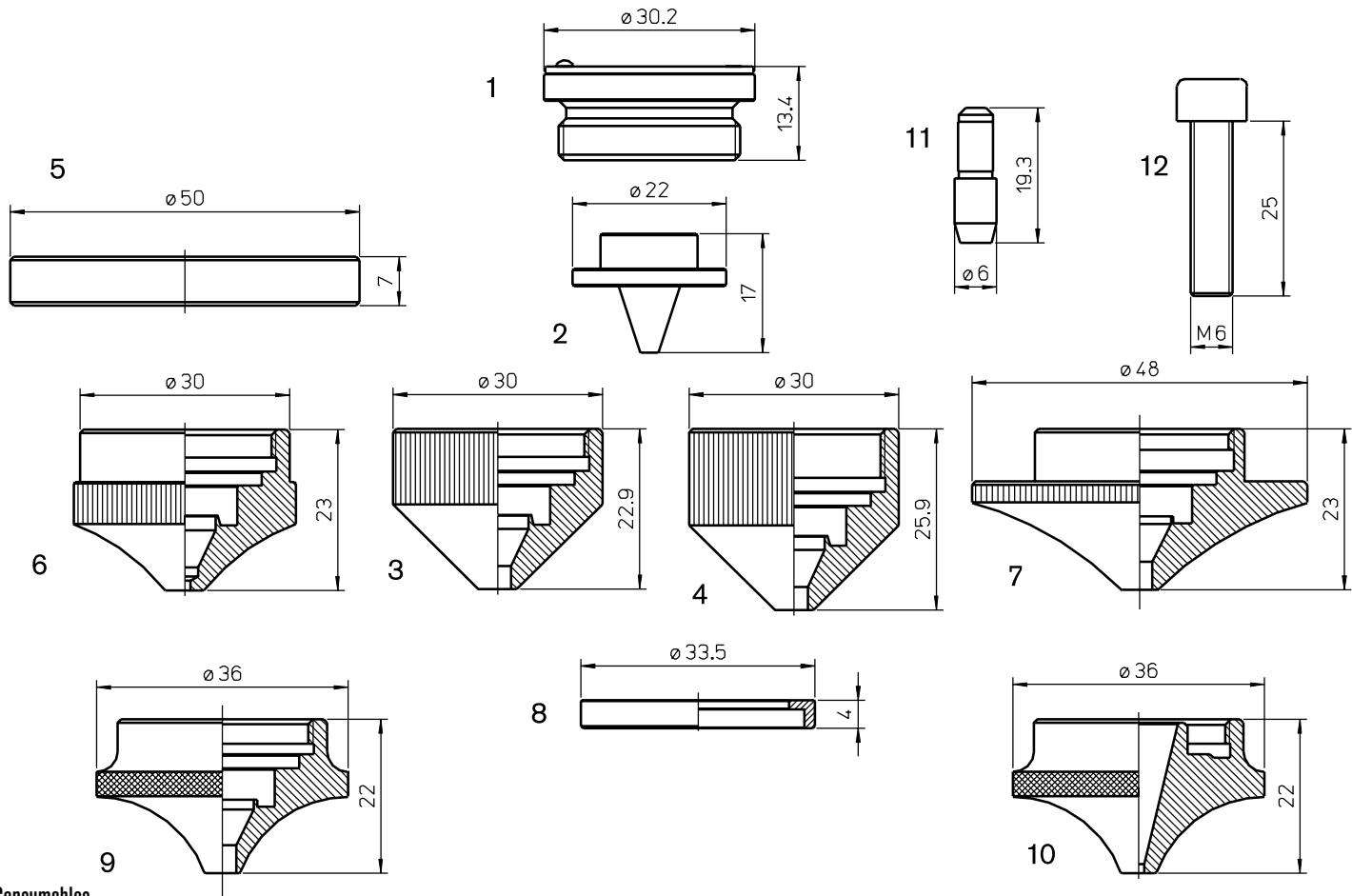
Consumables

	Centricut part number	Reference number	Alternate reference	Description	Pkg qty
1	MB334-0001	P0594-860-00001	AL267	Nozzle Holder – IT HP2 MZP/MEL	1
	MB316-390	W390	L288	Double nozzle insert – 4 holes	1
	MB316-2706	W270-6	L835	Double nozzle insert – 6 holes	1
	MB316-270	W270	L280	Double nozzle insert – 8 holes	1
	MB316-387	W387	L289	Double nozzle insert – 12 holes	1
2	MB316-388	W388	L290	Double nozzle insert – 16 holes	1
	MB316-389	W389	L836	Double nozzle insert – 20 holes	1
	MB316-515	W515	L291	Double nozzle insert – 24 Holes	1
	MB316-269S	71800027, BQ933D221H04, P0593-860-00001	AL238	Shield cap – short	1
3	MB316-269SCP		AL238X	Shield cap – short CP	1
	MB316-269	W269	AL65	Shield cap	1
4	MB316-269CP		AL65X	Shield cap CP	1
	AM416-0001		AL297	Ring (plastic)	1
6	AM416-0002		AL302	Nozzle – 1.7 mm (outer)	1
	AM416-0003		AL303	Nozzle – 2.0 mm (outer)	1
	AM416-0004		AL304	Nozzle – 2.5 mm (outer)	1
	AM416-0005		AL305	Nozzle – 3.0 mm (outer)	1
	AM416-0006		AL306	Nozzle – 4.0 mm (outer)	1
	7	MB316-0440	BQ933D04YH01	AL266	Nozzle, outer – high speed pierce
8	AM416-0155T	71800155TF, BQ023D021H01	AL341-T	Insulation ring – PTFE*	1
	AM416-0155A	71800155AL, BQ023D021H01	AL341-A	Insulation ring – aluminum	1
9	AM416-2197	71802197, BQ933D044H01	AL270	Nozzle, outer	1
10	AM416-5400	7180015400, BQ023D020H01	L1262	Nozzle – 1.7 mm high speed pierce	1
11	AM416-0009	71800009, P921K000P25, JPZA5-6	AL345	Safety pin	1
12	AM416-A005	71800008, L2490A005	AL346	Safety screw	1

*PolyTetraFluoroEthylene is a fluorocarbon-based polymer and is commonly abbreviated PTFE. The Teflon® brand of PTFE is manufactured only by DuPont and is not sold by Hypertherm. Hypertherm purchases other brands of PTFE from various high quality manufacturers.

Centricut is a registered trademark of Hypertherm Inc. and may be registered in the United States and/or other countries. All other trademarks are the properties of their respective owners. Centricut is in no way affiliated with Mitsubishi.

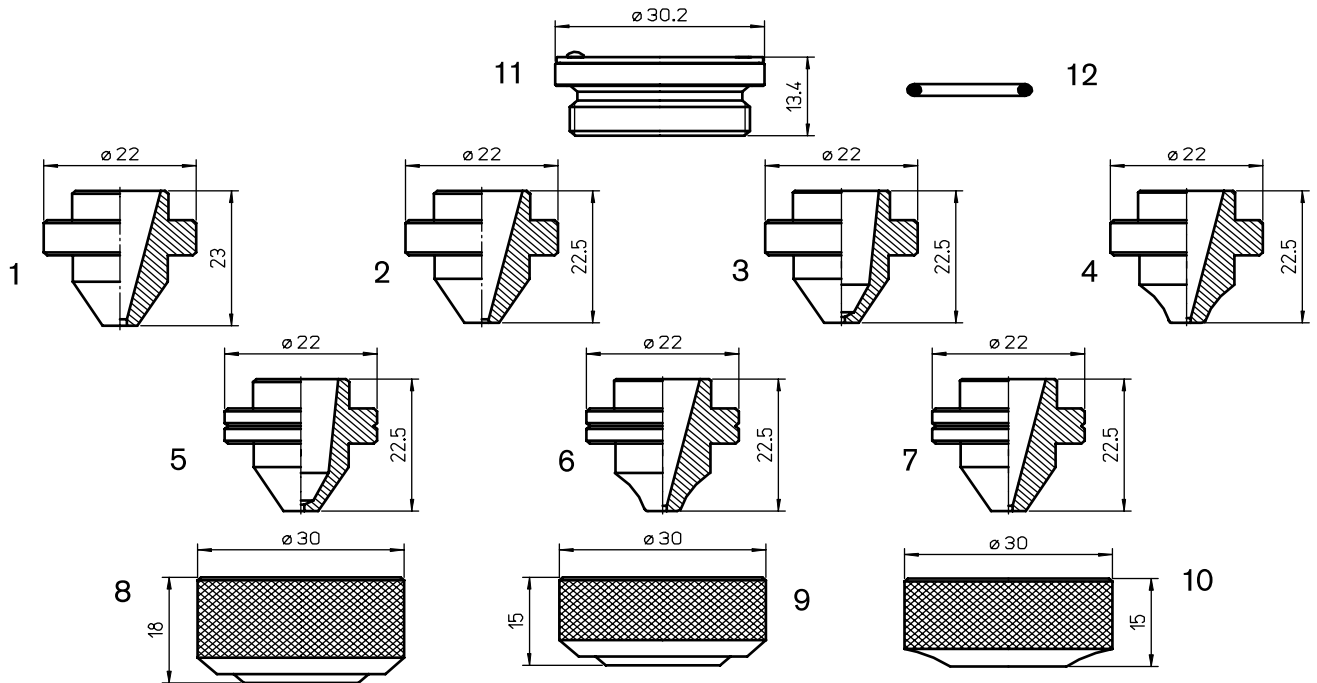

Consumables

	Centricut part number	Reference number	Alternate reference	Description	Pkg qty
1	MB327-327-1		L354	Nozzle - 1.0 mm	1
	MB327-777	W777	L363	Nozzle - 1.2 mm	1
	MB327-266	W266	L355	Nozzle - 1.5 mm	1
	MB327-267	W267	L356	Nozzle - 2.0 mm	1
	MB327-776	W776	L357	Nozzle - 2.5 mm	1
	MB327-268	W268	L358	Nozzle - 3.0 mm	1
	MB327-268-3.5	W268-3.5	L359	Nozzle - 3.5 mm	1
2	AM326-0018	71800018, BQ943D157H01	L1134	Nozzle - 1.5 mm	1
	AM326-0019	71800019, BQ943D157H02	L1135	Nozzle - 2.0 mm	1
	AM326-0020	71800020, BQ943D157H03	L1136	Nozzle - 2.5 mm	1
	AM326-0021	71800021, BQ943D157H04	L1137	Nozzle - 3.0 mm	1
	AM326-0022	71800022, BQ943D596H01	L1138	Nozzle - 3.5 mm	1
3	AM387-0016	71800016, BQ943D897H01, W18Q94389701	L1125	Nozzle - 1.0 mm	1
	AM387-1901	W18Q93309101	L1128	Nozzle - 2.5 mm	1
	AM387-1902	W18Q93309102	L1129	Nozzle - 3.0 mm	1
4	AM387-0001	71800016A0, BQ933D283H01	L1126	Nozzle - 1.0 mm w/radius no grooves	1
5	MB327-0010		L965	Nozzle - 1.0 mm	1
	MB327-0012		L966	Nozzle - 1.2 mm	1
	MB327-0015		L967	Nozzle - 1.5 mm	1
	MB327-0017		L964	Nozzle - 1.7 mm	1
	MB327-0020		L968	Nozzle - 2.0 mm	1
	MB327-0025		L969	Nozzle - 2.5 mm	1
6	AM387-0017	71800017, BQ943D269H01, W18Q93326901	L1130	Nozzle - 1.2 mm w/radius	1
7	AM387-2701	W18Q93302701	L1132	Nozzle - 1.7 mm	1
8	MB327-263	W263	AL116	Nozzle nut	1
9	MB327-263S		AL240	Nozzle nut short	1
10	AM367-0269	71800026, BQ933D94H01	AL269	Nozzle nut short	1
11	MB334-0001	P0594-860-00001	AL267	Nozzle holder - IT HP2 MZP/MEL	1
12	MB334-W290	W290	AL388	O-ring	1

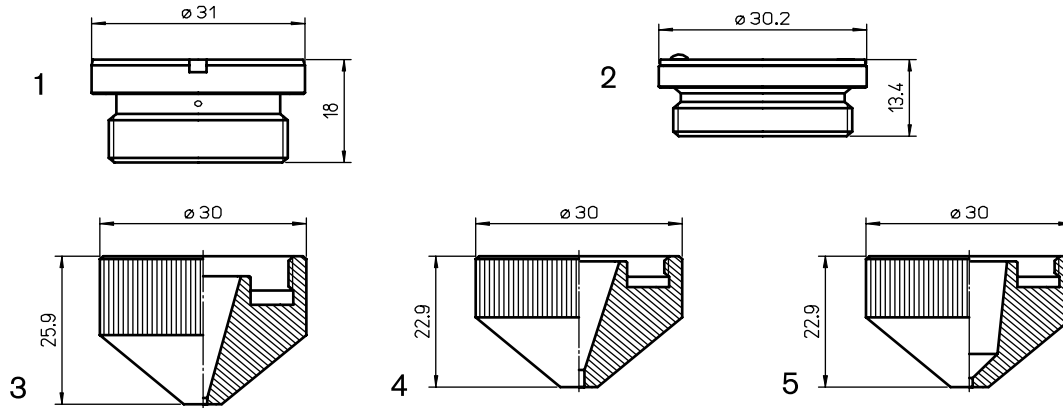

Consumables

	Centricut part number	Reference number	Alternate reference	Description	Pkg qty
1	MB334-0830	P0461-230-00001, W830	AL373	Nozzle Holder - IT461	1
2	MB334-0001	P0594-860-00001	AL267	Nozzle holder - IT HP2 MZP/MEL	1
3	MB334-1249	W1249	L398	Nozzle - 1.0 mm	1
	MB334-1256	W1256	L397	Nozzle - 1.2 mm	1
	MB334-1250	W1250	L399	Nozzle - 1.5 mm	1
	MB334-1251	W1251	L702	Nozzle - 2.0 mm	1
	MB334-1252	W1252	L703	Nozzle - 2.5 mm	1
	MB334-1253	W1253	L704	Nozzle - 3.0 mm	1
	MB334-1254	W1254	L705	Nozzle - 3.5 mm	1
	MB334-1255	W1255	L706	Nozzle - 4.0 mm	1
4	MB334-1626	W1626	L910	Nozzle - 1.0 mm	1
	MB334-1627	W1627	L911	Nozzle - 1.2 mm	1
	MB334-1628	W1628	L912	Nozzle - 1.5 mm	1
	MB334-1661	W1661	L918	Nozzle - 1.7 mm	1
	MB334-1629	W1629	L913	Nozzle - 2.0 mm	1
	MB334-1630	W1630	L914	Nozzle - 2.5 mm	1
	MB334-1664CP	W1664	L915	Nozzle - 3.0 mm	1
	MB334-1665	W1665	L916	Nozzle - 3.5 mm	1
	MB334-1666	W1666	L917	Nozzle - 4.0 mm	1
	MB334-1663	W1663	L919	Nozzle - 5.0 mm	1
	MB334-1626CP	W1626	L910X	Nozzle - 1.0 mm CP	1
	MB334-1627CP	W1627	L911X	Nozzle - 1.2 mm CP	1
	MB334-1628CP	W1628	L912X	Nozzle - 1.5 mm CP	1
	MB334-1661CP	W1661	L918X	Nozzle - 1.7 mm CP	1
	MB334-1629CP	W1629	L913X	Nozzle - 2.0 mm CP	1
	MB334-1630CP	W1630	L914X	Nozzle - 2.5 mm CP	1
	MB334-1664CP	W1664	L915X	Nozzle - 3.0 mm CP	1
	MB334-1665CP	W1665	L916X	Nozzle - 3.5 mm CP	1
MB334-1666CP	W1666	L917X	Nozzle - 4.0 mm CP	1	
5	MB334-1626B	W1626B	L1078	Nozzle - 1.0 mm low pressure	1
	MB334-1627B	W1627B	L1079	Nozzle - 1.2 mm low pressure	1
	MB334-1628B	W1628B	L1080	Nozzle - 1.5 mm low pressure	1
	MB334-1629B	W1629B	L1081	Nozzle - 2.0 mm low pressure	1
	MB334-1630B	W1630B	L1082	Nozzle - 2.5 mm low pressure	1
	MB334-1664B	W1664B	L1083	Nozzle - 3.0 mm low pressure	1
	MB334-1665B	W1665B	L1084	Nozzle - 3.5 mm low pressure	1
	MB334-1666B	W1666B	L1085	Nozzle - 4.0 mm low pressure	1

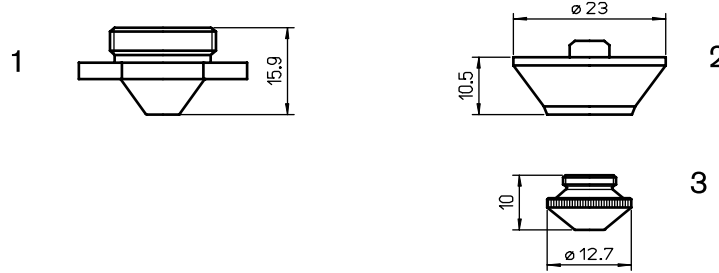

Consumables

	Centricut part number	Reference number	Alternate reference	Description	Pkg qty
1	MB330-000		L548	Nozzle - 1.0 mm	1
	MB330-001	W001	L549	Nozzle - 1.5 mm	1
	MB330-002	W002	L550	Nozzle - 2.0 mm	1
	MB330-004	W004	L551	Nozzle - 2.5 mm	1
	MB330-003	W003	L552	Nozzle - 3.0 mm	1
2	PT344-1079	281079, P0492-430-00003, W149	AL138	OEM nozzle holder - KTM1.5" S F2.5"	1
3	PT344-0013	280013, P0492-441-00008	L400	Nozzle - 0.8 mm	1
	PT344-0013X	280013, P0492-441-00008	L30400	Nozzle - 0.8 mm (10 pack)	10
	MB336-223	NEW W223	L401	Nozzle - 1.0 mm	1
	MB336-223X	280014, P0492-442-00010, W223	L30401	Nozzle - 1.0 mm (10 pack)	10
	PT344-0015	280015, P0492-443-00012	L402	Nozzle - 1.2 mm	1
	PT344-0015X	280015, P0492-443-00012	L30402	Nozzle - 1.2 mm (10 pack)	10
	MB336-224	280016, P0492-444-00015, W224	L403	Nozzle - 1.5 mm	1
	MB336-224X	280016, P0492-444-00015, W224	L30403	Nozzle - 1.5 mm (10 pack)	10
	PT344-0018	P0492-447-00018	L543	Nozzle - 1.8 mm	1
	PT344-0018X	P0492-447-00018	L30543	Nozzle - 1.8 mm (10 pack)	10
	PT344-0937	280937, P0492-445-00020, W225	L544	Nozzle - 2.0 mm	1
	MB336-225X	280937, P0492-445-00020, W225	L30544	Nozzle - 2.0 mm (10 pack)	10
	PT344-0023	P0492-448-00023	L546	Nozzle - 2.3 mm	1
	PT344-0023X	P0492-448-00023	L30546	Nozzle - 2.3 mm (10 pack)	10
	MB336-226	281791, P0492-446-00025, W226	L545	Nozzle - 2.5 mm	1
	MB336-226X	281791, P0492-446-00025, W226	L30545	Nozzle - 2.5 mm (10 pack)	10
	MB336-0005		L547	Nozzle - 3.0 mm	1
	MB336-0005X		L30547	Nozzle - 3.0 mm (10 pack)	10
	PT344-0008CP	280013, P0492-441-00008	L400X	Nozzle - 0.8 mm CP	1
	PT344-0008CPX	280013, P0492-441-00008	L30400X	Nozzle - 0.8 mm CP (10 pack)	10
	PT344-0010CP	280014, P0492-442-00010, W223	L401X	Nozzle - 1.0 mm CP	1
	PT344-0010CPX	280014, P0492-442-00010, W223	L30401X	Nozzle - 1.0 mm CP (10 pack)	10
	PT344-0012CP		L402X	Nozzle - 1.2 mm CP	1
	PT344-0012CPX		L30402X	Nozzle - 1.2 mm CP (10 pack)	10
	PT344-0015CP	280016, P0492-444-00015, W224	L403X	Nozzle - 1.5 mm CP	1
	PT344-0015CPX	280016, P0492-444-00015, W224	L30403X	Nozzle - 1.5 mm CP (10 pack)	10
	PT344-0018CP	P0492-447-00018	L543X	Nozzle - 1.8 mm CP	1
	PT344-0018CPX	P0492-447-00018	L30543X	Nozzle - 1.8 mm CP (10 pack)	10
	PT344-0022CP	280937, P0492-445-00020, W225	L544X	Nozzle - 2.0 mm CP	1
	PT344-0022CPX	280937, P0492-445-00020, W225	L30544X	Nozzle - 2.0 mm CP (10 pack)	10
	PT344-0023CP	P0492-448-00023	L546X	Nozzle - 2.3 mm CP	1
	PT344-0023CPX	P0492-448-00023	L30546X	Nozzle - 2.3 mm CP (10 pack)	10
	PT344-0025CP	281791, P0492-446-00025, W226	L545X	Nozzle - 2.5 mm CP	1
PT344-0025CPX	281791, P0492-446-00025, W226	L30545X	Nozzle - 2.5 mm CP (10 pack)	10	
PT344-0027CP		L547X	Nozzle - 3.0 mm CP	1	
PT344-0027CPX		L30547X	Nozzle - 3.0 mm CP (10 pack)	10	

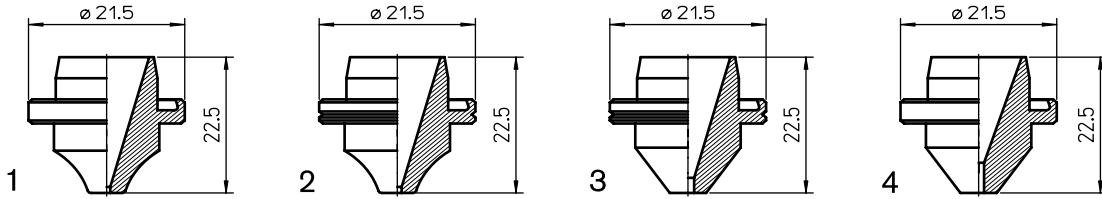

Consumables

	Centricut part number	Reference number	Alternate reference	Description	Pkg qty
1	MB327-1620 NEW	BQ983D150-H01	L1620	Nozzle - 1.0 mm	1
	MB327-1633 NEW	BQ983D314-H01	L1633	Nozzle - 1.4 mm	1
2	MB327-1621 NEW	BQ983D151-H01	L1621	Nozzle - 1.2 mm	1
3	MB327-1622 NEW	BQ983D152-H01	L1622	Nozzle - 1.7 mm	1
4	MB327-1623 NEW	BQ983D153-H01	L1623	Nozzle - 1.5 mm	1
	MB327-1624 NEW	BQ963D153-H02	L1624	Nozzle - 2.0 mm	1
	MB327-1625 NEW	BQ983D314-H03	L1625	Nozzle - 2.5 mm	1
	MB327-1626 NEW	BQ983D151-H04	L1626	Nozzle - 3.0 mm	1
	MB327-1627 NEW	BQ983D152-H05	L1627	Nozzle - 3.5 mm	1

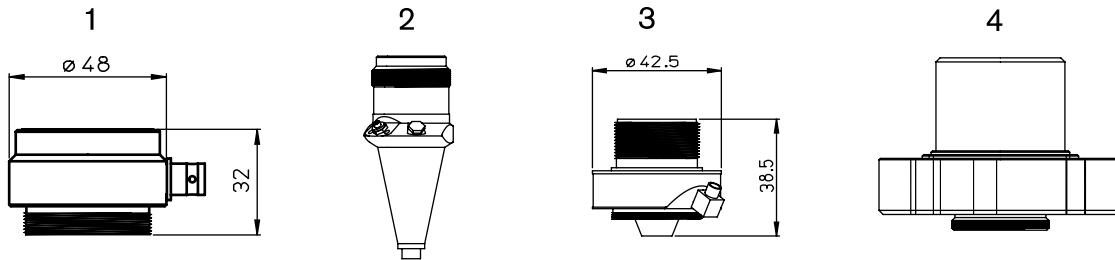

Sensor cones

	Centricut part number	Reference number	Alternate reference	Description	Pkg qty
Sensor cone repair					
1	MB999-429A	W429A	461	Sensor repair W429A	1
2	PT999-HNZ	56743300500		Sensor repair HNZ	1
3	PT999-25ZJ	P0361-203-00001		Sensor repair 25ZJ	1
	MB999-239	W239		Sensor repair W239	1
4	MB999-SE	P0594-820-00001		Sensor repair SE	1
New sensor cones					
2	PT347-0011 NEW	P0354-110-00002		Sensor cone HNZ	1

Sensor repairs available in select regions only.

Optics

Centricut part number	Reference number	Type	Diameter	Focal length	Edge thickness
Lenses					
MB312-018	W018	PLX	1.5"	7.5"	.310"
MB312-500	W500	PLX	1.5"	5.0"	.310"
MB312-505	W505	PLX	2.0"	5.0"	.310"
MB312-510	W510	PLX	2.0"	7.5"	.310"
Ultra low absorption lenses					
MB312-018MP5	W018	PLX	1.5"	7.5"	.300"
MB312-505MP5	W505	PLX	2.0"	5.0"	.310"
MB312-510MP5	W510	PLX	2.0"	7.5"	.310"

Centricut part number	Reference number	Material	Diameter	Edge thickness	S1
Phase shift mirrors					
MB316-004	R004	SI	2.0"	.200"	

Centricut part number	Reference number	Type	Material	Diameter	Edge thickness	S1
Collimating optics						
MB312-250	R250		ZNSE	1.5"	.1575"	11M
MB312-8200	NEW 408200		CU	1.5"	.160"	8M PO/CX
MB312-298	R298	MMR	CU	2.36"	.118"	
MB312-1529	W1529	MMR	CU	2.36"	.236"	15MCC
MB312-1528	W1528	MMR	CU	2.36"	.236"	22MCC
Zero phase shift mirrors and total reflectors						
MB312-106	R106	TRZ	CU	1.1"	.236"	
MB312-107	R107	TRZ	CU	2.0"	.354"	
MB312-102	W102	ZPS	CU	2.0"	.200"	
MB312-051	R051	ZPS	CU	2.36"	.236"	
MB312-160	R160 & R160A	ZPS	CU	3.0"	.236"	
MB312-644	W644	TRZ	CU	2.36"	.591"	
MB312-643	W643	TRZ	CU	3.0"	.591"	
MB312-9719	219719	TRZ	SI	1.1"	.236"	
MB312-571	R571	TRZ	SI	1.41"	.236"	
MB312-321	R321	TRZ	SI	1.96"	.354"	

Centricut part number	Reference number	Type	Diameter	Focal length	Edge thickness
Absorbing thin film reflectors (ATFR)					
MB312-8695	Q919D006H01A	ATFR	CU	2.36"	.590"

Centricut part number	Reference number	Material	Diameter	Edge thickness	S1/Reflectivity	S2
Output couplers						
MB312-9832	NEW 969832	ZNSE	1.1"	.220"	10MCC-60%	5MCX
MB312-259	R259	ZNSE	1.5"	.236"	10MCC-17%	15MCX
MB312-519	R519	ZNSE	1.5"	.236"	10MCC-17%	10MC
MB312-508	R508	ZNSE	1.5"	.236"	10MCC-30%	10MCX
MB312-7233	NEW 247233	ZNSE	1.5"	.236"	10MC-30%	20MX
MB312-500R	R500	ZNSE	1.5"	.236"	20MCC-30%	
MB312-500-50	NEW 763638	ZNSE	1.5"	.236"	20MCC 50%	
MB312-570	R570	ZNSE	2.0"	0.236	14MCC-17%	20MCX

Optics

Centricut part number	Reference number	Material	Diameter	Edge thickness	S1/Reflectivity	S2
Rear mirrors						
MB312-003	R003	ZNSE	1.5"	.236"	20MCC-99%	
MB312-572	R572	ZNSE	1.5"	.354"	25MCC-99%	

Optics care

Centricut part number	Reference number	Description	Pkg qty
TR300-6452	N/A	Lens cleaning paper, Tiffen – 50 piece	1
AM313-SC50 NEW	SC50	Lens cleaning paper, Tresor – 50 piece	1
TR300-1115		Lens cleaning pre-cut cotton – 80 piece	1
TR300-SC20		Cotton swab – 20 piece	1
TR300-1010	AL1010	Dropper, lens cleaning fluid	1
TR300-255	AL255	Loupe, magnifying	1
TR300-271	AL271	Base, lens maintenance	1
TR300-7388	787388	Mirror polish (250 ml)	1
AM313-1260 NEW	351260-009	Lens Polarizing Filter – 1.5"	1
AM313-1280 NEW	351280-009	Lens Polarizing Filter – 2.0"	1

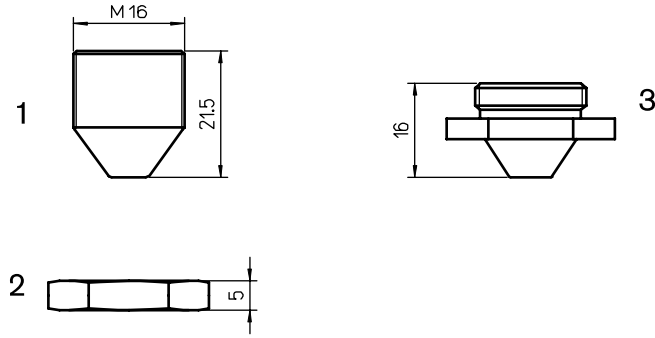
Consumables

	Centricut part number	Reference number	Alternate reference	Description	Pkg qty
1	WI338-1210	P26-71270-60-1.0	L66	Nozzle - 1.0 mm	1
	WI338-1214	P26-71270-60-1.4	L125	Nozzle - 1.4 mm	1
	WI338-1215	P26-71270-60-1.5	L279	Nozzle - 1.5 mm	1
2	WI338-0001		AL46	Retainer nut	1
3	WI338-1110	P37-71110-039-1.0	L309	Nozzle - 1.0 mm	1
	WI338-1112	P37-71110-039-1.2	L460	Nozzle - 1.2 mm	1
	WI338-1115	P37-71110-039-1.5	L310	Nozzle - 1.5 mm	1
	WI338-1120	P37-71110-039-2.0	L311	Nozzle - 2.0 mm	1
	WI338-1125	P37-71110-039-2.5	L314	Nozzle - 2.5 mm	1

Optics care

Centricut part number	Reference number	Description	Pkg qty
TR300-6452	N/A	Lens cleaning paper, Tiffen - 50 piece	1
AM313-SC50 NEW	SC50	Lens cleaning paper, Tresor - 50 piece	1
TR300-1115		Lens cleaning pre-cut cotton - 80 piece	1
TR300-SC20		Cotton swab - 20 piece	1
TR300-1010	AL1010	Dropper, lens cleaning fluid	1
TR300-255	AL255	Loupe, magnifying	1
TR300-271	AL271	Base, lens maintenance	1
TR300-7388	787388	Mirror polish (250 ml)	1
AM313-1260 NEW	351260-009	Lens Polarizing Filter - 1.5"	1
AM313-1280 NEW	351280-009	Lens Polarizing Filter - 2.0"	1

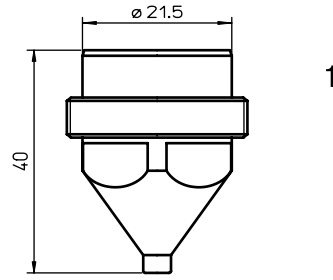
Consumables

	Centricut part number	Reference number	Alternate reference	Description	Pkg qty
1	NI400-0001		L1007	Nozzle - 2.0 mm	1

Optics care

Centricut part number	Reference number	Description	Pkg qty
TR300-6452	N/A	Lens cleaning paper, Tiffen - 50 piece	1
AM313-SC50 NEW	SC50	Lens cleaning paper, Tresor - 50 piece	1
TR300-1115		Lens cleaning pre-cut cotton - 80 piece	1
TR300-SC20		Cotton swab - 20 piece	1
TR300-1010	AL1010	Dropper, lens cleaning fluid	1
TR300-255	AL255	Loupe, magnifying	1
TR300-271	AL271	Base, lens maintenance	1
TR300-7388	787388	Mirror polish (250 ml)	1
AM313-1260 NEW	351260-009	Lens Polarizing Filter - 1.5"	1
AM313-1280 NEW	351280-009	Lens Polarizing Filter - 2.0"	1

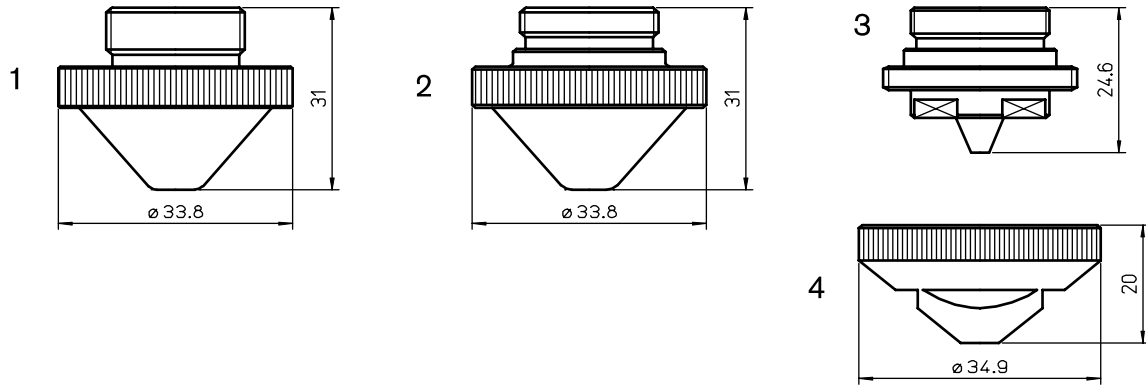
Consumables

	Centricut part number	Reference number	Alternate reference	Description	Pkg qty
1	NT401-0001		L454	Nozzle - 1.0 mm	1
	NT401-0002		L455	Nozzle - 1.2 mm	1
	NT401-0003		L456	Nozzle - 1.5 mm	1
	NT401-0004		L457	Nozzle - 2.0 mm	1
	NT401-0005		L458	Nozzle - 2.5 mm	1
	NT401-0006		L459	Nozzle - 3.0 mm	1
2	NT382-3738	4R019681	L1090	Nozzle - 1.0 mm	1
	NT382-3737	4R023668	L1091	Nozzle - 1.2 mm	1
	NT382-3904	4R020576	L1092	Nozzle - 1.5 mm	1
	NT382-3739	4R019680	L1093	Nozzle - 2.0 mm	1
	NT382-0025		L1096	Nozzle - 2.5 mm	1
	NT382-3905	4R019770	L1094	Nozzle - 3.0 mm	1
	NT382-0040		L1095	Nozzle - 4.0 mm	1
3	NT382-0001		L1100	Nozzle - 1.7 mm w/holes	1
4	NT382-0002		AL262	Retainer nut	1

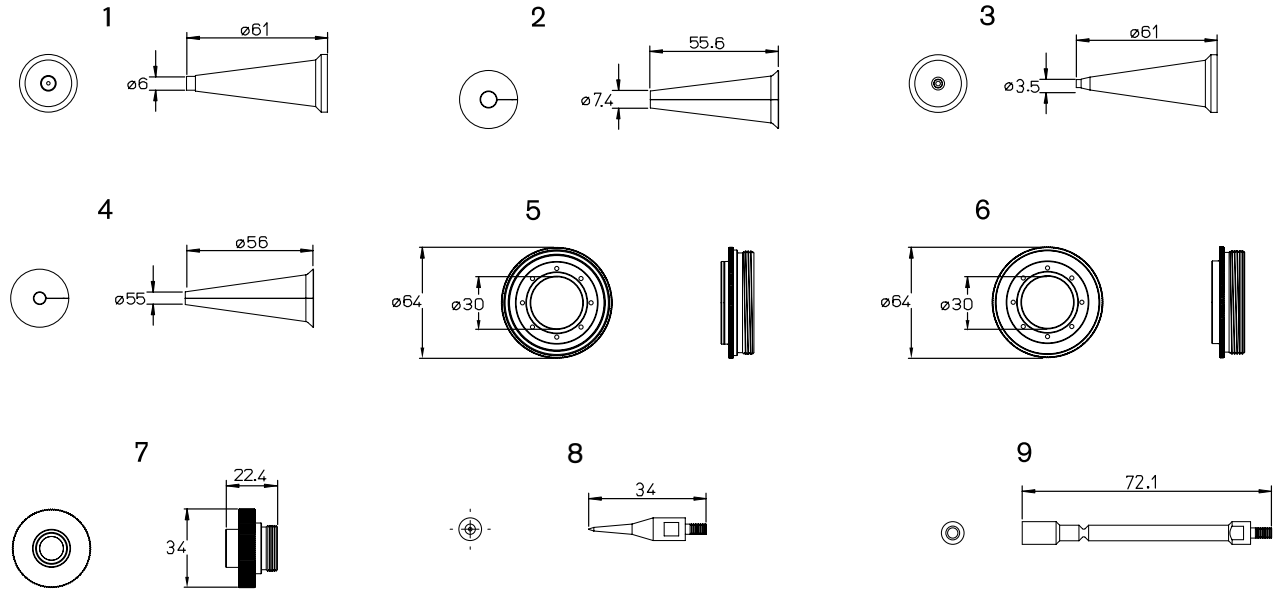
Consumables

	Centricut part number	Reference number	Alternate reference	Description	Pkg qty
1	NT426-0515	4R018705-001		Nozzle - 1.5 mm ceramic standard	1
	NT426-0520	4R018705-002		Nozzle - 2.0 mm ceramic standard	1
2	NT426-3962	4R003962-001		Cap - nozzle (standard)	1
3	NT426-6515	4R008865-002		Nozzle - 1.5 mm ceramic (small)	1
	NT426-6520	4R008865-001		Nozzle - 2.0 mm ceramic (small)	1
4	NT426-8866	4R008866-001		Cap - nozzle (small)	1
5	NT426-8415	4R018452-001		Flange - 0.15" (new style)	1
	NT426-8430	4R18452-002		Flange - 0.30" (new style)	1
	NT426-8450	4R032035-001		Flange - 0.50" (new style)	1
6	NT426-4446	4R004446-001		Flange - 0.15" (old style)	1
	NT426-6511	4R006511-001		Flange - 0.30" (old style)	1
	NT426-2632 (not shown)	3R002632-G03		Nozzle holder - ceramic (old style)	1
	NT426-6928 (not shown)	3R016928-G01		Nozzle holder - ceramic (new style)	1
7	NT426-7758	NEW 4R037758-001		Nozzle base	1
	NT426-0001 (not shown)	NEW N-G O-RINGS		O-rings for nozzle holders	1
	NT426-3765 (not shown)	4R003765-001		Nozzle nut	1
8	NT426-3540	4R003540-001		Stylus	1
9	NT426-2720	4R012720-001		Stylus adaptor	1
	NT426-1682 (not shown)	4R029911-001		Sensor cable - 216 mm (8.5")	1
	NT426-8677 (not shown)	4R028677-001		Sensor cable - armored 508 mm (20")	1
	NT426-4991 (not shown)	3-0104991		Sensor cable - 482 mm (19")	1
	NT426-7492 (not shown)	3-0117492		Sensor cable - 482 mm (19")	1

Optics

Centricut part number	Reference number	Type	Diameter	Focal length	Edge thickness
Lenses					
NT375-6491	706491	PLX	1.5"	5.0"	.160"
NT375-8662	578662	PLX	1.5"	5.0"	.300"
NT375-4494	634494	PLX	2.0"	7.5"	.300"
Phase shift mirrors					
NT375-8091	61785	PS	SI	3.0"	.250"

Centricut part number	Reference number	Type	Material	Diameter	Edge thickness	S1
Zero phase shift mirrors and total reflectors						
NT375-8321	478321	TRZ	SI	1.75"	.160"	22.5
NT375-4442	304442	TRZ	SI	1.75"	.160"	45
NT375-1165		TRZ	CU	1.96"	0.59"	3.8CX-EG
NT375-9070		TRZ	CU	1.96"	0.59"	3.7CC-EG
NT375-7753	957753	TRZ	CU	1.96"	.984"	EG WC

Centricut part number	Reference number	Material	Diameter	Edge thickness	S1/Reflectivity	S2
Output couplers						
NT375-3547	793547	ZNSE	1.0"	.236"	20MCC-65%	12MCX
Rear mirrors						
NT375-0566	160566	GA	1.1"	.120"	20MCC-99.5%	PO/AR

Optics care

Centricut part number	Reference number	Description	Pkg qty
TR300-6452	N/A	Lens cleaning paper, Tiffen - 50 piece	1
AM313-SC50 NEW	SC50	Lens cleaning paper, Tresor - 50 piece	1
TR300-1115		Lens cleaning pre-cut cotton - 80 piece	1
TR300-SC20		Cotton swab - 20 piece	1
TR300-1010	AL1010	Dropper, lens cleaning fluid	1
TR300-255	AL255	Loupe, magnifying	1
TR300-271	AL271	Base, lens maintenance	1
TR300-7388	787388	Mirror polish (250 ml)	1
AM313-1260 NEW	351260-009	Lens Polarizing Filter - 1.5"	1
AM313-1280 NEW	351280-009	Lens Polarizing Filter - 2.0"	1

For Adige, Durma, Ermaksan, Finn Power, GHT, Hans, Mazak, SHT and Salvagnini systems

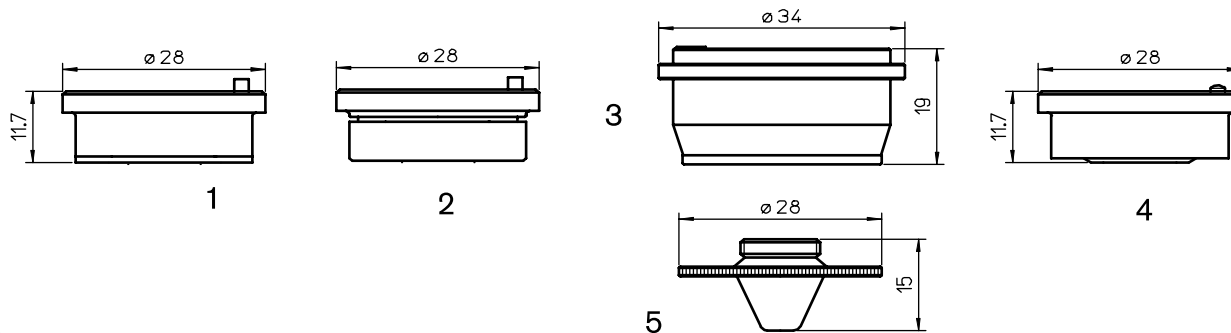

Consumables

	Centricut part number	Reference number	Alternate reference	Description	Pkg qty
1	PT348-1330	281330, P0571-260-00001	AL131	Nozzle holder - ceramic	1
	PT348-1330OEM	281330, P0571-260-00001	AL23	Nozzle holder - ceramic (OEM)	1
	PT348-1051	P0571-1051-00001	AL355	Nozzle holder - OEM KT B2"	1
2	PT348-1330C NEW	P0571-260-00001	AL131, AL331	Nozzle holder - ceramic	1
3	PT348-1001		AL228	Nozzle holder	1
4	PT348-1518	281518, P0571-265-00001	AL141	Nozzle holder - IT B2" Z - aluminum	1
5	PT350-1590	281590, P0591-569-00008	L247	Nozzle - 0.8 mm	1
	PT350-1590X NEW	281590, P0591-569-00008	L30247	Nozzle - 0.8 mm (10 pack)	10
	PT350-1331	281331, P0591-561-00010	L162	Nozzle - 1.0 mm	1
	PT350-1331X NEW	281331, P0591-561-00010	L30162	Nozzle - 1.0 mm (10 pack)	10
	PT350-1351	281351, P0591-562-00012	L130	Nozzle - 1.2 mm	1
	PT350-1351X NEW	281351, P0591-562-00012	L30130	Nozzle - 1.2 mm (10 pack)	10
	PT350-1352	281352, P0591-563-00015	L131	Nozzle - 1.5 mm	1
	PT350-1352X NEW	281352, P0591-563-00015	L30131	Nozzle - 1.5 mm (10 pack)	10
	PT350-0017		L248	Nozzle - 1.7 mm	1
	PT350-0017X NEW		L30248	Nozzle - 1.7 mm (10 pack)	10
	PT350-1353	281353, P0591-564-00018	L153	Nozzle - 1.8 mm	1
	PT350-1353X NEW	281353, P0591-564-00018	L30153	Nozzle - 1.8 mm (10 pack)	10
	PT350-1354	281354, P0591-565-00020	L132	Nozzle - 2.0 mm	1
	PT350-1354X NEW	281354, P0591-565-00020	L30132	Nozzle - 2.0 mm (10 pack)	10
	PT350-0023		L154	Nozzle - 2.3 mm	1
	PT350-0023X NEW		L30154	Nozzle - 2.3 mm (10 pack)	10
	PT350-1591	281591, P0591-566-00025	L155	Nozzle - 2.5 mm	1
	PT350-1591X NEW	281591, P0591-566-00025	L30155	Nozzle - 2.5 mm (10 pack)	10
	PT350-0030		L156	Nozzle - 3.0 mm	1
	PT350-0030X NEW		L30156	Nozzle - 3.0 mm (10 pack)	10
	PT350-1590CP	281590, P0591-569-00008	L247X	Nozzle - 0.8 mm CP	1
	PT350-1590CPX NEW	281590, P0591-569-00008	L30247X	Nozzle - 0.8 mm CP (10 pack)	10
	PT350-1331CP	281331, P0591-561-00010	L162X	Nozzle - 1.0 mm CP	1
	PT350-1331CPX NEW	281331, P0591-561-00010	L30162X	Nozzle - 1.0 mm CP (10 pack)	10
	PT350-1351CP	281351, P0591-562-00012	L130X	Nozzle - 1.2 mm CP	1
	PT350-1351CPX NEW	281351, P0591-562-00012	L30130X	Nozzle - 1.2 mm CP (10 pack)	10
	PT350-1352CP	281352, P0591-563-00015	L131X	Nozzle - 1.5 mm CP	1
	PT350-1352CPX NEW	281352, P0591-563-00015	L30131X	Nozzle - 1.5 mm CP (10 pack)	10
	PT350-0001CP		L248X	Nozzle - 1.7 mm CP	1
	PT350-0001CPX NEW		L30248X	Nozzle - 1.7 mm CP (10 pack)	10
	PT350-1353CP	281353, P0591-564-00018	L153X	Nozzle - 1.8 mm CP	1
	PT350-1353CPX NEW	281353, P0591-564-00018	L30153X	Nozzle - 1.8 mm CP (10 pack)	10
	PT350-1354CP	281354, P0591-565-00020	L132X	Nozzle - 2.0 mm CP	1
	PT350-1354CPX NEW	281354, P0591-565-00020	L30132X	Nozzle - 2.0 mm CP (10 pack)	10
	PT350-0002CP		L154X	Nozzle - 2.3 mm CP	1
	PT350-0002CPX NEW		L30154X	Nozzle - 2.3 mm CP (10 pack)	10
	PT350-1591CP	281591, P0591-566-00025	L155X	Nozzle - 2.5 mm CP	1
	PT350-1591CPX NEW	281591, P0591-566-00025	L30155X	Nozzle - 2.5 mm CP (10pack)	10
	PT350-0003CP		L156X	Nozzle - 3.0 mm CP	1
	PT350-0003CPX NEW		L30156X	Nozzle - 3.0 mm CP (10 pack)	10

Centricut is a registered trademark of Hypertherm Inc. and may be registered in the United States and/or other countries. All other trademarks are the properties of their respective owners. Centricut is in no way affiliated with Precitec.

For Adige, Durma, Ermaksan, Finn Power, GHT and Salvagnini systems

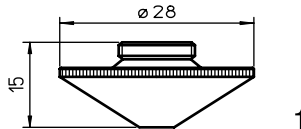

Consumables

Centricut part number	Reference number	Alternate reference	Description	Pkg qty
PT345-0008		L935	Nozzle - 0.8 mm HD	1
PT345-0008X NEW		L30935	Nozzle - 0.8 mm HD (10 pack)	10
PT345-1548	281548, P0591-571-00010	L234	Nozzle - 1.0 mm HD	1
PT345-1548X NEW		L30234	Nozzle - 1.0 mm HD (10 pack)	10
PT345-1549	281549, P0591-572-00012	L235	Nozzle - 1.2 mm HD	1
PT345-1549X NEW		L30235	Nozzle - 1.2 mm HD (10 pack)	10
PT345-1463	281463, P0591-573-00015	L236	Nozzle - 1.5 mm HD	1
PT345-1463X NEW		L30236	Nozzle - 1.5 mm HD (10 pack)	10
PT345-0001	P0591-574-00018	L237	Nozzle - 1.8 mm HD	1
PT345-0001X NEW		L30237	Nozzle - 1.8 mm HD (10 pack)	10
PT345-1550	281550, P0591-575-00020	L238	Nozzle - 2.0 mm HD	1
PT345-1550X NEW		L30238	Nozzle - 2.0 mm HD (10 pack)	10
PT345-0003		L239	Nozzle - 2.3 mm HD	1
PT345-0003X NEW		L30239	Nozzle - 2.3 mm HD (10 pack)	10
PT345-1551	281551, P0591-576-00025	L240	Nozzle - 2.5 mm HD	1
PT345-1551X NEW		L30240	Nozzle - 2.5 mm HD (10 pack)	10
PT345-1552		L936	Nozzle - 2.75 mm HD	1
PT345-1552X NEW		L30936	Nozzle - 2.75 mm HD (10 pack)	10
PT345-0002		L241	Nozzle - 3.0 mm HD	1
PT345-0002X NEW		L30241	Nozzle - 3.0 mm HD (10 pack)	10
PT345-0005		L826	Nozzle - 3.2 mm HD	1
PT345-0005X NEW		L30826	Nozzle - 3.2 mm HD (10 pack)	10
PT345-0006		L827	Nozzle - 3.5 mm HD	1
PT345-0006X NEW		L30827	Nozzle - 3.5 mm HD (10 pack)	10
PT345-0004		L828	Nozzle - 4.0 mm HD	1
PT345-0004X NEW		L30828	Nozzle - 4.0 mm HD (10 pack)	10
PT345-0007		L829	Nozzle - 4.5 mm HD	1
PT345-0007X NEW		L30829	Nozzle - 4.5 mm HD (10 pack)	10
PT345-1547CP		L935X	Nozzle - 0.8 mm HD CP	1
PT345-1547CPX NEW		L30935X	Nozzle - 0.8 mm HD CP (10 pack)	10
PT345-1548CP	281548, P0591-571-00010	L234X	Nozzle - 1.0 mm HD CP	1
PT345-1548CPX NEW	281548, P0591-571-00010	L30234X	Nozzle - 1.0 mm HD CP (10 pack)	10
PT345-1549CP	281549, P0591-572-00012	L235X	Nozzle - 1.2 mm HD CP	1
PT345-1549CPX NEW	281549, P0591-572-00012	L30235X	Nozzle - 1.2 mm HD CP (10 pack)	10
PT345-1463CP	281463, P0591-573-00015	L236X	Nozzle - 1.5 mm HD CP	1
PT345-1463CPX NEW	281463, P0591-573-00015	L30236X	Nozzle - 1.5 mm HD CP (10 pack)	10
PT345-0001CP		L237X	Nozzle - 1.8 mm HD CP	1
PT345-0001CPX NEW		L30237X	Nozzle - 1.8 mm HD CP (10 pack)	10
PT345-1550CP	281550, P0591-575-00020	L238X	Nozzle - 2.0 mm HD CP	1
PT345-1550CPX NEW	281550, P0591-575-00020	L30238X	Nozzle - 2.0 mm HD CP (10 pack)	10
PT345-0003CP		L239X	Nozzle - 2.3 mm HD CP	1
PT345-0003CPX NEW		L30239X	Nozzle - 2.3 mm HD CP (10 pack)	10
PT345-1551CP	281551, P0591-576-00025	L240X	Nozzle - 2.5 mm HD CP	1
PT345-1551CPX NEW	281551, P0591-576-00025	L30240X	Nozzle - 2.5 mm HD CP (10 pack)	10
PT345-1552CP		L936X	Nozzle - 2.75 mm HD CP	1
PT345-1552CPX NEW		L30936X	Nozzle - 2.75 mm HD CP (10 pack)	10
PT345-0002CP		L241X	Nozzle - 3.0 mm HD CP	1
PT345-0002CPX NEW		L30241X	Nozzle - 3.0 mm HD CP (10 pack)	10
PT345-0005CP		L826X	Nozzle - 3.2 mm HD CP	1
PT345-0005CPX NEW		L30826X	Nozzle - 3.2 mm HD CP (10 pack)	10
PT345-0006CP		L827X	Nozzle - 3.5 mm HD CP	1
PT345-0006CPX NEW		L30827X	Nozzle - 3.5 mm HD CP (10 pack)	10
PT345-0004CP		L828X	Nozzle - 4.0 mm HD CP	1
PT345-0004CPX NEW		L30828X	Nozzle - 4.0 mm HD CP (10 pack)	10
PT345-0007CP		L829X	Nozzle - 4.5 mm HD CP	1
PT345-0007CPX NEW		L30829X	Nozzle - 4.5 mm HD CP (10 pack)	10

Centricut is a registered trademark of Hypertherm Inc. and may be registered in the United States and/or other countries. All other trademarks are the properties of their respective owners. Centricut is in no way affiliated with Precitec.

For Adige, Durma, Ermaksan, Finn Power, GHT and Salvagnini systems

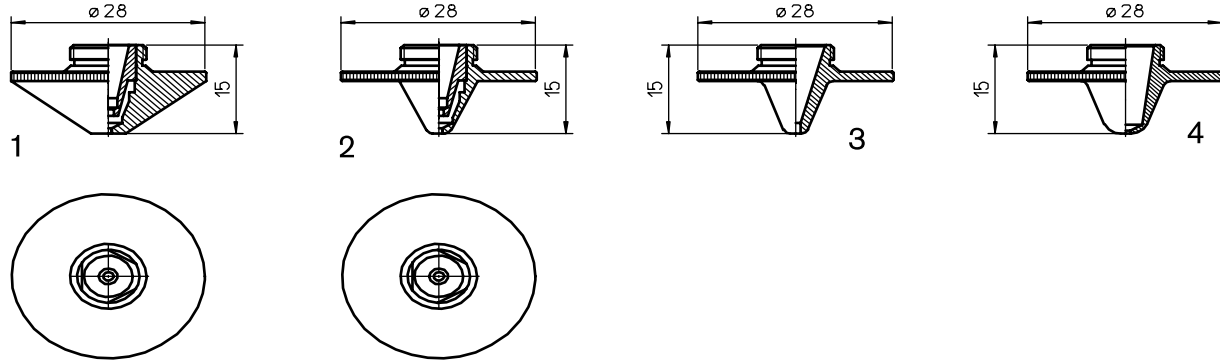

Consumables

	Centricut part number	Reference number	Alternate reference	Description	Pkg qty
	PT358-0669	Centricut design	L669	Nozzle - 0.8 mm double	1
	PT358-0669X NEW	Centricut design	L30669	Nozzle - 0.8 mm double (10 pack)	10
	PT358-0691 NEW	Centricut design	L691	Nozzle - 0.9 mm double	1
	PT358-0691X NEW	Centricut design	L30691	Nozzle - 0.9 mm double (10 pack)	10
	PT358-0010	Centricut design	L660	Nozzle - 1.0 mm double	1
	PT358-0010X NEW	Centricut design	L30660	Nozzle - 1.0 mm double (10 pack)	10
	PT358-0112 NEW	Centricut design	L661-12	Nozzle - 1.2 mm double w/1.2 mm inner	1
	PT358-0112X NEW	Centricut design	L30661-12	Nozzle - 1.2 mm double w/1.2 mm inner (10 pack)	10
	PT358-0125	Centricut design	L661	Nozzle - 1.2 mm double	1
	PT358-0125X NEW	Centricut design	L30661	Nozzle - 1.2 mm double (10 pack)	10
	PT358-0015	Centricut design	L662	Nozzle - 1.5 mm double	1
	PT358-0015X NEW	Centricut design	L30662	Nozzle - 1.5 mm double (10 pack)	10
	PT358-0018	Centricut design	L663	Nozzle - 1.8 mm double	1
	PT358-0018X NEW	Centricut design	L30663	Nozzle - 1.8 mm double (10 pack)	10
	PT358-0020	Centricut design	L664	Nozzle - 2.0 mm double	1
	PT358-0020X NEW	Centricut design	L30664	Nozzle - 2.0 mm double (10 pack)	10
	PT358-0418 NEW	Centricut design	L664-18	Nozzle - 2.0 mm double w/1.8 mm inner	1
	PT358-0418X NEW	Centricut design	L30664-18	Nozzle - 2.0 mm double w/1.8 mm inner (10 pack)	10
	PT358-0023	Centricut design	L665	Nozzle - 2.3 mm double	1
1	PT358-0023X NEW	Centricut design	L30665	Nozzle - 2.3 mm double (10 pack)	10
	PT358-0007	Centricut design	L666	Nozzle - 2.5 mm double	1
	PT358-0007X NEW	Centricut design	L30666	Nozzle - 2.5 mm double (10 pack)	10
	PT358-0030	Centricut design	L667	Nozzle - 3.0 mm double	1
	PT358-0030X NEW	Centricut design	L30667	Nozzle - 3.0 mm double (10 pack)	10
	PT358-0035	Centricut design	L668	Nozzle - 3.5 mm double	1
	PT358-0035X NEW	Centricut design	L30668	Nozzle - 3.5 mm double (10 pack)	10
	PT358-0008CP	Centricut design	L669X	Nozzle - 0.8 mm double CP	1
	PT358-0008CPX NEW	Centricut design	L30669X	Nozzle - 0.8 mm double CP (10 pack)	10
	PT358-0691CP NEW	Centricut design	L691X	Nozzle - 0.9 mm double CP	1
	PT358-0691CPX NEW	Centricut design	L30691X	Nozzle - 0.9 mm double CP (10 pack)	10
	PT358-0010CP	Centricut design	L660X	Nozzle - 1.0 mm double CP	1
	PT358-0010CPX NEW	Centricut design	L30660X	Nozzle - 1.0 mm double CP (10 pack)	10
	PT358-0125CP	Centricut design	L661X	Nozzle - 1.2 mm double CP	1
	PT358-0125CPX NEW	Centricut design	L30661X	Nozzle - 1.2 mm double CP (10 pack)	10
	PT358-0692 NEW	Centricut design	L692	Nozzle - 1.1 mm double	1
	PT358-0692X NEW	Centricut design	L30692	Nozzle - 1.1 mm double (10 pack)	10
	PT358-0015CP	Centricut design	L662X	Nozzle - 1.5 mm double CP	1
	PT358-0015CPX NEW	Centricut design	L30662X	Nozzle - 1.5 mm double CP (10 pack)	10
	PT358-0018CP	Centricut design	L663X	Nozzle - 1.8 mm double CP	1

Consumables

	Centricut part number	Reference number	Alternate reference	Description	Pkg qty
1	PT358-0018CPX NEW	Centricut design	L30663X	Nozzle - 1.8 mm double CP (10 pack)	10
	PT358-0020CP	Centricut design	L664X	Nozzle - 2.0 mm double CP	1
	PT358-0020CPX NEW	Centricut design	L30664X	Nozzle - 2.0 mm double CP (10 pack)	10
	PT358-0023CP	Centricut design	L665X	Nozzle - 2.3 mm double CP	1
	PT358-0023CPX NEW	Centricut design	L30665X	Nozzle - 2.3 mm double CP (10 pack)	10
	PT358-0025CP	Centricut design	L666X	Nozzle - 2.5 mm double CP	1
	PT358-0025CPX NEW	Centricut design	L30666X	Nozzle - 2.5 mm double CP (10 pack)	10
	PT358-0030CP	Centricut design	L667X	Nozzle - 3.0 mm double CP	1
	PT358-0030CPX NEW	Centricut design	L30667X	Nozzle - 3.0 mm double CP (10 pack)	10
	PT358-0035CP	Centricut design	L668X	Nozzle - 3.5 mm double CP	1
PT358-0035CPX NEW	Centricut design	L30668X	Nozzle - 3.5 mm double CP (10 pack)	10	
2	PT358-0001	6930250001	L1348	Nozzle - 0.8 mm 3D double	1
	PT358-0002	6930250002	L1349	Nozzle - 1.0 mm 3D double	1
	PT358-0003	6930250003	L1350	Nozzle - 1.2 mm 3D double	1
	PT358-0004	6930250004	L1351	Nozzle - 1.5 mm 3D double	1
	PT358-0001CP		L1348X	Nozzle - 0.8 mm 3D double CP	1
	PT358-0002CP		L1349X	Nozzle - 1.0 mm 3D double CP	1
	PT358-0003CP		L1350X	Nozzle - 1.2 mm 3D double CP	1
	PT358-0004CP		L1351X	Nozzle - 1.5 mm 3D double CP	1
3	PT406-0001	Centricut design	L738	Nozzle - 1.0 mm HD	1
	PT406-0002	Centricut design	L739	Nozzle - 1.25 mm HD	1
	PT406-0003	Centricut design	L740	Nozzle - 1.5 mm HD	1
4	PT406-0008	Centricut design	L792	Nozzle - 0.8 mm	1
	PT406-0010	Centricut design	L793	Nozzle - 1.0 mm	1
	PT406-0125	Centricut design	L794	Nozzle - 1.25 mm	1
	PT406-0015	Centricut design	L742	Nozzle - 1.5 mm	1
	PT406-0018	Centricut design	L743	Nozzle - 1.8 mm	1
	PT406-0020	Centricut design	L744	Nozzle - 2.0 mm	1

For Adige, Finn Power and GHT systems

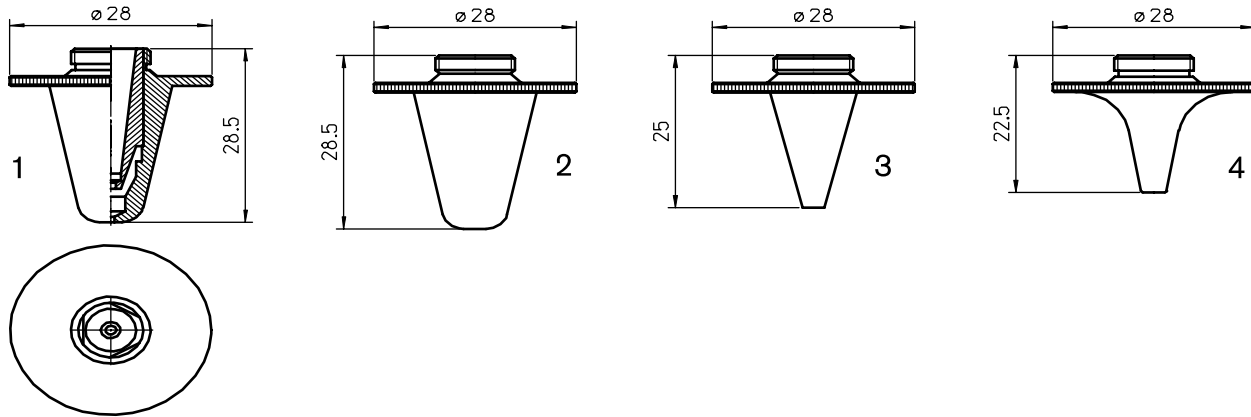

Consumables

	Centricut part number	Reference number	Alternate reference	Description	Pkg qty
1	PT420-0010	Centricut design	L680	Nozzle - 1.0 mm double long	1
	PT420-0125	Centricut design	L681	Nozzle - 1.2 mm double long	1
	PT420-0015	Centricut design	L682	Nozzle - 1.5 mm double long	1
	PT420-0018	Centricut design	L683	Nozzle - 1.8 mm double long	1
	PT420-0020	Centricut design	L684	Nozzle - 2.0 mm double long	1
	PT420-0023	Centricut design	L685	Nozzle - 2.3 mm double long	1
	PT420-0025	Centricut design	L686	Nozzle - 2.5 mm double long	1
	PT420-0030	Centricut design	L687	Nozzle - 3.0 mm double long	1
	PT420-0035	Centricut design	L688	Nozzle - 3.5 mm double long	1
2	PT390-0010	P0573-563-00010	L308	Nozzle - 1.0 mm long	1
	PT390-0012	P0573-563-00012	L307	Nozzle - 1.2 mm long	1
	PT390-0015	P0573-563-00015	L382	Nozzle - 1.5 mm long	1
	PT390-0018		L383	Nozzle - 1.8 mm long	1
	PT390-0020	P0573-564-00020	L437	Nozzle - 2.0 mm long	1
	PT390-0023	P0573-565-00023	L438	Nozzle - 2.3 mm long	1
	PT390-0025	P0573-566-00025	L439	Nozzle - 2.5 mm long	1
	PT390-0030		L440	Nozzle - 3.0 mm long	1
3	PT390-0001		L1341	Nozzle - 1.0 mm long	1
	PT390-0002		L1343	Nozzle - 1.5 mm long	1
	PT390-0003		L1344	Nozzle - 1.8 mm long	1
	PT390-0004		L1345	Nozzle - 2.0 mm long	1
4	PT390-0040	P0578-0411-00010	L1374	Nozzle - 1.0 mm long w/radius	1
	PT390-0005	P0578-0412-00012	L1375	Nozzle - 1.2 mm long w/radius	1
	PT390-0006	P0578-0413-00015	L1376	Nozzle - 1.5 mm long w/radius	1
	PT390-0009	P0578-0414-00018	L1373	Nozzle - 1.8 mm long w/radius	1
	PT390-0007	P0415-0411-00020	L1377	Nozzle - 2.0 mm long w/radius	1
	PT390-0008	P0578-0415-00020	L1378	Nozzle - 2.5 mm long w/radius	1
	PT390-0040CP		L1374X	Nozzle - 1.0 mm long w/radius CP	1
	PT390-0005CP		L1375X	Nozzle - 1.2 mm long w/radius CP	1
	PT390-0006CP		L1376X	Nozzle - 1.5 mm long w/radius CP	1
	PT390-0009CP		L1373X	Nozzle - 1.8 mm long w/radius CP	1
	PT390-0007CP		L1377X	Nozzle - 2.0 mm long w/radius CP	1
	PT390-0008CP		L1378X	Nozzle - 2.5 mm long w/radius CP	1

For Adige, Finn Power and GHT systems

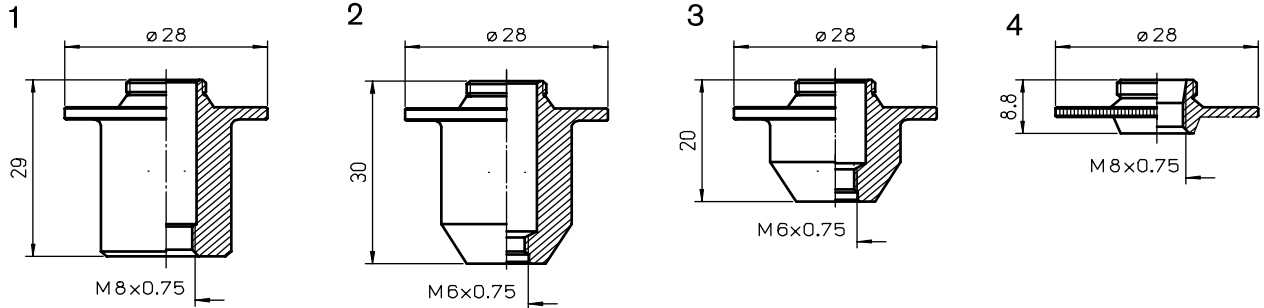

Consumables

	Centricut part number	Reference number	Alternate reference	Description	Pkg qty
1	PT406-0333		AL333	Nozzle adapter L - 29 M8	1
2	PT406-0334		AL334	Nozzle adapter L - 30 M6	1
3	PT406-0335		AL335	Nozzle adapter L - 20 M6	1
4	PT406-0043	Centricut design	AL43	Nozzle adapter	1

For Koike systems

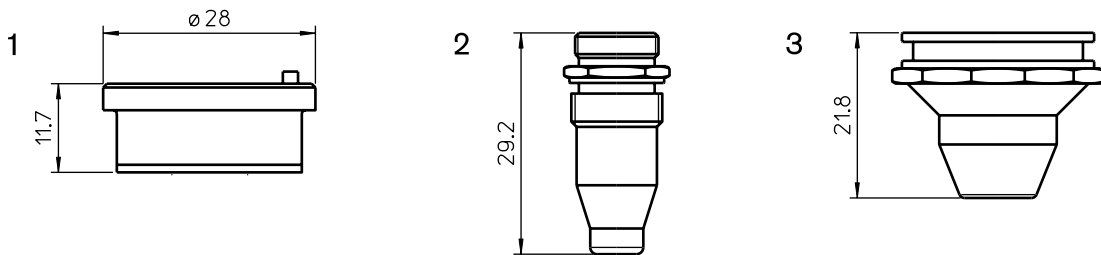

Consumables

	Centricut part number	Reference number	Alternate reference	Description	Pkg qty
1	PT348-1330OEM	281330, P0571-260-00001	AL23	Nozzle holder KT B2 - OEM	1
	PT348-1330	281330, P0571-260-00001	AL131	Nozzle holder KT B2	1
	PT348-1051	P0571-1051-00001	AL355	Nozzle holder KT B2 CON - OEM	1
2	PT348-4175	20054175	L1547	Inner nozzle - 1.9 mm	1
3	PT348-4176	20054176	AL415	Outer nozzle - 8.0 mm	1

For Adige, Durma, Ermaksan, Finn Power, GHT, Hans, Mazak, SHT and Salvagnini systems

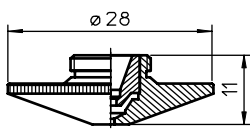

1

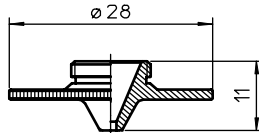

2

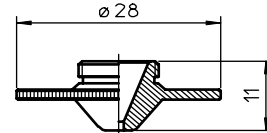

3

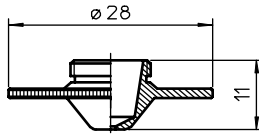
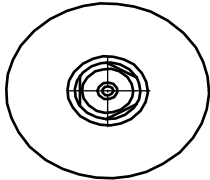

4

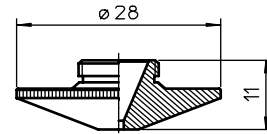

5

Consumables

	Centricut part number	Reference number	Alternate reference	Description	Pkg qty
1	PT377-0001	Centricut design	L1179	Nozzle - 1.0 mm double	1
	PT377-0002	Centricut design	L1180	Nozzle - 1.5 mm double	1
	PT377-0003	Centricut design	L1181	Nozzle - 2.0 mm double	1
	PT377-0004	Centricut design	L1182	Nozzle - 2.5 mm double	1
	PT377-0005	Centricut design	L1183	Nozzle - 3.0 mm double	1
	PT377-0001CP	Centricut design	L1179X	Nozzle - 1.0 mm double CP	1
	PT377-0002CP	Centricut design	L1180X	Nozzle - 1.5 mm double CP	1
	PT377-0003CP	Centricut design	L1181X	Nozzle - 2.0 mm double CP	1
	PT377-0004CP	Centricut design	L1182X	Nozzle - 2.5 mm double CP	1
	PT377-0005CP	Centricut design	L1183X	Nozzle - 3.0 mm double CP	1
2	PT348-0001		L1218	Nozzle - 1.5 mm HD	1
	PT348-0002		L1219	Nozzle - 2.0 mm HD	1
	PT348-0003		L1220	Nozzle - 2.5 mm HD	1
	PT348-0001CP		L1218X	Nozzle - 1.5 mm HD CP	1
	PT348-0002CP		L1219X	Nozzle - 2.0 mm HD CP	1
	PT348-0003CP		L1220X	Nozzle - 2.5 mm HD CP	1
3	PT348-0015		L1062	Nozzle - 1.5 mm HD	1
	PT348-0020		L1063	Nozzle - 2.0 mm HD	1
	PT348-0025		L1064	Nozzle - 2.5 mm HD	1
	PT348-0030		L1065	Nozzle - 3.0 mm HD	1
4	PT348-1340	281340, P0571-281-00010	L410	Nozzle - 1.0 mm	1
	PT348-1341	281341, P0571-282-00012	L411	Nozzle - 1.2 mm	1
	PT348-1342	281342, P0571-283-00015	L412	Nozzle - 1.5 mm	1
	PT348-0018	281342, P0571-284-00018	L413	Nozzle - 1.8 mm	1
	PT348-1343	281343, P0571-285-00020	L414	Nozzle - 2.0 mm	1
	PT348-1344	281344, P0571-286-00025	L415	Nozzle - 2.5 mm	1
5	PT377-0010	281599, P0571-291-00010	L465	Nozzle - 1.0 mm	1
	PT377-0012	P0571-292-00012	L466	Nozzle - 1.2 mm	1
	PT377-0015	281570, P0571-293-00015	L467	Nozzle - 1.5 mm	1
	PT377-0018		L468	Nozzle - 1.8 mm	1
	PT377-0020	281571, P0571-295-00020	L469	Nozzle - 2.0 mm	1
	PT377-0025	281572, P0571-297-00025	L470	Nozzle - 2.5 mm	1
	PT377-0030		L463	Nozzle - 3.0 mm	1

Centricut is a registered trademark of Hypertherm Inc. and may be registered in the United States and/or other countries. All other trademarks are the properties of their respective owners. Centricut is in no way affiliated with Precitec.

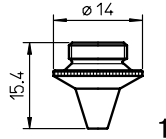

1

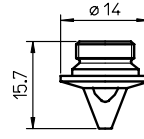

2

Consumables

	Centricut part number	Reference number	Alternate reference	Description	Pkg qty
AKK52 – AKH27 – YH27 – YR30 Sensor system					
1	PT344-1813	281813, P0589-424-00008	L405	Nozzle – 0.8 mm	1
	PT344-1813X	281813, P0589-424-00008	L30405	Nozzle – 0.8 mm (10 pack)	10
	PT344-1789	281789, P0589-426-00010	L406	Nozzle – 1.0 mm	1
	PT344-1789X	281789, P0589-426-00010	L30406	Nozzle – 1.0 mm (10 pack)	10
	PT344-1561	281561, 778550	L404	Nozzle – 1.2 mm	1
	PT344-1561X	281561, 778550	L30404	Nozzle – 1.2 mm (10 pack)	10
	PT344-1499	281814, 149957	L407	Nozzle – 1.5 mm	1
	PT344-1499X	281814, 149957	L30407	Nozzle – 1.5 mm (10 pack)	10
	PT344-0020	P0589-428-00020	L408	Nozzle – 2.0 mm	1
	PT344-0020X	P0589-428-00020	L30408	Nozzle – 2.0 mm (10 pack)	10
	PT344-1791 NEW	281791		Nozzle – 2.5 mm	1
	PT344-1813CP	281813, P0589-424-00008	L405X	Nozzle – 0.8 mm CP	1
	PT344-1813CPX	281813, P0589-424-00008	L30405X	Nozzle – 0.8 mm CP (10 pack)	10
	PT344-1789CP	281789, P0589-426-00010	L406X	Nozzle – 1.0 mm CP	1
	PT344-1789CPX	281789, P0589-426-00010	L30406X	Nozzle – 1.0 mm CP (10 pack)	10
	PT344-1561CP	281561, 778550, P0589-425-00012	L404X	Nozzle – 1.2 mm CP	1
	PT344-1561CPX	281561, 778550	L30404X	Nozzle – 1.2 mm CP (10 pack)	10
	PT344-1499CP	281814, 149957	L407X	Nozzle – 1.5 mm CP	1
	PT344-1499CPX	281814, 149957	L30407X	Nozzle – 1.5 mm CP (10 pack)	10
	PT344-0020CP	P0589-428-00020	L408X	Nozzle – 2.0 mm CP	1
PT344-0020CPX	P0589-428-00020	L30408X	Nozzle – 2.0 mm CP (10 pack)	10	
YK52 Sensor system					
2	PT391-0010	281498, P0587-722-00010	L800	Nozzle – 1.0 mm	1
	PT391-0010X	281498, P0587-722-00010	L30800	Nozzle – 1.0 mm (10 pack)	10
	PT391-0012	P0587-723-00012	L801	Nozzle – 1.2 mm	1
	PT391-0012X	P0587-723-00012	L30801	Nozzle – 1.2 mm (10 pack)	10
	PT391-0015	281497, P0587-721-00015	L802	Nozzle – 1.5 mm	1
	PT391-0015X	281497, P0587-721-00015	L30802	Nozzle – 1.5 mm (10 pack)	10
	PT391-0018	281516, P0587-737-00018	L803	Nozzle – 1.8 mm	1
	PT391-0018X	281516, P0587-737-00018	L30803	Nozzle – 1.8 mm (10 pack)	10
	PT391-0020	281567, P0587-771-00020	L804	Nozzle – 2.0 mm	1
	PT391-0020X	281567, P0587-771-00020	L30804	Nozzle – 2.0 mm (10 pack)	10
	PT391-0025	P0587-772-00025	L805	Nozzle – 2.5 mm	1
	PT391-0025X	P0587-772-00025	L30805	Nozzle – 2.5 mm (10 pack)	10

For Adige, Finn Power and GHT systems

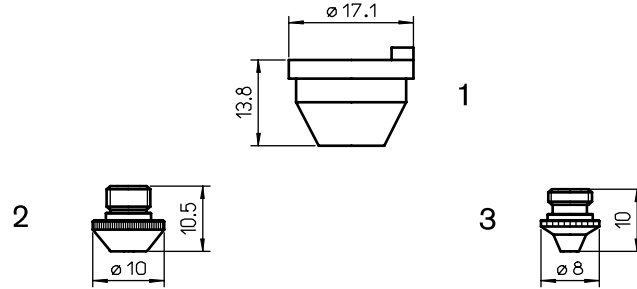

Consumables

	Centricut part number	Reference number	Alternate reference	Description	Pkg qty
5" KN Sensor system					
1	TR302-2405	280408, 092405	AL53	Nozzle holder – KTM 1.5" KN	1
2	PT344-0551	280551, P0494-853-00010	L292	Nozzle – 1.0 mm	1
	PT344-0551X	280551, P0494-853-00010	L30292	Nozzle – 1.0 mm (10 pack)	10
	PT344-0552	280552, P0494-854-00012	L293	Nozzle – 1.2 mm	1
	PT344-0552X	280552, P0494-854-00012	L30293	Nozzle – 1.2 mm (10 pack)	10
	PT344-0553	280553, P0494-855-00015	L294	Nozzle – 1.5 mm	1
	PT344-0553X	280553, P0494-855-00015	L30294	Nozzle – 1.5 mm (10 pack)	10
	PT344-0554	280554, P0494-856-00017	L295	Nozzle – 1.7 mm	1
	PT344-0554X	280553, P0494-856-00017	L30295	Nozzle – 1.7 mm (10 pack)	10
	PT344-0555	280555, P0494-855-00020	L296	Nozzle – 2.0 mm	1
	PT344-0555X	280553, P0494-855-00015	L30296	Nozzle – 2.0 mm (10 pack)	10
	PT344-9023		L372	Nozzle – 2.3 mm	1
	PT344-9023X		L30372	Nozzle – 2.3 mm (10 pack)	10
	PT344-9025		L371	Nozzle – 2.5 mm	1
	PT344-9025X		L30371	Nozzle – 2.5 mm (10 pack)	10
	PT344-0030		L304	Nozzle – 3.0 mm	1
	PT344-0030X		L30304	Nozzle – 3.0 mm (10 pack)	10
	PT344-0400		L303	Nozzle – 4.0 mm	1
	PT344-0400X		L30303	Nozzle – 4.0 mm (10 pack)	10
DEM 1.5"					
3	PT379-0010	280943, P0494-787-00010	L1055	Nozzle – 1.0 mm KN	1
	PT379-0010X	280943, P0494-787-00010	L301055	Nozzle – 1.0 mm KN (10 pack)	10
	PT379-0012	280942, P0494-788-00012	L1056	Nozzle – 1.2 mm KN	1
	PT379-0012X	280942, P0494-788-00012	L301056	Nozzle – 1.2 mm KN (10 pack)	10
	PT379-0015	280941, P0494-789-00015	L1057	Nozzle – 1.5 mm KN	1
	PT379-0015X	280941, P0494-789-00015	L301057	Nozzle – 1.5 mm KN (10 pack)	10
	PT379-0018		L1058	Nozzle – 1.8 mm KN	1
	PT379-0018X		L301058	Nozzle – 1.8 mm KN (10 pack)	10
	PT379-0020		L1059	Nozzle – 2.0 mm KN	1
	PT379-0020X		L301059	Nozzle – 2.0 mm KN (10 pack)	10

For Adige, Finn Power and GHT systems

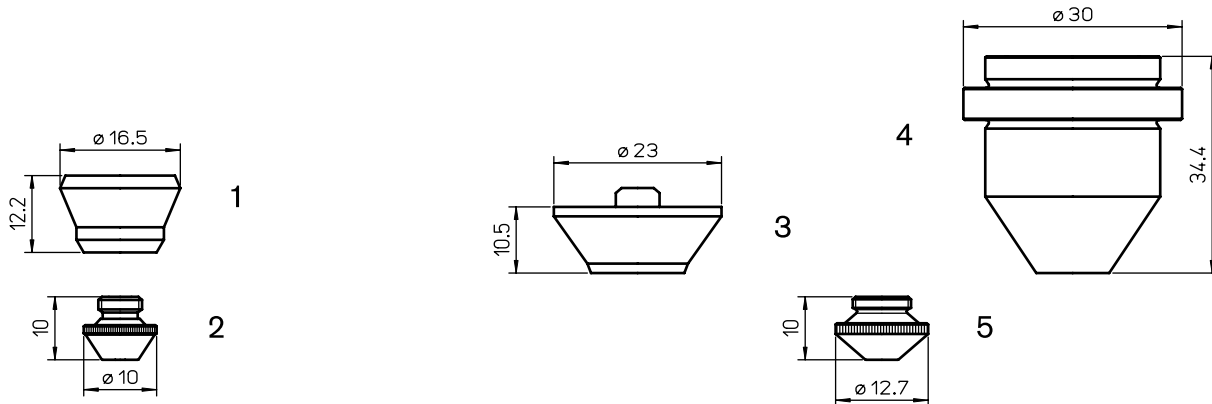

Consumables

	Centricut part number	Reference number	Alternate reference	Description	Pkg qty
5" K SENSOR SYSTEM					
1	PT344-0040	280040, P0492-752-00001	AL67	Nozzle holder – KT M1.5" K OEM	1
2	PT344-0048	280048, P0492-853-00010	L350	Nozzle – 1.0 mm	1
	PT344-0048X	280048, P0492-853-00010	L30350	Nozzle – 1.0 mm (10 pack)	10
	PT344-0049	280049, P0492-854-00012	L351	Nozzle – 1.2 mm	1
	PT344-0049X	280049, P0492-854-00012	L30351	Nozzle – 1.2 mm (10 pack)	10
	PT344-0050	280050, P0492-855-00015	L352	Nozzle – 1.5 mm	1
	PT344-0050X	280050, P0492-855-00015	L30352	Nozzle – 1.5 mm (10 pack)	10
	PT344-0051	280050	L353	Nozzle – 2.0 mm	1
	PT344-0051X	280050	L30353	Nozzle – 2.0 mm (10 pack)	10
2.5" CM SENSOR SYSTEM					
3	PT344-1079	281079, P0492-430-00003, W149	AL138	Nozzle holder – OEM KTM1.5" S F2.5"	1
4	PT347-0100		AL352	Nozzle holder – aluminum	1
5	PT344-0013	280013, P0492-441-00008, W222	L400	Nozzle – 0.8 mm	1
	PT344-0013X	280013, P0492-441-00008	L30400	Nozzle – 0.8 mm (10 pack)	10
	PT344-0014	280014, P0492-442-00010, W223	L401	Nozzle – 1.0 mm	1
	MB336-223X	280014, P0492-442-00010, W223	L30401	Nozzle – 1.0 mm (10 pack)	10
	PT344-0015	280015, P0492-443-00012, W228	L402	Nozzle – 1.2 mm	1
	PT344-0015X	280015, P0492-443-00012	L30402	Nozzle – 1.2 mm (10 pack)	10
	MB336-224	280016, P0492-444-00015, W224	L403	Nozzle – 1.5 mm	1
	MB336-224X	280016, P0492-444-00015, W224	L30403	Nozzle – 1.5 mm (10 pack)	10
	PT344-0018	P0492-447-00018	L543	Nozzle – 1.8 mm	1
	PT344-0018X	P0492-447-00018	L30543	Nozzle – 1.8 mm (10 pack)	10
	MB336-225	280937, P0492-445-00020, W225	L544	Nozzle – 2.0 mm	1
	MB336-225X	280937, P0492-445-00020, W225	L30544	Nozzle – 2.0 mm (10 pack)	10
	PT344-0023	P0492-448-00023	L546	Nozzle – 2.3 mm	1
	PT344-0023X	P0492-448-00023	L30546	Nozzle – 2.3 mm (10 pack)	10
	MB336-226	281791, P0492-446-00025, W226	L545	Nozzle – 2.5 mm	1
	MB336-226X	281791, P0492-446-00025, W226	L30545	Nozzle – 2.5 mm (10 pack)	10
	MB336-0005		L547	Nozzle – 3.0 mm	1
	MB336-0005X		L30547	Nozzle – 3.0 mm (10 pack)	10
	PT344-0008CP	280013, P0492-441-00008	L400X	Nozzle – 0.8 mm CP	1
	PT344-0008CPX	280013, P0492-441-00008	L30400X	Nozzle – 0.8 mm CP (10 pack)	10
	PT344-0010CP	280014, P0492-442-00010, W223	L401X	Nozzle – 1.0 mm CP	1
	PT344-0010CPX	280014, P0492-442-00010, W223	L30401X	Nozzle – 1.0 mm CP (10 pack)	10
	PT344-0012CP		L402X	Nozzle – 1.2 mm CP	1
	PT344-0012CPX		L30402X	Nozzle – 1.2 mm CP (10 pack)	10
	PT344-0015CP	280016, P0492-444-00015, W224	L403X	Nozzle – 1.5 mm CP	1
	PT344-0015CPX	280016, P0492-444-00015, W224	L30403X	Nozzle – 1.5 mm CP (10 pack)	10

Consumables

	Centricut part number	Reference number	Alternate reference	Description	Pkg qty
5	PT344-0018CP	P0492-447-00018	L543X	Nozzle - 1.8 mm CP	1
	PT344-0018CPX	P0492-447-00018	L30543X	Nozzle - 1.8 mm CP (10 pack)	10
	PT344-0022CP	280937, P0492-445-00020, W225	L544X	Nozzle - 2.0 mm CP	1
	PT344-0022CPX	280937, P0492-445-00020, W225	L30544X	Nozzle - 2.0 mm CP (10 pack)	10
	PT344-0023CP	P0492-448-00023	L546X	Nozzle - 2.3 mm CP	1
	PT344-0023CPX	P0492-448-00023	L30546X	Nozzle - 2.3 mm CP (10 pack)	10
	PT344-0025CP	281791, P0492-446-00025, W226	L545X	Nozzle - 2.5 mm CP	1
	PT344-0025CPX	281791, P0492-446-00025, W226	L30545X	Nozzle - 2.5 mm CP (10 pack)	10
	PT344-0027CP		L547X	Nozzle - 3.0 mm CP	1
	PT344-0027CPX		L30547X	Nozzle - 3.0 mm CP (10 pack)	10

For Adige and Mazak systems

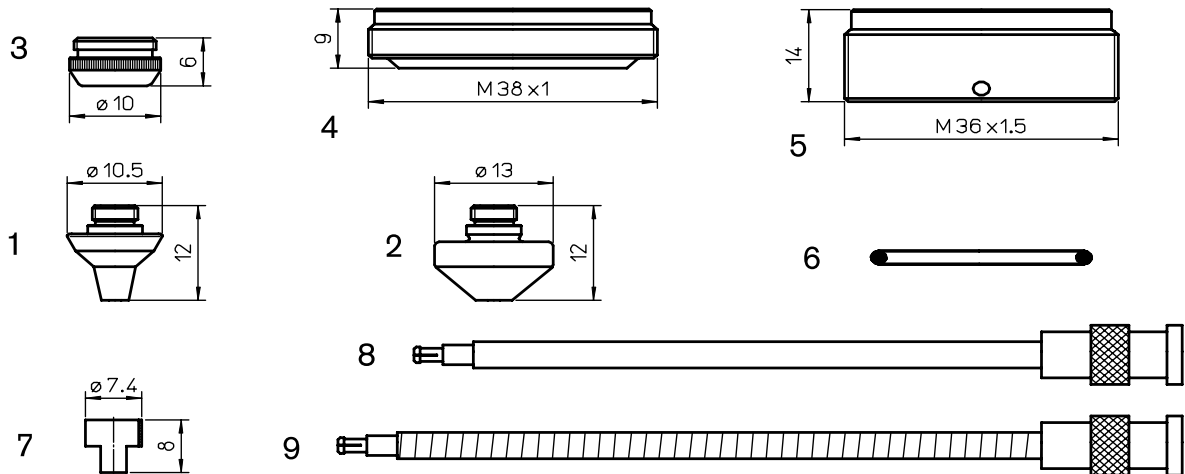

MAZAK 3D – Precitec 5"C/MG – 5"H/MG

Consumables

	Centricut part number	Reference number	Alternate reference	Description	Pkg qty
1	PT347-0005	46713300290-10	L554	Nozzle - 1.0 mm 3D	1
	PT347-0005X	46713300290-10	L30554	Nozzle - 1.0 mm 3D (10 pack)	10
	PT347-0290-1.2	46713300290-12	L555	Nozzle - 1.2 mm 3D	1
	PT347-0090X	46713300290-12	L30555	Nozzle - 1.2 mm 3D (10 pack)	10
	PT347-0290	46713300290-15, P0352-381-00015	L556	Nozzle - 1.5 mm 3D	1
	PT347-0290X	46713300290-15, P0352-381-00015	L30556	Nozzle - 1.5 mm 3D (10 pack)	10
	PT347-0118		L557	Nozzle - 1.8 mm 3D	1
	PT347-0118X		L30557	Nozzle - 1.8 mm 3D (10 pack)	10
	PT347-0280	46713300310, P0352-382-00020	L558	Nozzle - 2.0 mm 3D	1
	PT347-0280X	46713300310, P0352-382-00020	L30558	Nozzle - 2.0 mm 3D (10 pack)	10
	PT347-0001	46713300280-25	L560	Nozzle - 2.5 mm 3D	1
	PT347-0001X	46713300280-25	L30560	Nozzle - 2.5 mm 3D (10 pack)	10
	PT347-0002	46713300280-30, 46713300430	L563	Nozzle - 3.0 mm 3D	1
	PT347-0002X	46713300280-30	L30563	Nozzle - 3.0 mm 3D (10 pack)	10
PT347-0035	46713300280-35	L564	Nozzle - 3.5 mm 3D	1	
PT347-0035X	46713300280-35	L30564	Nozzle - 3.5 mm 3D (10 pack)	10	
2	PT347-0004		L576	Nozzle - 1.0 mm 2D	1
	PT347-0004X		L30576	Nozzle - 1.0 mm 2D (10 pack)	10
	PT347-0310-1.2	46713300310	L577	Nozzle - 1.2 mm 2D	1
	PT347-0012X	46713300310	L30577	Nozzle - 1.2 mm 2D (10 pack)	10
	PT347-0310	P0352-386-00015	L578	Nozzle - 1.5 mm 2D	1
	PT347-0310X	P0352-386-00015	L30578	Nozzle - 1.5 mm 2D (10 pack)	10
	PT347-1018		L579	Nozzle - 1.8 mm 2D	1
	PT347-1018X		L30579	Nozzle - 1.8 mm 2D (10 pack)	10
	PT347-0300	46713300300, P0352-387-00020	L580	Nozzle - 2.0 mm 2D	1
	PT347-0300X	46713300300, P0352-387-00020	L30580	Nozzle - 2.0 mm 2D (10 pack)	10
	PT347-0003	46713300300-25	L581	Nozzle - 2.5 mm 2D	1
	PT347-0003X	46713300300-25	L30581	Nozzle - 2.5 mm 2D (10 pack)	10
PT347-0006	46713300300-30	L582	Nozzle - 3.0 mm 2D	1	
PT347-0006X	46713300300-30	L30582	Nozzle - 3.0 mm 2D (10 pack)	10	
3	PT347-0320	46713300321, P0352-311-00001	AL160	Union nut - Vespel®	1
4	PT347-4297	P0492-702-00001, 29100021	AL198	Insulating ring	1
5	PT347-0008	46713330200	AL218	Insulator 5-axis	1
6	AM326-6453	71366453	AL94	Outer nozzle o-ring	1
7	PT347-0009		AL256	Insulator collar	1
8	PT347-0101	P0360-100-00500, 46713300100	AL204	Sensor cable 500 mm (DEM)	1
9	PT347-1386	281386, P0360-155-00500	AL257	Sensor cable - armored	1

Centricut is a registered trademark of Hypertherm Inc. and may be registered in the United States and/or other countries. All other trademarks are the properties of their respective owners. Centricut is in no way affiliated with Precitec.

For Adige and Mazak systems

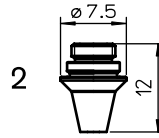
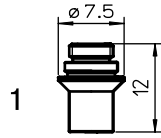

Consumables

	Centricut part number	Reference number	Alternate reference	Description	Pkg qty
1	PT347-1005	281005, P0352-323-00010	L480	Nozzle - 1.0 mm ZK	1
	PT347-1005X	281005, P0352-323-00010	L30480	Nozzle - 1.0 mm ZK (10 pack)	10
	PT347-1034	281034, P0352-324-00012	L481	Nozzle - 1.2 mm ZK	1
	PT347-1034X	281034, P0352-324-00012	L30481	Nozzle - 1.2 mm ZK (10 pack)	10
	PT347-1013	281013, P0352-325-00015	L482	Nozzle - 1.5 mm ZK	1
	PT347-1013X	281013, P0352-325-00015	L30482	Nozzle - 1.5 mm ZK (10 pack)	10
	PT347-0899	280899, P0352-326-00018	L483	Nozzle - 1.8 mm ZK	1
	PT347-0899X	280899, P0352-326-00018	L30483	Nozzle - 1.8 mm ZK (10 pack)	10
	PT347-0044-3	350044.3, P0352-327-00020	L484	Nozzle - 2.0 mm ZK	1
	PT347-0044X	350044.3, P0352-327-00020	L30484	Nozzle - 2.0 mm ZK (10 pack)	10
	PT347-1025	P0352-328-00025	L485	Nozzle - 2.5 mm ZK	1
	PT347-1025X	350044.3, P0352-328-00025	L30485	Nozzle - 2.5 mm ZK (10 pack)	10
	2	PT347-1006	281006, P0352-333-00010	L486	Nozzle - 1.0 mm KK
PT347-1006X		281006, P0352-333-00010	L30486	Nozzle - 1.0 mm KK (10 pack)	10
PT347-1030		281030, P0352-334-00012	L487	Nozzle - 1.2 mm KK	1
PT347-1030X		281030, P0352-334-00012	L30487	Nozzle - 1.2 mm KK (10 pack)	10
PT347-1031		281031, P0352-335-00015	L488	Nozzle - 1.5 mm KK	1
PT347-1031X		281031, P0352-335-00015	L30488	Nozzle - 1.5 mm KK (10 pack)	10
PT347-0898		280898, P0352-336-00018	L489	Nozzle - 1.8 mm KK	1
PT347-0898X		280898, P0352-336-00018	L30489	Nozzle - 1.8 mm KK (10 pack)	10
PT347-1020		P0352-336-00020	L490	Nozzle - 2.0 mm KK	1
PT347-1020X		P0352-336-00020	L30490	Nozzle - 2.0 mm KK (10 pack)	10

For Adige and Finn-Power systems

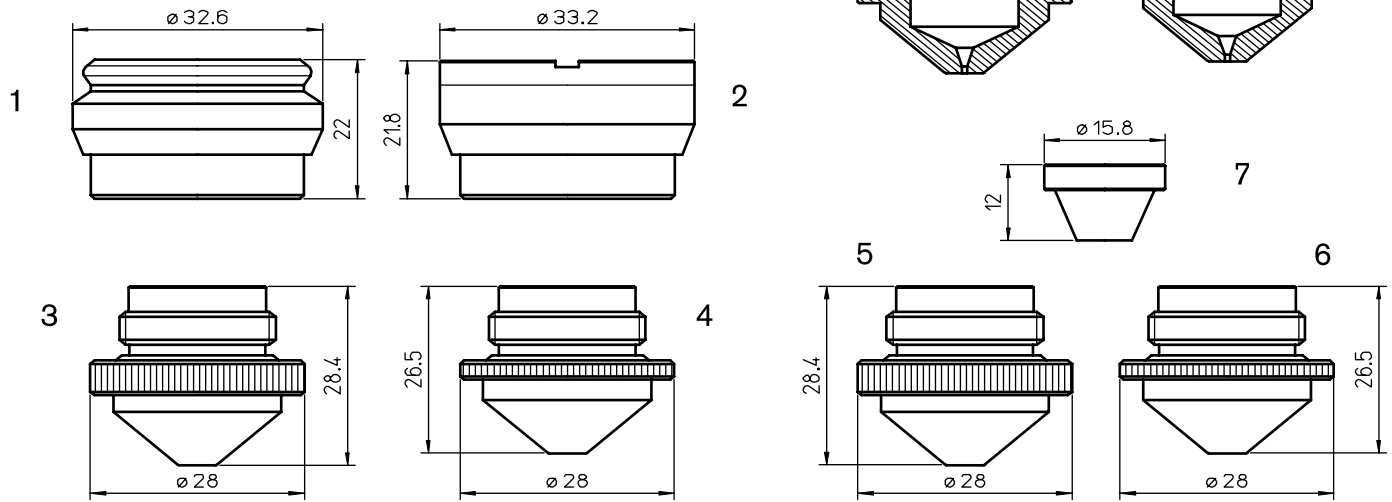

5"DX – 5" DXN PRECITEC SENSOR SYSTEM

Consumables

	Centricut part number	Reference number	Alternate reference	Description	Pkg qty
1	PT311-0831	280831, P0492-622-00002	AL35	Nozzle holder – KT A1.5"DX – ceramic	1
2	PT311-0565		AL40	Nozzle holder – KT A1.5"DXN – ceramic	1
3	PT311-0002		L87	Nozzle – 0.8 mm	1
	PT311-0110		L10	Nozzle – 1.25 mm	1
4	PT311-0004		L90	Nozzle – 1.5 mm	1
	PT311-0005		L40	Nozzle – 1.5 mm HD	1
	PT311-0006		L186	Nozzle – 1.8 mm HD	1
5	PT311-0007	Centricut design	L187	Nozzle – 0.8 mm	1
	PT311-0008	Centricut design	L188	Nozzle – 1.25 mm	1
	PT311-0009	Centricut design	L189	Nozzle – 1.5 mm	1
6	PT311-1010	Centricut design	L190	Nozzle – 1.5 mm	1
	PT311-0011	Centricut design	L191	Nozzle – 1.8 mm	1
7	LV418-0001	Centricut design	L157	Nozzle, inner	1

For Adige and Finn-Power systems

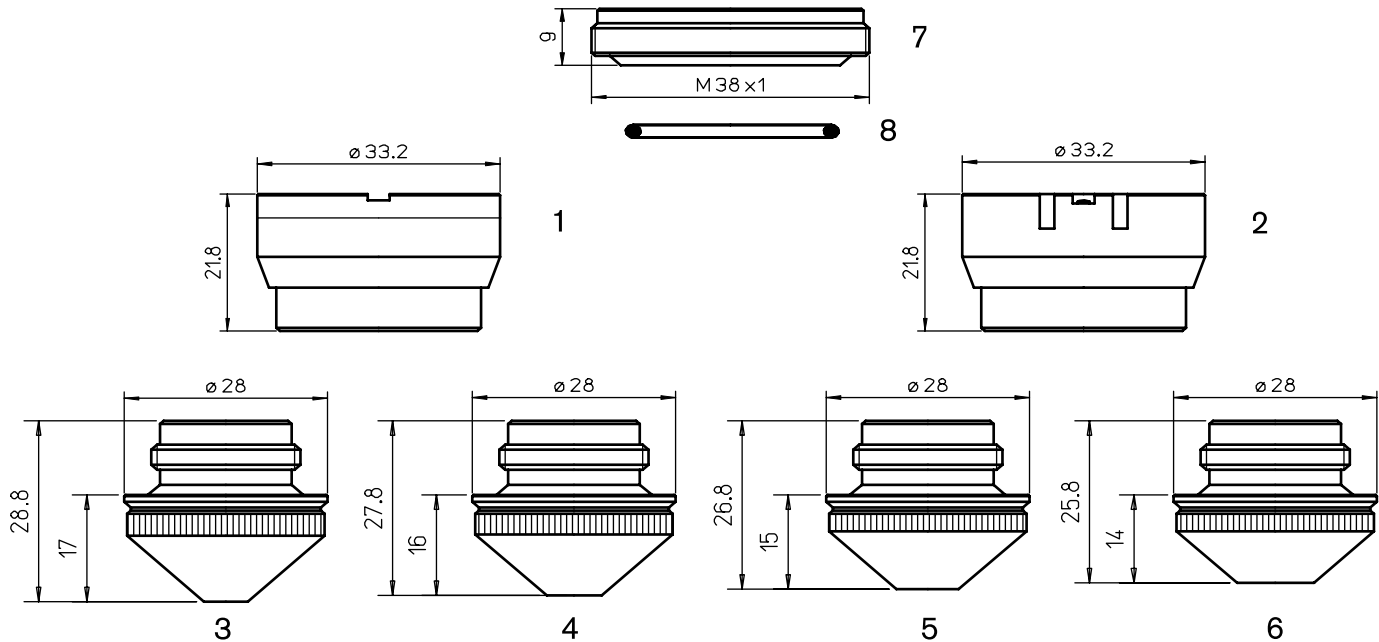

5" DXN – 5" DL SENSOR SYSTEM

Consumables

	Centricut part number	Reference number	Alternate reference	Description	Pkg qty
1	PT311-0565	280565, P0497-605-00001, 29100106	AL40	Nozzle holder – KTM 1.5" DXN – ceramic	1
2	PT311-1146	281146, P0380-211-00001, 29100033	AL130/S	Nozzle holder – ITM 1.5" DZ	1
	PT311-1146 OEM	281146, P0380-211-00001, 29100033	AL130	Nozzle holder – ITM 1.5" DZ (OEM) – aluminum	1
3	PT376-0010	280029, P0492-628-00010	L365	Nozzle – 1.0 mm	1
	PT376-0012	280030, P0492-629-00012	L366	Nozzle – 1.2 mm	1
4	PT376-0015	280028, P0492-627-00015	L367	Nozzle – 1.5 mm	1
5	PT376-0017	281384, P0492-630-00017	L368	Nozzle – 1.7 mm	1
	PT376-0020	280027, P0492-626-00020	L369	Nozzle – 2.0 mm	1
6	PT376-0025	280026, P0492-625-00025	L370	Nozzle – 2.5 mm	1
7	PT311-0001	P0492-702-00002	AL201	Insulating ring – plastic	1
8	AM326-6453	71366453	AL94	Outer nozzle o-ring	1

For Adige and Finn-Power systems

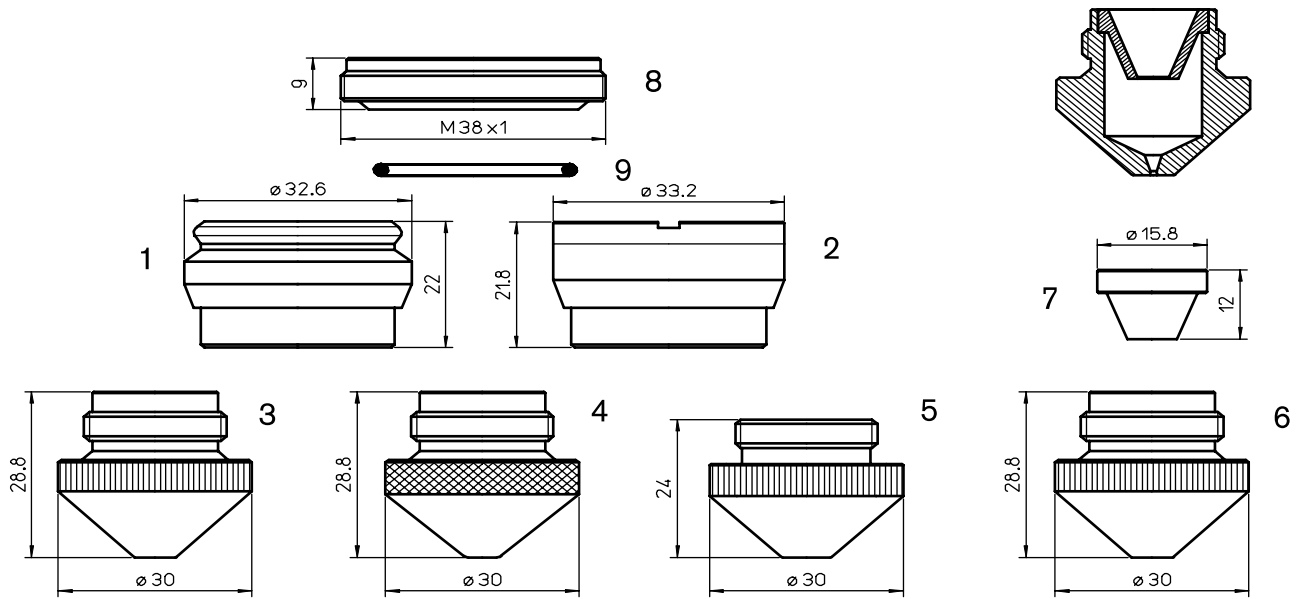

5"DX e 5"DXN PRECITEC SENSOR SYSTEM

Consumables

	Centricut part number	Reference number	Alternate reference	Description	Pkg qty
1	PT311-0831	280831, P0492-622-00002	AL35	Nozzle holder - KT A1.5"DX - ceramic	1
2	PT311-0565	280565, P0497-605-00001, 29100106	AL40	Nozzle holder - KTM 1.5" DXN - ceramic	1
3	PT311-0010	281253, P0380-251-00010	L163	Nozzle - 1.0 mm	1
	PT311-0012	281254, P0380-252-00012	L164	Nozzle - 1.2 mm	1
	PT311-0015	281255, P0380-253-00015	L165	Nozzle - 1.5 mm	1
	PT311-0020	281270, P0380-254-00020	L166	Nozzle - 2.0 mm	1
	PT311-0025	281271, P0380-255-00025	L167	Nozzle - 2.5 mm	1
	PT311-0027	281271-2.7	L462	Nozzle - 2.7 mm	1
	PT311-0030	281271-3.0	L201	Nozzle - 3.0 mm	1
4	BA372-0405		L887	Nozzle - 1.5 mm	1
5	PT311-0013	281029L	L921	Nozzle - 1.0 mm	1
	PT311-0014		L920	Nozzle - 2.0 mm (w/counter bore)	1
6	PT311-1002	Centricut design	L259	Nozzle - 1.0 mm HD	1
	PT311-0003	Centricut design	L260	Nozzle - 1.2 mm HD	1
	PT311-1004	Centricut design	L261	Nozzle - 1.5 mm HD	1
	PT311-1005	Centricut design	L262	Nozzle - 2.0 mm HD	1
	PT311-1006	Centricut design	L263	Nozzle - 2.5 mm HD	1
	PT311-1007	Centricut design	L264	Nozzle - 3.0 mm HD	1
7	LV418-0001	Centricut design	L157	Nozzle, inner	1
8	PT311-0001	P0492-702-00002	AL201	Insulating ring - plastic	1
9	AM326-6453	71366453	AL94	Outer nozzle o-ring	1

Consumables

Centricut part number	Reference number	Alternate reference	Description	Pkg qty
PRECITEC® original spare parts (Not shown)				
PT347-0007 NEW	P0354-110-00001	AL211	OEM nozzle body SE M1.5" HNZ	1
PT347-0010	P059110500001		Connector head OEM	1
PT347-0012	P049713000001		Nut M1.5" DXN OEM	1
PT347-0200	P049700200200		Cable 200 mm OEM	1
PT347-0000	P0251107000001	OG Y D50 d2 HII	Protecting glass	1
PT347-0014	P036015000300	KE 300 gw Z mm	Sensor cable OEM	1
PT347-0016	P059177000001		Electrode tacitile OEM	1
PT347-0017	P059132900001	ZM HP1.5" DR	Seal 1.5" OEM	1
PT347-0018	P08M00001124KF	ZM HP1.5" DF	Seal 1.5" OEM	1
PT347-0021	P059451000001		Sensor SE HP 2.0" OEM	1
PT347-0022	P059158000001	281617	Socket ZM HP 1.5" IB OEM	1
PT347-0023	P059192000001	281395	Seals (set) ZM HP1.5" DS OEM	1
PT347-0024 NEW	P0497-110-00001		Sensor insert – SE M1.5DXN	1
PT347-1439	P0591-360-0001		Lens ring set	1
PT347-1383	P0591-490-0001	281395	Nut tray	1
PT344-0001	P0788-580-00001		Lens mount – 0L YR30 F100 w/lens	1
PT347-0130	P0492-001-00130		Electrode cable, KE 130 GW	1
PT347-0220	P0464-810-00220		Electrode cable, KE 220 GGMM	1
PT347-350		AL350	Washer for cone	1
PT347-349		AL349	Inner sensor cone	1

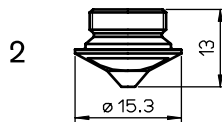
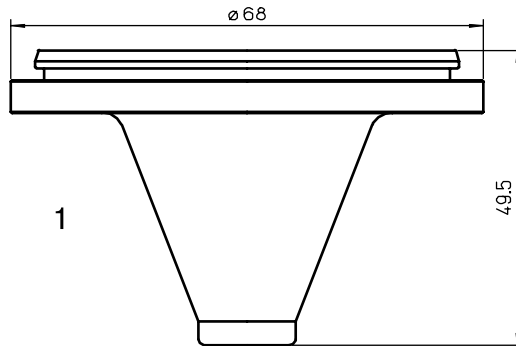

ZE SE YK 52 Z

Consumables

	Centricut part number	Reference number	Alternate reference	Description	Pkg qty
1	PT401-0001	P0587-440-00001	AL244	Nozzle holder – YKZ	1
	PT401-1008	P0587-842-00008	L1012	Nozzle – 0.8 mm	1
2	PT401-0010	P0587-841-00010	L1013	Nozzle – 1.0 mm	1
	PT401-0015	P0587-846-00015	L1014	Nozzle – 1.5 mm	1
	PT347-0000 (not shown)	P251107000001	OG Y D50 d2 HII	Protecting glass	1

For Adige, Durma, Ermakson, Finn Power, GHT, Hans, Mazak, SHT and Salvagnini systems

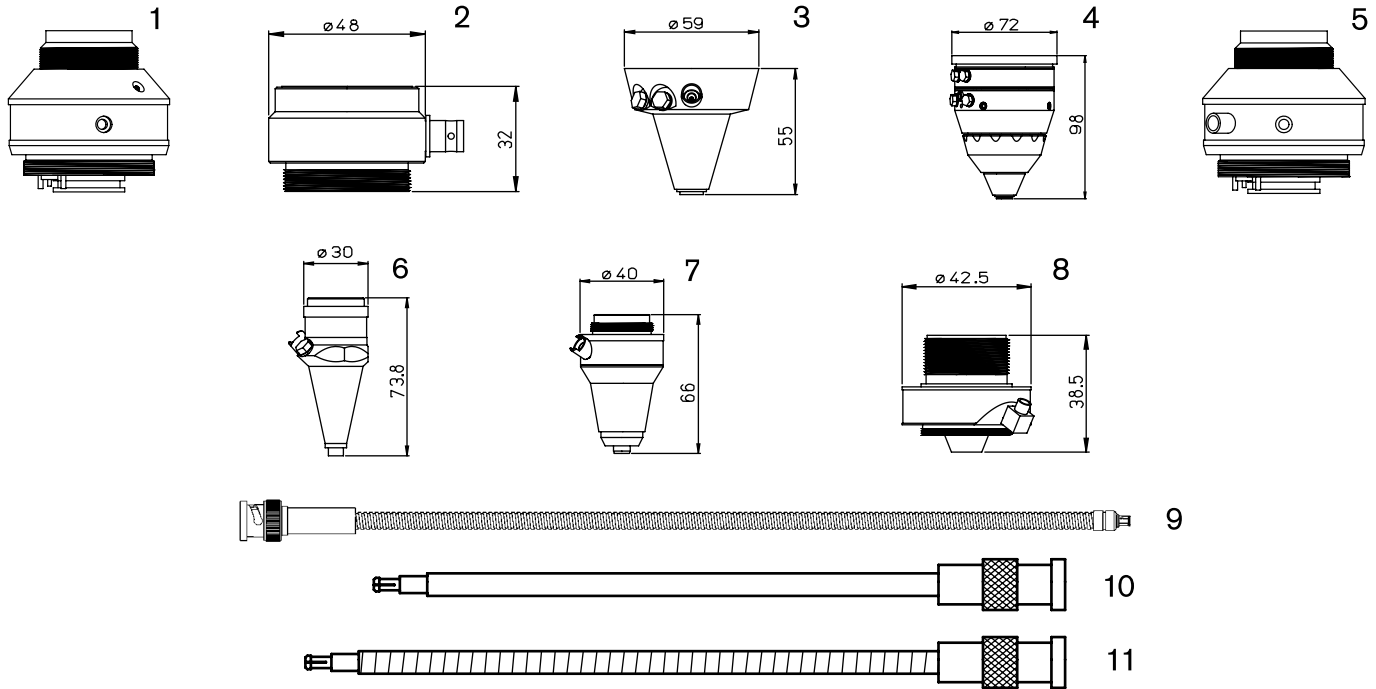

Consumables

	Centricut part number	Reference number	Alternate reference	Description	Pkg qty
Sensor cone repair					
1	PT999-DXN			Sensor repair DXN	
2	MB999-429A	W429A	461	Sensor repair W429A	1
3	PT999-YH27	P0589-800-00001		Sensor repair YH27	1
4	PT999-YR30	YR-30		Sensor repair YR-30	1
5	PT999-DZ	281145		Sensor repair DZ	1
6	PT999-HNZ	P0354-110-00001		Sensor repair HNZ	1
	PT999-HPZ (not shown)			Sensor repair HPZ	1
7	PT999-KN	280549		Sensor repair KN	1
	PT420-0125 (not shown)			Sensor repair S.5J	1
8	PT999-25ZJ	P0361-203-00001		Sensor repair 25ZJ	1
	MB999-239	W239		Sensor repair W239	1
	PT999-HP2 (not shown)	281672		Sensor repair HP/HP2Z	1
New sensor cones					
8	PT347-8001 NEW	280010		Sensor cone - 2.5Z/J	1
	PT347-0522 (not shown) NEW	P0599-520-00002		Sensor cone - LRC	1
Sensor cables					
9	PT347-0101A	P0360-100-00500		Sensor cable - armored 500 mm (20")	1
	PT347-0250 (not shown)	P0492-001-00250		Sensor cable - armored 250 mm (10")	1
10	PT347-0101	P0360-100-00500, 46713300100	AL204	Sensor cable 500 mm (OEM) (20")	1
11	PT347-1386	281386, P0360-155-00500	AL257	Sensor cable - armored	1
	PT347-06000EM (not shown)			Sensor cable ZWW 600 (OEM) 265 mm (10.4")	1
	PT347-0450 (not shown)	P0497-002-00450	AL202	Sensor cable 450 mm (18")	1
	PT347-0015A (not shown) NEW	00B-15		Sensor cable 380 mm	1
	PT347-0181 (not shown)	46743300181	AL358	Sensor cable 305 mm - armored (12")	1

Sensor repairs available in select regions only.

Accessories

Centricut part number	Reference number	Alternate reference	Description	Pkg qty
PT311-0787 (not shown)	280787, P48413300001		Insulating ring	1
PT347-0920 (not shown) NEW	46713330920	AL221	Insulating ring	
PT347-0520 (not shown)	P0591-520-00001		Insulating plate	
PT347-0940 (not shown) NEW	46713330940	AL353	Torch inner top	
PT347-1240 (not shown) NEW	46713331240	AL351	Torch outer top	
PT347-0930 (not shown)	P0591-930-0001		Spatter protection plate	2
PT347-9006 (not shown) NEW	HNP-006		Connector cup - HNP	1

Optics

Centricut part number	Reference number	Type	Diameter	Focal length	Edge thickness
Lenses					
PT317-2550	562550	NEG-MEN	0.5"	1.658"	.074"
PT317-0002	406294	MEN	1.5"	5.0"	.290"
PT317-0001	452726	MEN	1.5"	7.5"	.125"
PT317-6326	206326	MEN	2.0"	5.0"	.378"
PT317-8936	468936/F	PLX	1.5"	2.5"	.085"
PT317-8275 NEW	628275	PLX	2.0"	10.0"	.310"
PT317-0537	960537	PLX	2.0"	10.0"	.380"
PT317-9527	779527	PLX	2.0"	10.0"	.500"

Centricut part number	Reference number	Material	Diameter	Edge thickness	Reflectivity
Phase shift mirrors					
PT317-6269		CU	1.969"	.394"	
PT317-5755		CU	2.36"	.394"	
PT317-4413		CU	2.36"	.591"	

Centricut part number	Reference number	Type	Material	Diameter	Edge thickness	S1
Zero phase shift mirrors and total reflectors						
PT317-6200	416200	MMR	CU	1.969"	.984"	WC
PT317-8962 NEW	698962	MMR	CU	1.969"	.984"	3.3MCC
PT317-7137	483962	MMR	CU	2.00"	.394"	5.7MCX
PT317-3098	690641	MMR	CU	2.00"	.394"	6.0MCC
PT317-2641 NEW	402641	MMR	CU	2.36"	.394"	6.6MCC
PT317-1610	816101	MMR	CU	2.36"	.984"	WC/FTGS
PT317-8825	408825	MMR	SI	2.0"	.200"	PO/FG
PT317-2137 NEW	532137	MMR	SI	2.0"	.200"	3MCC
PT317-9468 NEW	439468	PS	CU	1.969"	.394"	PO/SPT-90
PT317-7496	187496	PS	CU	1.969"	.984"	WC/FTGS
PT317-6392	886392	PS	CU	2.36"	.984"	WC/FTGS
PT317-8680	748680	PS	CU	3.0"	.500"	
PT317-4069	744069	PS	CU	3.0"	.591"	
PT317-2132	582132	PS	SI	2.0"	1.96"	
PT317-2353 NEW	592353	PS	SI	2.0"	.375"	
PT317-4562	264562	PS	SI	2.5"	.250"	
PT317-7197	917197	PS	SI	3.0"	.250"	
PT317-3811	213811	TRZ	CU	1.96"	.394"	CA-HOLE

Centricut part number	Reference number	Type	Material	Diameter	Edge thickness	S1
PT317-6908 NEW	436908	TRZ	CU	1.969"	.394"	45DEG
PT317-7599	837599	TRZ	CU	1.969"	.984"	WC
PT317-9495	119495	TRZ	CU	1.969"	.984"	WC/FTGS
PT317-8936 NEW	468936/F	TRZ	CU	2.0"	2.126"	SEG
PT317-6156	516156	TRZ	CU	2.362"	.394"	
PT317-2196 NEW	702196/F-CBM-75-LP-HOL	TRZ	CU	2.953"	.669"	MTD
PT317-6494	586494	TRZ	CU	3.0"	.591"	
PT317-1534	341534	TRZ	SI	2.0"	.200"	45DEG
PT317-0347	240347	TRZ	SI	2.5"	.250"	45DEG
PT317-6922	756922	TRZ	SI	3.0"	.250"	22.5DEG AOI

Centricut part number	Reference number	Material	Diameter	Edge thickness	S1/Reflectivity	S2
Output couplers						
PT317-6893	696893	ZNSE	1.0"	.200"	10MCC-65%	6MCX
PT317-9472	979472	ZNSE	1.0"	.236"	55%	
PT317-3834 NEW	383834	ZNSE	1.1"	.220"	20MCC-60%	5.5MCX
PT317-1224	541224	ZNSE	1.1"	.220"	20MCC-80%	
PT317-1765	554039	ZNSE	1.1"	.232"	15MCC-50%	7.5MCX
PT317-2548	932548	ZNSE	1.1"	.236"	65%	
PT317-5408	885408	ZNSE	1.1"	.236"	20MCC	
PT317-4883	164883	ZNSE	1.5"	.236"	15MCC-40%	
PT317-2030	652030	ZNSE	1.5"	.315"	15MCC-40%	
Rear mirrors						
PT317-4423	424423	GE	1.0"	.200"	99.5%	
PT317-3685	933685	GE	1.1"	.120"	15MCC	
PT317-9018	499018	GE	1.1"	.220"	30MCC-99.5%	23.62MCX
PT317-4144 NEW	424144	GE	1.5"	.236"	50MCC-99%	.75MCX
PT317-7692	907692	GE	1.5"	.315"	15MCC-99.5%	
PT317-9701	589701	ZNSE	1.1"	.220"	30MCC-99.5%	40MCX

Optics care

Centricut part number	Reference number	Description	Pkg qty
TR300-6452	N/A	Lens cleaning paper, Tiffen - 50 piece	1
AM313-SC50 NEW	SC50	Lens cleaning paper, Tresor - 50 piece	1
TR300-1115		Lens cleaning pre-cut cotton - 80 piece	1
TR300-SC20		Cotton swab - 20 piece	1
TR300-1010	AL1010	Dropper, lens cleaning fluid	1
TR300-255	AL255	Loupe, magnifying	1
TR300-271	AL271	Base, lens maintenance	1
TR300-7388	787388	Mirror polish (250 ml)	1
AM313-1260 NEW	351260-009	Lens Polarizing Filter - 1.5"	1
AM313-1280 NEW	351280-009	Lens Polarizing Filter - 2.0"	1



Consumables

	Centricut part number	Reference number	Alternate reference	Description	Pkg qty
1	PR331-4102	490.76.102	L70	Nozzle - 0.3 mm brass cylindrical	1
	PR331-4102X	490.76.102	L3070	Nozzle - 0.3 mm brass cylindrical (10 pack)	10
	PR331-0001B		L74	Nozzle - 1.0 mm brass cylindrical	1
	PR331-0001BX		L3074	Nozzle - 1.0 mm brass cylindrical (10 pack)	10
	PR331-0001		L418	Nozzle - 1.0 mm cylindrical	1
	PR331-0001X		L30418	Nozzle - 1.0 mm cylindrical (10 pack)	10
	PR331-0002		L416	Nozzle - 1.2 mm cylindrical	1
	PR331-0002X		L30416	Nozzle - 1.2 mm cylindrical (10 pack)	10
	PR331-3321B	485.73.321	L54	Nozzle - 1.5 mm brass cylindrical	1
	PR331-3321BX	485.73.321	L3054	Nozzle - 1.5 mm brass cylindrical (10 pack)	10
	PR331-3321C		L419	Nozzle - 1.5 mm cylindrical	1
	PR331-3321CX		L30419	Nozzle - 1.5 mm cylindrical (10 pack)	10
	PR331-0003		L417	Nozzle - 1.7 mm cylindrical	1
	PR331-0003X		L30417	Nozzle - 1.7 mm cylindrical (10 pack)	10
	PR331-3322B	485.73.322	L55	Nozzle - 2.0 mm brass cylindrical	1
	PR331-3322BX	485.73.322	L3055	Nozzle - 2.0 mm brass cylindrical (10 pack)	10
	PR331-322C		L420	Nozzle - 2.0 mm cylindrical	1
	PR331-322CX		L30420	Nozzle - 2.0 mm cylindrical (10 pack)	10
	PR331-3323B	485.73.323	L204	Nozzle - 2.5 mm brass cylindrical	1
	PR331-3323BX	485.73.323	L30204	Nozzle - 2.5 mm brass cylindrical (10 pack)	10
	PR331-3323C		L421	Nozzle - 2.5 mm cylindrical	1
	PR331-3323CX		L30421	Nozzle - 2.5 mm cylindrical (10 pack)	10
	PR331-3324B	485.73.324	L205	Nozzle - 3.0 mm brass cylindrical	1
	PR331-3324BX	485.73.324	L30205	Nozzle - 3.0 mm brass cylindrical (10 pack)	10
	PR331-3324		L422	Nozzle - 3.0 mm cylindrical	1
	PR331-3324X		L30422	Nozzle - 3.0 mm cylindrical (10 pack)	10
	PR331-0001CP		L418X	Nozzle - 1.0 mm CP	1
	PR331-0001CPX		L30418X	Nozzle - 1.0 mm CP (10 pack)	10
	PR331-0002CP		L416X	Nozzle - 1.2 mm CP	1
	PR331-0002CPX		L30416X	Nozzle - 1.2 mm CP (10 pack)	10
	PR331-0321CCP	485.73.421	L419X	Nozzle - 1.5 mm CP	1
	PR331-0321CCPX	485.73.421	L30419X	Nozzle - 1.5 mm CP (10 pack)	10
	PR331-0003CP		L417X	Nozzle - 1.7 mm CP	1
PR331-0003CPX		L30417X	Nozzle - 1.7 mm CP (10 pack)	10	
PR331-322CCP	485.73.422	L420X	Nozzle - 2.0 mm CP	1	
PR331-322CCPX	485.73.422	L30420X	Nozzle - 2.0 mm CP (10 pack)	10	
PR331-3323CCP	485.73.423	L421X	Nozzle - 2.5 mm CP	1	
PR331-3323CCPX	485.73.423	L30421X	Nozzle - 2.5 mm CP (10 pack)	10	
PR331-3324CP	485.73.424	L422X	Nozzle - 3.0 mm CP	1	
PR331-3324CPX	485.73.424	L30422X	Nozzle - 3.0 mm CP (10 pack)	10	
2	PR331-0302	490.1N.302	L1246	Nozzle - 2.5 mm brass short	1
	PR331-0302X	490.1N.302	L301246	Nozzle - 2.5 mm brass short (10 pack)	10



Consumables

	Centricut part number	Reference number	Alternate reference	Description	Pkg qty
1	PR393-0001		L631	Nozzle - 0.3 mm	1
	PR393-0001X		L30631	Nozzle - 0.3 mm (10 pack)	10
	PR393-0002		L632	Nozzle - 1.0 mm	1
	PR393-0002X		L30632	Nozzle - 1.0 mm (10 pack)	10
	PR393-0003		L637	Nozzle - 1.2 mm	1
	PR393-0003X		L30637	Nozzle - 1.2 mm (10 pack)	10
	PR393-0004		L633	Nozzle - 1.5 mm	1
	PR393-0004X		L30633	Nozzle - 1.5 mm (10 pack)	10
	PR398-0005		L638	Nozzle - 1.7 mm	1
	PR398-0005X		L30638	Nozzle - 1.7 mm (10 pack)	10
	PR393-0006		L634	Nozzle - 2.0 mm	1
	PR393-0006X		L30634	Nozzle - 2.0 mm (10 pack)	10
	PR393-0007		L635	Nozzle - 2.5 mm	1
	PR393-0007X		L30635	Nozzle - 2.5 mm (10 pack)	10
PR393-0008		L636	Nozzle - 3.0 mm	1	
PR393-0008X		L30636	Nozzle - 3.0 mm (10 pack)	10	
2	PR393-3455CP	485.73.455	L1231X	Nozzle - 0.3 mm CP	1
	PR393-3455CPX	485.73.455	L301231X	Nozzle - 0.3 mm CP (10 pack)	10
	PR393-3451CP	485.73.451	L1235X	Nozzle - 1.5 mm CP	1
	PR393-3451CPX	485.73.451	L301235X	Nozzle - 1.5 mm CP (10 pack)	10
	PR393-3452CP	485.73.452	L1236X	Nozzle - 2.0 mm CP	1
	PR393-3452CPX	485.73.452	L301236X	Nozzle - 2.0 mm CP (10 pack)	10
	PR393-3453CP	485.73.453	L1237X	Nozzle - 2.5 mm CP	1
	PR393-3453CPX	485.73.453	L301237X	Nozzle - 2.5 mm CP (10 pack)	10



Consumables

	Centricut part number	Reference number	Alternate reference	Description	Pkg qty
1	PR357-0001	490.76.103	L62	Nozzle - 0.3 mm conical brass	1
	PR357-0001X	490.76.103	L3062	Nozzle - 0.3 mm conical brass (10 pack)	10
	PR357-0002		L450	Nozzle - 1.0 mm conical	1
	PR357-0002X		L30450	Nozzle - 1.0 mm conical (10 pack)	10
	PR357-0003		L451	Nozzle - 1.2 mm conical	1
	PR357-0003X		L30451	Nozzle - 1.2 mm conical (10 pack)	10
	PR357-331B	485.73.331	L206	Nozzle - 1.5 mm conical brass	1
	PR357-331BX	485.73.331	L30206	Nozzle - 1.5 mm conical brass (10 pack)	10
	PR357-331C		L424	Nozzle - 1.5 mm conical	1
	PR357-331CX		L30424	Nozzle - 1.5 mm conical (10 pack)	10
	PR357-0004		L426	Nozzle - 1.7 mm conical	1
	PR357-0004X		L30426	Nozzle - 1.7 mm conical (10 pack)	10
	PR357-333B	485.73.333	L57	Nozzle - 2.0 mm conical brass	1
	PR357-333BX	485.73.333	L3057	Nozzle - 2.0 mm conical brass (10 pack)	10
	PR357-333C		L425	Nozzle - 2.0 mm conical	1
	PR357-333CX		L30425	Nozzle - 2.0 mm conical (10 pack)	10
	PR357-0005	485.73.333	L449	Nozzle - 2.5 mm conical brass	1
	PR357-0005X	485.73.333	L30449	Nozzle - 2.5 mm conical brass (10 pack)	10
	PR357-0006		L427	Nozzle - 2.5 mm conical	1
	PR357-0006X		L30427	Nozzle - 2.5 mm conical (10 pack)	10
	PR357-0007		L630	Nozzle - 3.0 mm conical	1
	PR357-0007X		L30630	Nozzle - 3.0 mm conical (10 pack)	10
	PR357-0002CP		L450X	Nozzle - 1.0 mm CP	1
	PR357-0002CPX		L30450X	Nozzle - 1.0 mm CP (10 pack)	10
	PR357-0003CP		L451X	Nozzle - 1.2 mm CP	1
	PR357-0003CPX		L30451X	Nozzle - 1.2 mm CP (10 pack)	10
	PR357-331CCP	485.73.431	L424X	Nozzle - 1.5 mm CP	1
	PR357-331CCPX	485.73.431	L30424X	Nozzle - 1.5 mm CP (10 pack)	10
	PR357-0004CP		L426X	Nozzle - 1.7 mm CP	1
	PR357-0004CPX		L30426X	Nozzle - 1.7 mm CP (10 pack)	10
	PR357-322CCP	485.73.433	L425X	Nozzle - 2.0 mm CP	1
	PR357-322CCPX	485.73.433	L30425X	Nozzle - 2.0 mm CP (10 pack)	10
	PR357-0006CP		L427X	Nozzle - 2.5 mm CP	1
	PR357-0006CPX		L30427X	Nozzle - 2.5 mm CP (10 pack)	10
PR357-0007CP	485.73.43x	L630X	Nozzle - 3.0 mm CP	1	
PR357-0007CPX	485.73.43x	L30630X	Nozzle - 3.0 mm CP (10 pack)	10	
2	PR395-0001	480.73.107	AL136	Insulating ring 5" (plastic)	1
	PR395-0002		AL163	Insulating ring 7.5" (plastic)	1

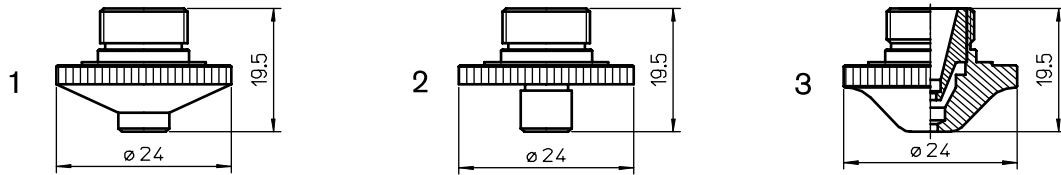

Consumables

	Centricut part number	Reference number	Alternate reference	Description	Pkg qty
1	PR351-1E109		L532	Nozzle - 0.8 mm	1
	PR351-1E110		L312	Nozzle - 1.0 mm	1
	PR351-1E108		L362	Nozzle - 1.2 mm	1
	PR351-1E111	LW6.1E.111	L207	Nozzle - 1.5 mm	1
	PR351-1E112	LW6.1E.112	L208	Nozzle - 2.0 mm	1
	PR351-1E113	LW6.1E.113	L209	Nozzle - 2.5 mm	1
	PR351-1E114	LW6.1E.114	L210	Nozzle - 3.0 mm	1
	PR351-1E110CP		L312X	Nozzle - 1.0 mm CP	1
	PR351-1E115CP		L362X	Nozzle - 1.2 mm CP	1
	PR351-1E111CP	LW6.1E.111	L207X	Nozzle - 1.5 mm CP	1
	PR351-1E112CP	LW6.1E.112	L208X	Nozzle - 2.0 mm CP	1
	PR351-1E113CP	LW6.1E.113	L209X	Nozzle - 2.5 mm CP	1
	PR351-1E114CP	LW6.1E.114	L210X	Nozzle - 3.0 mm CP	1
	2	PR366-1G600	LW6.1G.500, LW6.1G.600	L608	Nozzle - 1.5 mm
PR366-1G601		LW6.1G.501, LW6.1G.601	L609	Nozzle - 2.0 mm	1
PR366-1G602		LW6.1G.502, LW6.1G.602	L610	Nozzle - 2.5 mm	1
PR366-1G603		LW6.1G.503, LW6.1G.603	L611	Nozzle - 3.0 mm	1
PR366-1G601CP		LW6.1G.501, LW6.1G.601	L609X	Nozzle - 2.0 mm CP	1
PR366-1G602CP		LW6.1G.502, LW6.1G.602	L610X	Nozzle - 2.5 mm CP	1
PR366-1G603CP		LW6.1G.503, LW6.1G.603	L611X	Nozzle - 3.0 mm CP	1
3	PR362-0008CP	1059.70000.010	L905X	Nozzle - 0.8 mm double CP	1
	PR362-0003CP	1059.70000.003	L900X	Nozzle - 1.0 mm double CP	1
	PR362-0002CP	1059.70000.008	L907X	Nozzle - 1.25 mm double CP	1
	PR362-0005CP	1059.70000.004	L901X	Nozzle - 1.5 mm double CP	1
	PR362-0001CP	1059.70000.009	L906X	Nozzle - 1.75 mm double CP	1
	PR362-0004CP	1059.70000.005	L902X	Nozzle - 2.0 mm double CP	1
	PR362-0006CP	1059.70000.006	L903X	Nozzle - 2.5 mm double CP	1
	PR362-0007CP	1059.70000.007	L904X	Nozzle - 3.0 mm double CP	1

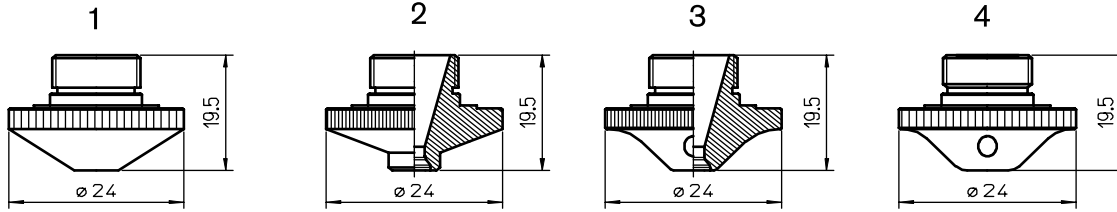
Consumables

	Centricut part number	Reference number	Alternate reference	Description	Pkg qty
1	PR422-0001	Centricut design	L862	Nozzle - 1.0 mm	1
	PR422-0002	Centricut design	L863	Nozzle - 1.5 mm	1
	PR422-0003	Centricut design	L864	Nozzle - 2.0 mm	1
	PR422-0004	Centricut design	L865	Nozzle - 2.5 mm	1
	PR422-0005	Centricut design	L866	Nozzle - 3.0 mm	1
2	PR422-0650CP	LW6.1G.650	L1165X	Nozzle - 3.0 mm CP	1
3	PR422-0608CP	LW6.1G.608	L1208X	Nozzle - 3.0 mm CP	1
	PR422-0609CP	LW6.1G.609	L1209X	Nozzle - 3.5 mm CP	1
4	PR394-604	LW6.1G.604	L1167X	Nozzle - 1.5 mm CP	1
	PR394-603		L1166X	Nozzle - 1.75 mm CP	1
	PR394-605	LW6.1G.605	L1168X	Nozzle - 2.0 mm CP	1
	PR394-606	LW6.1G.606	L1169X	Nozzle - 2.5 mm CP	1
	PR394-607	LW6.1G.607	L1170X	Nozzle - 3.0 mm CP	1

Sensor cables

	Centricut part number	Reference number	Alternate reference	Description	Pkg qty
1	PR361-3150 (not shown) NEW	820.63.150		Sensor cable - 150 mm	1

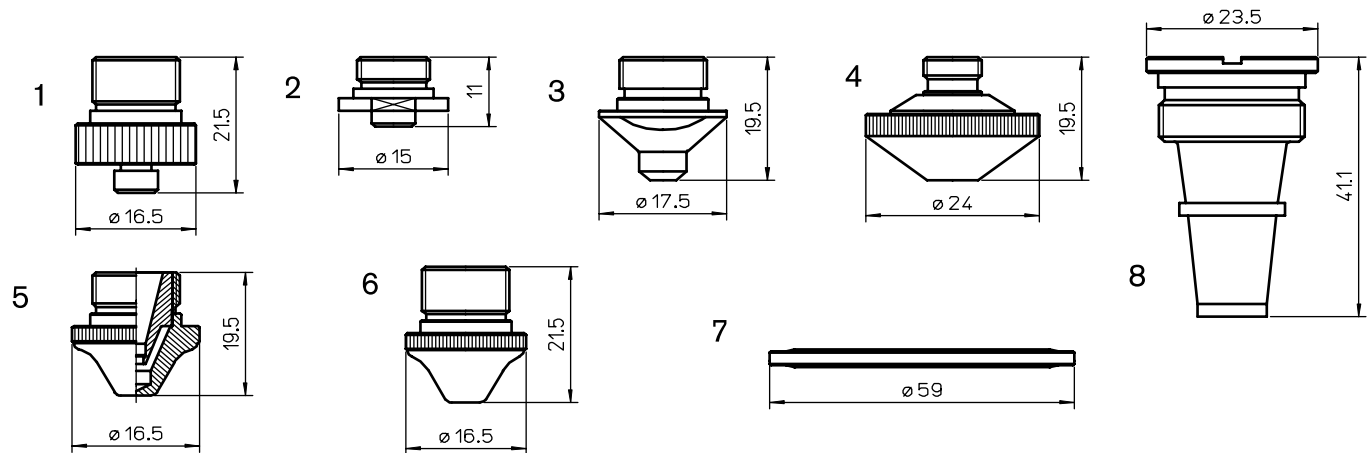

Consumables

	Centricut part number	Reference number	Alternate reference	Description	Pkg qty
1	PR396-508	787.04.508	L1175	Nozzle - 1.5 mm	1
	PR396-509	787.04.509	L1176	Nozzle - 2.0 mm	1
	PR396-510	787.04.510	L1177	Nozzle - 2.5 mm	1
	PR396-511	787.04.511	L1178	Nozzle - 3.0 mm	1
2	PR397-0012		L534	Nozzle - 1.2 mm	1
	PR397-0001		L535	Nozzle - 1.5 mm	1
	PR397-0002		L536	Nozzle - 2.0 mm	1
	PR397-0003		L537	Nozzle - 2.5 mm	1
3	PR398-498	750.42.559	L922	Nozzle - 0.3 mm	1
	PR398-0001		L891	Nozzle - 1.0 mm	1
	PR398-550	750.42.550	L892	Nozzle - 1.5 mm	1
	PR398-551	750.42.551	L893	Nozzle - 2.0 mm	1
	PR398-552	750.42.552	L894	Nozzle - 2.5 mm	1
	PR398-0004	750.42.553	L895	Nozzle - 3.0 mm	1
	PR398-0001CP		L891X	Nozzle - 1.0 mm CP	1
	PR398-0006	750.42.550	L892X	Nozzle - 1.5 mm CP	1
	PR398-0002CP	750.42.551	L893X	Nozzle - 2.0 mm CP	1
	PR398-0003CP	750.42.552	L894X	Nozzle - 2.5 mm CP	1
	PR398-0004CP	750.42.553	L895X	Nozzle - 3.0 mm CP	1
	4	PR399-0001		L875	Nozzle - 1.0 mm
PR399-0002			L876	Nozzle - 1.5 mm	1
PR399-0003		LW3.1E.102	L877	Nozzle - 2.0 mm	1
PR399-0004		LW3.1E.103	L878	Nozzle - 2.5 mm	1
PR399-0005		LW3.1E.104	L879	Nozzle - 3.0 mm	1
5	PR421-111CP	520.17.111	L1239X	Nozzle - 1.5 mm double CP	1
	PR421-114CP	520.17.114	L1240X	Nozzle - 2.0 mm double CP	1
	PR421-560CP	750.43.560	L1241X	Nozzle - 2.5 mm double CP	1
	PR421-561CP	750.43.561	L1242X	Nozzle - 3.0 mm double CP	1
	PR421-562CP	750.43.562	L1243X	Nozzle - 3.5 mm double CP	1
6	PR409-4515	787.04.515	L1211X	Nozzle - 1.25 mm CP	1
	PR409-4512	787.04.512	L1212X	Nozzle - 1.5 mm CP	1
	PR409-4516	787.04.516	L1217X	Nozzle - 1.75 mm CP	1
	PR409-4513	787.04.513	L1213X	Nozzle - 2.0 mm CP	1
	PR409-4514	787.04.514	L1214X	Nozzle - 2.5 mm CP	1
7	PR421-720	1058.36520.720	AL259	Lens gasket	1
8	PR422-1198		L1198	Nozzle (welding)	1

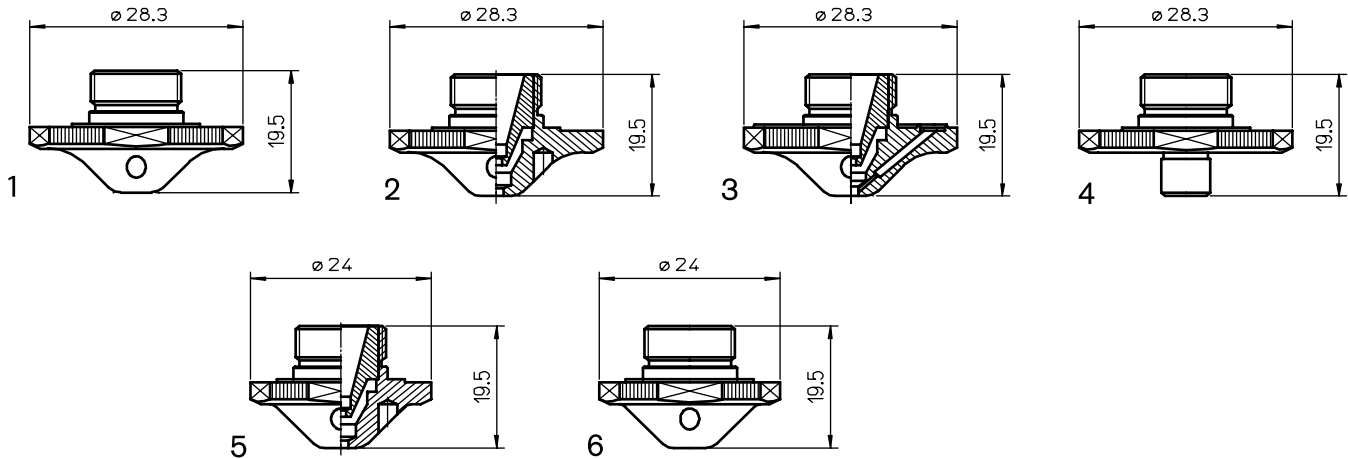

Consumables

	Centricut part number	Reference number	Alternate reference	Description	Pkg qty
1	PR422-0660 NEW	LW6.1G.660	L1428X	Nozzle pentagonal 0.8 mm CP	1
	PR422-0661 NEW	LW6.1G.661	L1429X	Nozzle pentagonal 1.0 mm CP	1
	PR422-0662 NEW	LW6.1G.662	L1430X	Nozzle pentagonal 1.25 mm CP	1
	PR422-0663 NEW	LW6.1G.663	L1431X	Nozzle pentagonal 1.5 mm CP	1
	PR422-0664 NEW	LW6.1G.664	L1432X	Nozzle pentagonal 1.75 mm CP	1
	PR422-0665 NEW	LW6.1G.665	L1433X	Nozzle pentagonal 2.0 mm CP	1
	PR422-0666 NEW	LW6.1G.666	L1434X	Nozzle pentagonal 2.25 mm CP	1
	PR422-0667 NEW	LW6.1G.667	L1435X	Nozzle pentagonal 2.5 mm CP	1
	PR422-0668 NEW	LW6.1G.668	L1436X	Nozzle pentagonal 2.75 mm CP	1
	PR422-0669 NEW	LW6.1G.669	L1437X	Nozzle pentagonal 3.0 mm CP	1
	PR422-0670 NEW	LW6.1G.670	L1438X	Nozzle pentagonal 3.5 mm CP	1
2	PR422-0680 NEW	LW6.1G.680	L1440X	Double nozzle pentagonal 0.8 mm CP	1
	PR422-0681 NEW	LW6.1G.681	L1441X	Double nozzle pentagonal 1.0 mm CP	1
	PR422-0682 NEW	LW6.1G.682	L1442X	Double nozzle pentagonal 1.25 mm CP	1
	PR422-0683 NEW	LW6.1G.683	L1443X	Double nozzle pentagonal 1.5 mm CP	1
	PR422-0684 NEW	LW6.1G.684	L1444X	Double nozzle pentagonal 1.75 mm CP	1
	PR422-0685 NEW	LW6.1G.685	L1445X	Double nozzle pentagonal 2.0 mm CP	1
	PR422-0686 NEW	LW6.1G.686	L1446X	Double nozzle pentagonal 2.25 mm CP	1
	PR422-0687 NEW	LW6.1G.687	L1447X	Double nozzle pentagonal 2.5 mm CP	1
	PR422-0688 NEW	LW6.1G.688	L1448X	Double nozzle pentagonal 2.75 mm CP	1
	PR422-0689 NEW	LW6.1G.689	L1449X	Double nozzle pentagonal 3.0 mm CP	1
	PR422-0800 NEW	LW6.1G.800	L1465	Double nozzle brilliant 3.0 mm	1
	PR422-0801 NEW	LW6.1G.801	L1466	Double nozzle brilliant 3.5 mm	1
	PR422-0802 NEW	LW6.1G.802	L1467	Double nozzle brilliant 4.0 mm	1
	PR422-0803 NEW	LW6.1G.803	L1468	Double nozzle brilliant 5.0 mm	1
PR422-0804 NEW	LW6.1G.804	L1469	Double nozzle brilliant 7.0 mm	1	
3	PR422-0627 NEW	LW6.1G.627	L1453X	Triple nozzle pentagonal 1.25 mm CP	1
	PR422-0620 NEW	LW6.1G.620	L1454X	Triple nozzle pentagonal 1.5 mm CP	1
	PR422-0621 NEW	LW6.1G.621	L1455X	Triple nozzle pentagonal 1.75 mm CP	1
	PR422-0622 NEW	LW6.1G.622	L1456X	Triple nozzle pentagonal 2.0 mm CP	1
	PR422-0623 NEW	LW6.1G.623	L1457X	Triple nozzle pentagonal 2.25 mm CP	1
	PR422-0624 NEW	LW6.1G.624	L1458X	Triple nozzle pentagonal 2.5 mm CP	1
	PR422-0625 NEW	LW6.1G.625	L1459X	Triple nozzle pentagonal 2.75 mm CP	1
PR422-0626 NEW	LW6.1G.626	L1460X	Triple nozzle pentagonal 3.0 mm CP	1	
4	PR422-0700 NEW	LW6.1G.700	L1478X	Nozzle pentagonal 2.0 mm CYL	1
5	PR422-0643 NEW	LW6.1G.643	L1540X	Double nozzle pentagonal 1.5 mm CP	1
	PR422-0645 NEW	LW6.1G.645	L1541X	Double nozzle pentagonal 2.0 mm CP	1
	PR422-0647 NEW	LW6.1G.647	L1542X	Double nozzle pentagonal 2.5 mm CP	1
6	PR422-0633 NEW	LW6.1G.633	L1533X	Nozzle pentagonal 1.5 mm CP	1
	PR422-0635 NEW	LW6.1G.635	L1534X	Nozzle pentagonal 2.0 mm CP	1
	PR422-0635 NEW	LW6.1G.637	L1535X	Nozzle pentagonal 2.5 mm CP	1

Centricut is a registered trademark of Hypertherm Inc. and may be registered in the United States and/or other countries. All other trademarks are the properties of their respective owners. Centricut is in no way affiliated with Prima Industrie.

Optics

Centricut part number	Reference number	Type	Diameter	Focal length	Edge thickness
Lenses					
PR361-9002	834-319-002	PLX	1.5"	5.0"	.236"
PR361-0773	970773	PLX	1.5"	5.0"	.275"
PR361-9011	834-319-011	PLX	1.5"	5.0"	.300"
PR361-8988	NEW LH968988PVL	PLX	1.5"	5.0"	FS (1070nm)
PR361-0003	834-319-003	PLX	1.5"	7.5"	.236"
PR361-9012	834-319-012	PLX	1.5"	7.5"	.300"
PR361-0004	120216	MEN	1.5"	5.0"	.354"
PR361-0005	570721	MEN	1.5"	7.5"	.354"
PR361-0001	741363	PLX	2.0"	5.0"	.380"
PR361-0002	232771	PLX	2.0"	7.5"	.380"

Centricut part number	Reference number	Type	Material	Diameter	Edge thickness	S1
Phase shift mirrors						
PR361-4054		PS	CU	2.75"	.984"	w/FTGS
PR361-6958	586958	PS	CU	2.36"	.787"	
PR361-0946	200946	PS	CU	2.5"	.394"	
Zero phase shift mirrors and total reflectors						
PR361-0029	1057.81000.029	MMR	CU	1.969"	.984"	
PR361-0031	1057.81000.031	MMR	CU	1.969"	.984"	1.44MCC
PR361-0201	NEW 199851	MMR	CU	2.362"	3.15"	.315"
PR361-1595	861595/F	MMR	CU	2.75"	.984"	w/FTGS
PR361-4831	134831	MMR	SI	1.5"	.250"	
PR361-6671	656671	MMR	SI	1.5"	.250"	
PR361-3010	NEW 403010	REFL	CU	1.69"	2.36"	SNEG/UC
PR361-4386	NEW 504386	TRZ	SI	1.5"	.250"	20MCC ES
PR361-4700	169246/F	TRZ	CU	1.5"	.787"	
PR361-1884	761884	TRZ	CU	1.69"	.236"	
PR361-0030	1057.81000.030	TRZ	CU	1.969"	.984"	0.9MCX
PR361-6359	296359	TRZ	CU	2.36"	.787"	
PR361-1128	NEW 52031128, 689384	TRZ	CU	2.36"	1.692"	.2362"
PR361-1819	NEW 181819	TRZ	CU	2.36"	3.15"	.315 WC
PR361-9520	929520	TRZ	CU	2.5"	.394"	

Centricut part number	Reference number	Material	Diameter	Edge thickness	S1/Reflectivity	S2
Output couplers						
PR361-5256	915256	ZNSE	1.0"	.236"	20MCC-99.5%	
PR361-2168	512168	ZNSE	1.0"	.236"	20MCC-50%	20MCX
PR361-8038	258038	ZNSE	1.0"	.236"	20MCC-50%	9MCX
PR361-6411	0546-411-00	ZNSE	1.1"	.236"	15MCC-50%	
PR361-8586	538586	ZNSE	1.1"	.236"	15MCC-40%	7.5MCX
PR361-6260	646260	ZNSE	1.5"	.315"	35MCC-70%	15MCX
Rear mirrors						
PR361-6412	0546-412-00	GE	1.1"	.236"	15MCC-99.7%	

Optics care

Centricut part number	Reference number	Description	Pkg qty
TR300-6452	N/A	Lens cleaning paper, Tiffen - 50 piece	1
AM313-SC50	NEW SC50	Lens cleaning paper, Tresor - 50 piece	1
TR300-1115		Lens cleaning pre-cut cotton - 80 piece	1
TR300-SC20		Cotton swab - 20 piece	1
TR300-1010	AL1010	Dropper, lens cleaning fluid	1
TR300-255	AL255	Loupe, magnifying	1
TR300-271	AL271	Base, lens maintenance	1
TR300-7388	787388	Mirror polish (250 ml)	1
AM313-1260	NEW 351260-009	Lens Polarizing Filter - 1.5"	1
AM313-1280	NEW 351280-009	Lens Polarizing Filter - 2.0"	1

Centricut is a registered trademark of Hypertherm Inc. and may be registered in the United States and/or other countries. All other trademarks are the properties of their respective owners. Centricut is in no way affiliated with Prima Industrie.

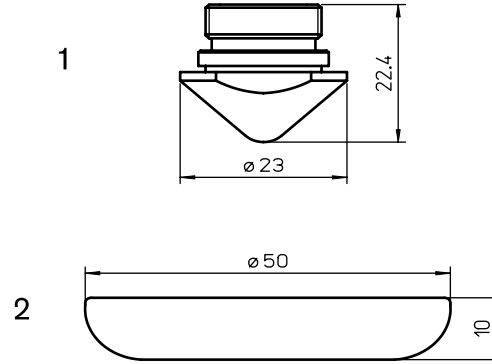

Consumables

	Centricut part number	Reference number	Alternate reference	Description	Pkg qty
1	RA403-0010		L31	Nozzle - 1.0 mm	1
	BE370-0006		L52	Nozzle - 1.1 mm	1
	BE371-0006		L53	Nozzle - 1.5 mm	1
2	RA403-0002		AL9	Stylus foot - steel	1
	RA403-0003		AL51	Stylus foot - PTFE*	1

*PolyTetraFluoroEthylene is a fluorocarbon-based polymer and is commonly abbreviated PTFE. The Teflon® brand of PTFE is manufactured only by DuPont and is not sold by Hypertherm. Hypertherm purchases other brands of PTFE from various high quality manufacturers.

Optics care

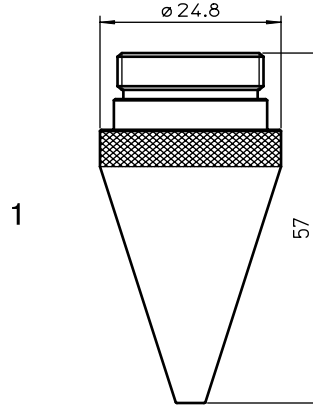
Centricut part number	Reference number	Description	Pkg qty
TR300-6452	N/A	Lens cleaning paper, Tiffen - 50 piece	1
AM313-SC50 NEW	SC50	Lens cleaning paper, Tresor - 50 piece	1
TR300-1115		Lens cleaning pre-cut cotton - 80 piece	1
TR300-SC20		Cotton swab - 20 piece	1
TR300-1010	AL1010	Dropper, lens cleaning fluid	1
TR300-255	AL255	Loupe, magnifying	1
TR300-271	AL271	Base, lens maintenance	1
TR300-7388	787388	Mirror polish (250 ml)	1
AM313-1260 NEW	351260-009	Lens Polarizing Filter - 1.5"	1
AM313-1280 NEW	351280-009	Lens Polarizing Filter - 2.0"	1



Consumables

	Centricut part number	Reference number	Alternate reference	Description	Pkg qty
1	R0404-0125		L690	Nozzle - 1.25 mm	1
	R0404-0015		L177	Nozzle - 1.5 mm	1
	R0404-0020		L202	Nozzle - 2.0 mm	1

Optics care

Centricut part number	Reference number	Description	Pkg qty
TR300-6452	N/A	Lens cleaning paper, Tiffen - 50 piece	1
AM313-SC50 NEW	SC50	Lens cleaning paper, Tresor - 50 piece	1
TR300-1115		Lens cleaning pre-cut cotton - 80 piece	1
TR300-SC20		Cotton swab - 20 piece	1
TR300-1010	AL1010	Dropper, lens cleaning fluid	1
TR300-255	AL255	Loupe, magnifying	1
TR300-271	AL271	Base, lens maintenance	1
TR300-7388	787388	Mirror polish (250 ml)	1
AM313-1260 NEW	351260-009	Lens Polarizing Filter - 1.5"	1
AM313-1280 NEW	351280-009	Lens Polarizing Filter - 2.0"	1

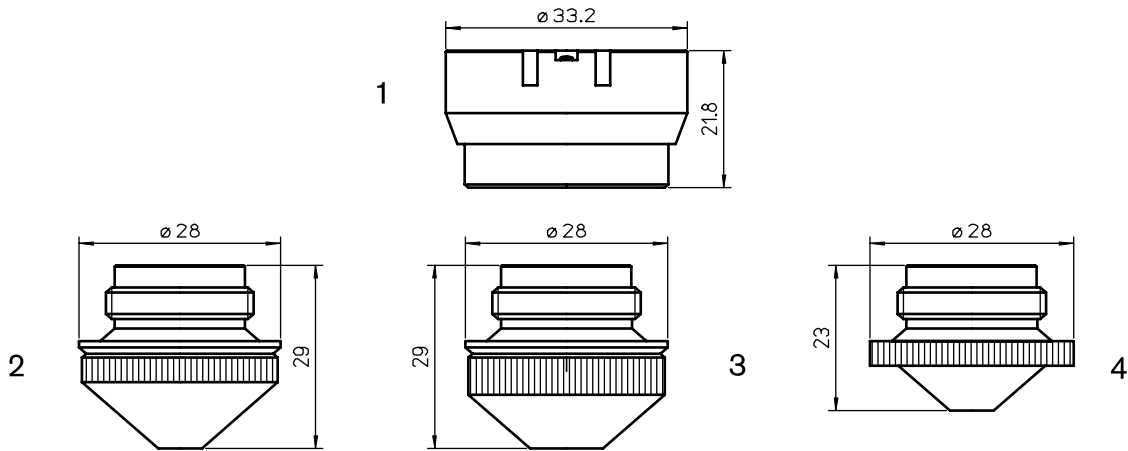
5"DL PRECITEC® SENSOR SYSTEM



Consumables

	Centricut part number	Reference number	Alternate reference	Description	Pkg qty
1	PT311-1146	281146, P0380-211-00001	AL130/S	Nozzle holder - IT M1.5" DZ - aluminum	1
	PT311-11460EM	281146, P0380-211-00001	AL130	Nozzle holder - IT M1.5" DZ - aluminum	1
2	SA365-00A4	141300A4	L374	Nozzle - 0.75 mm	1
	SA365-01A4	146331A4	L375	Nozzle - 1.0 mm	1
	SA365-30A4	146330A4	L376	Nozzle - 1.25 mm	1
	SA365-97A4	146329A4, 142321A4	L377	Nozzle - 1.5 mm	1
	SA365-98A4	146328A4	L378	Nozzle - 1.75 mm	1
	SA365-99A4	146327A4, 142322A4	L379	Nozzle - 2.0 mm	1
	SA365-25A4	146326A4	L381	Nozzle - 2.25 mm	1
	SA365-26A4	146325A4, 142324A4	L380	Nozzle - 2.5 mm	1
	SA365-24A4	146324A4	L888	Nozzle - 2.75 mm	1
	SA365-23A4	146323A4	L889	Nozzle - 3.0 mm	1
	SA365-00A4CP	141300A4	L374X	Nozzle - 0.75 mm CP	1
	SA365-01A4CP	146331A4	L375X	Nozzle - 1.0 mm CP	1
	SA365-30A4CP	146330A4	L376X	Nozzle - 1.25 mm CP	1
	SA365-97A4CP	146329A4	L377X	Nozzle - 1.5 mm CP	1
	SA365-98A4CP	146328A4	L378X	Nozzle - 1.75 mm CP	1
	SA365-99A4CP	146327A4	L379X	Nozzle - 2.0 mm CP	1
	SA365-26A4CP	146326A4	L381X	Nozzle - 2.25 mm CP	1
	SA365-25A4CP	146325A4	L380X	Nozzle - 2.5 mm CP	1
	SA365-24A4CP	146324A4	L888X	Nozzle - 2.75 mm CP	1
	SA365-23A4CP	146323A4	L889X	Nozzle - 3.0 mm CP	1
3	SA365-0001		L570	Nozzle - 1.2 mm	1
4	SA365-51A4	144151A4	L1000	Nozzle - 2.0 mm short	1
	SA365-125A4	144125A4	L1001	Nozzle - 2.25 mm short	1
	SA365-52A4	144152A4	L1002	Nozzle - 2.5 mm short	1
	SA365-57A4	144057A4	L1005	Nozzle - 2.75 mm short	1
	SA365-53A4	144153A4	L1003	Nozzle - 3.0 mm short	1

5"DL PRECITEC® SENSOR SYSTEM

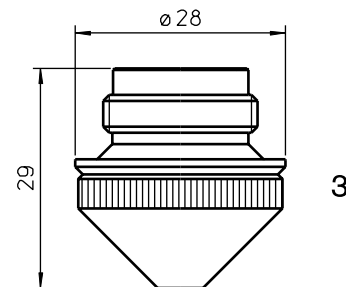
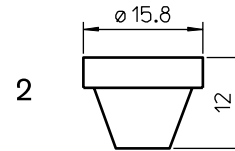
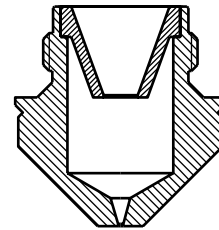
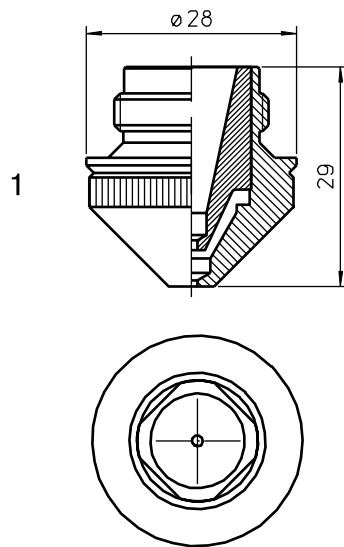

Consumables

	Centricut part number	Reference number	Alternate reference	Description	Pkg qty
1	SA423-0001	Centricut design	L988X	Nozzle - 1.0 mm double CP	1
	SA423-0002	Centricut design	L989X	Nozzle - 1.25 mm double CP	1
	SA423-0003	Centricut design	L990X	Nozzle - 1.5 mm double CP	1
	SA423-0004	Centricut design	L991X	Nozzle - 1.75 mm double CP	1
	SA423-0005	Centricut design	L992X	Nozzle - 2.0 mm double CP	1
	SA423-0006	Centricut design	L993X	Nozzle - 2.25 mm double CP	1
	SA423-0007	Centricut design	L994X	Nozzle - 2.5 mm double CP	1
	SA423-0008	Centricut design	L995X	Nozzle - 2.7 mm double CP	1
	SA423-0009	Centricut design	L996X	Nozzle - 3.0 mm double CP	1
2	LV418-0001	Centricut design	L157	Nozzle, inner	1
3	SA423-0010	Centricut design	L772	Nozzle - 0.75 mm outer	1
	SA423-0011	Centricut design	L773	Nozzle - 1.0 mm outer	1
	SA423-0012	Centricut design	L774	Nozzle - 1.25 mm outer	1
	SA423-0013	Centricut design	L775	Nozzle - 1.5 mm outer	1
	SA423-0014	Centricut design	L776	Nozzle - 1.75 mm outer	1
	SA423-0015	Centricut design	L777	Nozzle - 2.0 mm outer	1
	SA423-0016	Centricut design	L778	Nozzle - 2.5 mm outer	1

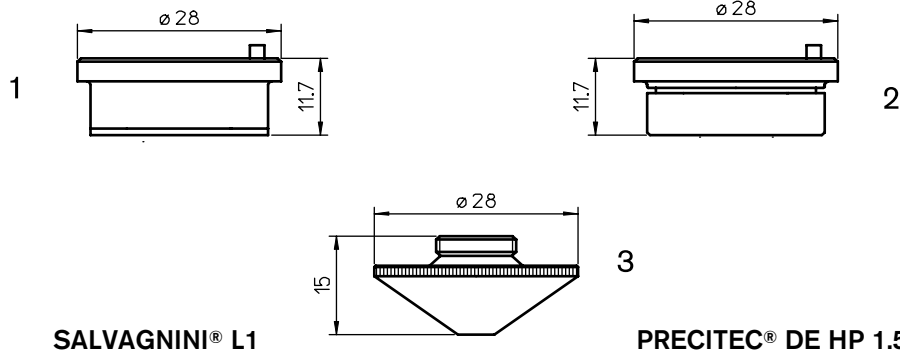

Consumables

	Centricut part number	Reference number	Alternate reference	Description	Pkg qty
1	PT348-1330	281330, P0571-260-00001	AL131	Nozzle holder - ceramic	1
	PT348-13300EM	281330, P0571-260-00001	AL23	Nozzle holder - ceramic (OEM)	1
	PT348-1051	P0571-1051-00001	AL355	Nozzle holder - OEM KT B2"	1
2	PT348-1330C NEW	P0571-260-00001	AL331	Nozzle holder - ceramic	1
3	PT345-0008		L935	Nozzle - 0.8 mm HD	1
	PT345-1548	281548, P0591-571-00010	L234	Nozzle - 1.0 mm HD	1
	PT345-1549	281549, P0591-572-00012	L235	Nozzle - 1.2 mm HD	1
	PT345-1463	281463, P0591-573-00015	L236	Nozzle - 1.5 mm HD	1
	PT345-0001	P0591-574-00018	L237	Nozzle - 1.8 mm HD	1
	PT345-1550	281550, P0591-575-00020	L238	Nozzle - 2.0 mm HD	1
	PT345-0003		L239	Nozzle - 2.3 mm HD	1
	PT345-1551	281551, P0591-576-00025	L240	Nozzle - 2.5 mm HD	1
	PT345-1552		L936	Nozzle - 2.75 mm HD	1
	PT345-0002		L241	Nozzle - 3.0 mm HD	1
	PT345-0005		L826	Nozzle - 3.2 mm HD	1
	PT345-0006		L827	Nozzle - 3.5 mm HD	1
	PT345-0004		L828	Nozzle - 4.0 mm HD	1
	PT345-0007		L829	Nozzle - 4.5 mm HD	1
	PT345-1548CP	281548, P0591-571-00010	L234X	Nozzle - 1.0 mm HD CP	1
	PT345-1549CP	281549, P0591-572-00012	L235X	Nozzle - 1.2 mm HD CP	1
	PT345-1463CP	281463, P0591-573-00015	L236X	Nozzle - 1.5 mm HD CP	1
	PT345-0001CP		L237X	Nozzle - 1.8 mm HD CP	1
	PT345-1550CP	281550, P0591-575-00020	L238X	Nozzle - 2.0 mm HD CP	1
	PT345-0003CP		L239X	Nozzle - 2.3 mm HD CP	1
	PT345-1551CP	281551, P0591-576-00025	L240X	Nozzle - 2.5 mm HD CP	1
	PT345-1552CP		L936X	Nozzle - 2.75 mm HD CP	1
	PT345-0002CP		L241X	Nozzle - 3.0 mm HD CP	1
	PT345-0005CP		L826X	Nozzle - 3.2 mm HD CP	1
	PT345-0006CP		L827X	Nozzle - 3.5 mm HD CP	1
	PT345-0004CP		L828X	Nozzle - 4.0 mm HD CP	1
	PT345-0007CP		L829X	Nozzle - 4.5 mm HD CP	1

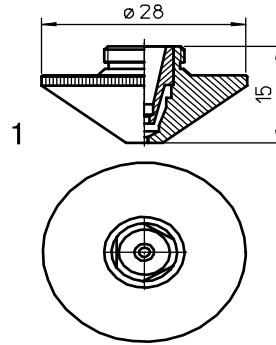

SALVAGNINI® L1

PRECITEC® DE HP 1.5"

Consumables

	Centricut part number	Reference number	Alternate reference	Description	Pkg qty
1	PT358-0669	Centricut design	L669	Nozzle - 0.8 mm double	1
	PT358-0010	Centricut design	L660	Nozzle - 1.0 mm double	1
	PT358-0125	Centricut design	L661	Nozzle - 1.2 mm double	1
	PT358-0015	Centricut design	L662	Nozzle - 1.5 mm double	1
	PT358-0018	Centricut design	L663	Nozzle - 1.8 mm double	1
	PT358-0020	Centricut design	L664	Nozzle - 2.0 mm double	1
	PT358-0023	Centricut design	L665	Nozzle - 2.3 mm double	1
	PT358-0007	Centricut design	L666	Nozzle - 2.5 mm double	1
	PT358-0030	Centricut design	L667	Nozzle - 3.0 mm double	1
	PT358-0035	Centricut design	L668	Nozzle - 3.5 mm double	1
	PT358-0010CP	Centricut design	L660X	Nozzle - 1.0 mm double CP	1
	PT358-0125CP	Centricut design	L661X	Nozzle - 1.2 mm double CP	1
	PT358-0015CP	Centricut design	L662X	Nozzle - 1.5 mm double CP	1
	PT358-0018CP	Centricut design	L663X	Nozzle - 1.8 mm double CP	1
	PT358-0020CP	Centricut design	L664X	Nozzle - 2.0 mm double CP	1
	PT358-0023CP	Centricut design	L665X	Nozzle - 2.3 mm double CP	1
	PT358-0025CP	Centricut design	L666X	Nozzle - 2.5 mm double CP	1
	PT358-0030CP	Centricut design	L667X	Nozzle - 3.0 mm double CP	1
	PT358-0035CP	Centricut design	L668X	Nozzle - 3.5 mm double CP	1

Optics care

Centricut part number	Reference number	Description	Pkg qty
TR300-6452	N/A	Lens cleaning paper, Tiffen - 50 piece	1
AM313-SC50 NEW	SC50	Lens cleaning paper, Tresor - 50 piece	1
TR300-1115		Lens cleaning pre-cut cotton - 80 piece	1
TR300-SC20		Cotton swab - 20 piece	1
TR300-1010	AL1010	Dropper, lens cleaning fluid	1
TR300-255	AL255	Loupe, magnifying	1
TR300-271	AL271	Base, lens maintenance	1
TR300-7388	787388	Mirror polish (250 ml)	1
AM313-1260 NEW	351260-009	Lens Polarizing Filter - 1.5"	1
AM313-1280 NEW	351280-009	Lens Polarizing Filter - 2.0"	1

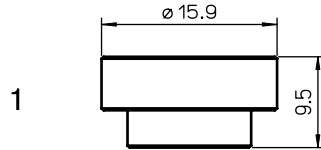

Consumables

	Centricut part number	Reference number	Alternate reference	Description	Pkg qty
1	ST337-6054-100	106054-100	L3	Nozzle - 1.0 mm	1
	ST337-6054-150	106054-150	L64	Nozzle - 1.5 mm	1
	ST337-6054-200	106054-200	L65	Nozzle - 2.0 mm	1
	ST363-1019 (not shown)	1001019-000	L712	Nozzle - 1.0 mm	1
	ST363-1020 (not shown)	1001010-000	L225	Nozzle - 2.0 mm	1

Optics care

Centricut part number	Reference number	Description	Pkg qty
TR300-6452	N/A	Lens cleaning paper, Tiffen - 50 piece	1
AM313-SC50 NEW	SC50	Lens cleaning paper, Tresor - 50 piece	1
TR300-1115		Lens cleaning pre-cut cotton - 80 piece	1
TR300-SC20		Cotton swab - 20 piece	1
TR300-1010	AL1010	Dropper, lens cleaning fluid	1
TR300-255	AL255	Loupe, magnifying	1
TR300-271	AL271	Base, lens maintenance	1
TR300-7388	787388	Mirror polish (250 ml)	1
AM313-1260 NEW	351260-009	Lens Polarizing Filter - 1.5"	1
AM313-1280 NEW	351280-009	Lens Polarizing Filter - 2.0"	1

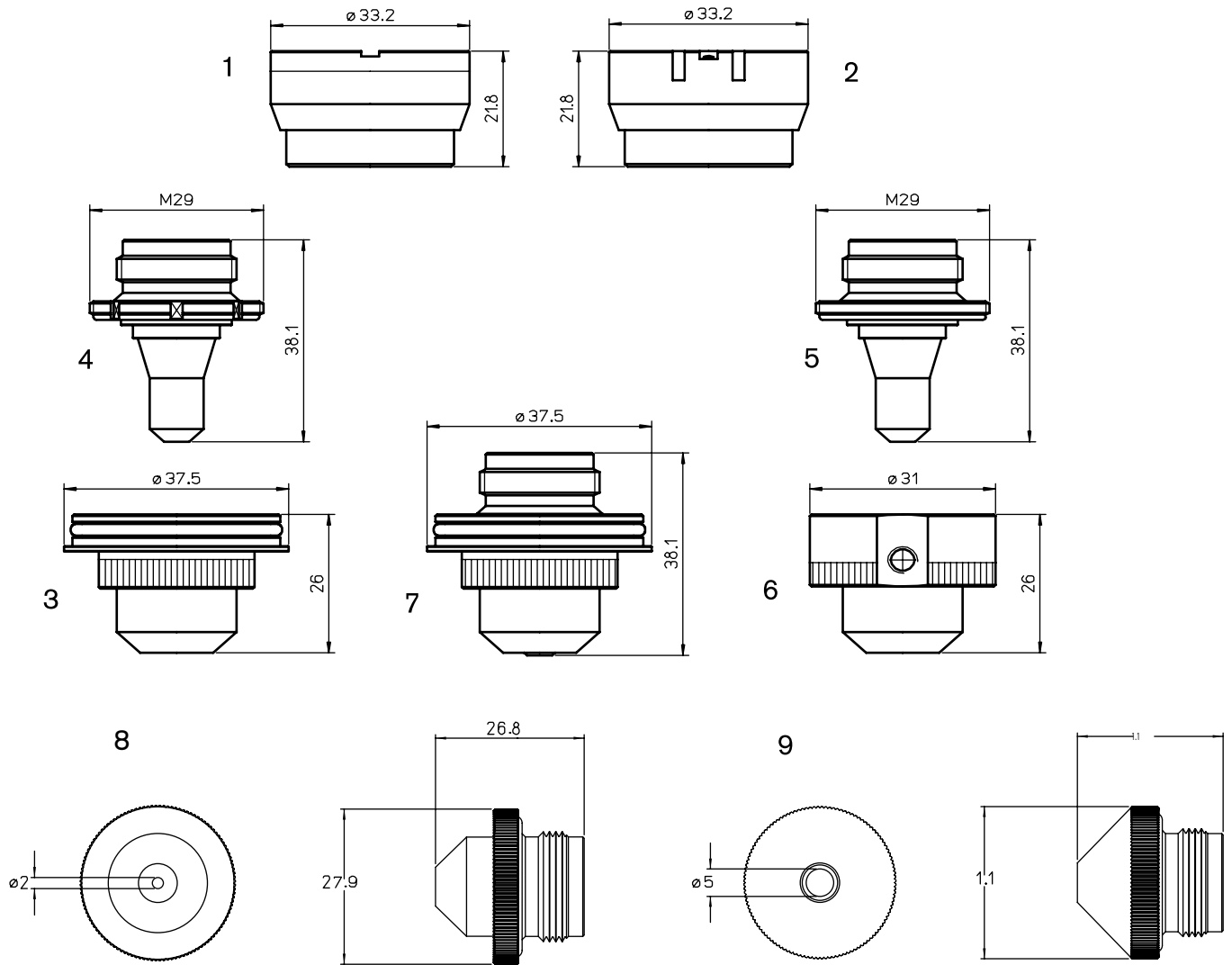

Consumables

	Centricut part number	Reference number	Alternate reference	Description	Pkg qty
1	PT311-0565	280565, P0497-605-00001, 29100106	AL40	Nozzle holder - KTM 1.5" DXN - ceramic	1
2	PT311-1146OEM	281146, P0380-211-00001, 29100033	AL130	Nozzle holder - ITM 1.5" DZ - aluminum - OEM	1
	PT311-1146	281146, P0380-211-00001, 29100033	AL130/S	Nozzle holder - ITM 1.5" DZ - aluminum	1
3	TK381-C20E-0	C20E-2	AL283	Nozzle, outer	1
4	TK381-C20E-1	C20E-1	L1200	Nozzle - 2.0 mm	1
	TK381-C17E-1	C17E-1	L1201	Nozzle - 1.7 mm	1
5	TK364-C15D-1	C15D-1	L1516	Nozzle - 1.5 mm	1
	TK364-C20D-1	C20D-1	L1517	Nozzle - 2.0 mm	1
	TK364-C22D-1	C22D-1	L1518	Nozzle - 2.2 mm	1
6	TK364-C22D-0	C22D-2	AL381	Nozzle, outer	1
7	TK381-C20E-2	C20E	L1205	Nozzle assembly	1
	TK381-C17E-2 NEW		L1204	Nozzle assembly C17E	1
8	TK354-S17B NEW	S17B		Nozzle - 1.7 mm	1
	TK354-S20B NEW	S20B		Nozzle - 2.0 mm	1
	TK354-S30B NEW	S30B		Nozzle - 3.0 mm	1
9	TK354-D40 NEW	D40		Nozzle - 4.0 mm	1
	TK354-D50 NEW	D50		Nozzle - 5.0 mm	1

Optics

Centricut part number	Reference number	Type	Diameter	Focal length	Edge thickness
Lenses					
TK374-2235	NEW 312235	PLX	1.5"	12.5"	.300"
TK374-3478	541344, 263478	PLX	2.0"	8.75"	.310"
TK374-7338	197338	PLX	2.0"	11.25"	.310"
TK374-3827	243827	PLX	2.5"	8.75"	.310"
TK374-6670	236670	PLX	2.5"	10.0"	.390"
TK374-8593	NEW 828593	PLX	2.5"	12.5"	.390"

Centricut part number	Reference number	Type	Material	Diameter	Edge thickness	S1
Zero phase shift mirrors and total reflectors						
TK374-9822	659822	MMR	CU	2.756"	.984"	
TK374-1165	NEW 711165	TRZ	CU	1.969"	.590"	3.2MCC
TK374-0513	850513	TRZ	SI	3.0"	.250"	PO/FG 45 DEG
Phase shift mirrors						
TK374-3811	173811	PS	CU	2.756"	.984"	
TK374-7768	697768	PS	SI	3.0"	.236"	PO/FG 90 DEG

Optics care

Centricut part number	Reference number	Description	Pkg qty
TR300-6452	N/A	Lens cleaning paper, Tiffen – 50 piece	1
AM313-SC50	NEW SC50	Lens cleaning paper, Tresor – 50 piece	1
TR300-1115		Lens cleaning pre-cut cotton – 80 piece	1
TR300-SC20		Cotton swab – 20 piece	1
TR300-1010	AL1010	Dropper, lens cleaning fluid	1
TR300-255	AL255	Loupe, magnifying	1
TR300-271	AL271	Base, lens maintenance	1
TR300-7388	787388	Mirror polish (250 ml)	1
AM313-1260	NEW 351260-009	Lens Polarizing Filter – 1.5"	1
AM313-1280	NEW 351280-009	Lens Polarizing Filter – 2.0"	1

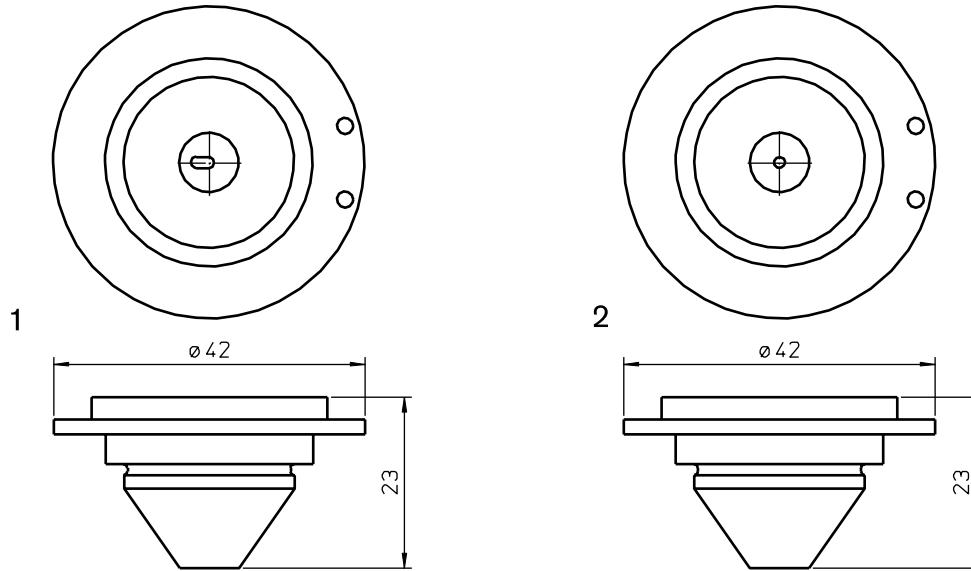

Consumables

	Centricut part number	Reference number	Alternate reference	Description	Pkg qty
1	TH424-0002		L1142	Nozzle (w/slot)	1
2	TH424-0001		L1143	Nozzle - 1.5 mm	1

Optics care

Centricut part number	Reference number	Description	Pkg qty
TR300-6452	N/A	Lens cleaning paper, Tiffen - 50 piece	1
AM313-SC50 NEW	SC50	Lens cleaning paper, Tresor - 50 piece	1
TR300-1115		Lens cleaning pre-cut cotton - 80 piece	1
TR300-SC20		Cotton swab - 20 piece	1
TR300-1010	AL1010	Dropper, lens cleaning fluid	1
TR300-255	AL255	Loupe, magnifying	1
TR300-271	AL271	Base, lens maintenance	1
TR300-7388	787388	Mirror polish (250 ml)	1
AM313-1260 NEW	351260-009	Lens Polarizing Filter - 1.5"	1
AM313-1280 NEW	351280-009	Lens Polarizing Filter - 2.0"	1

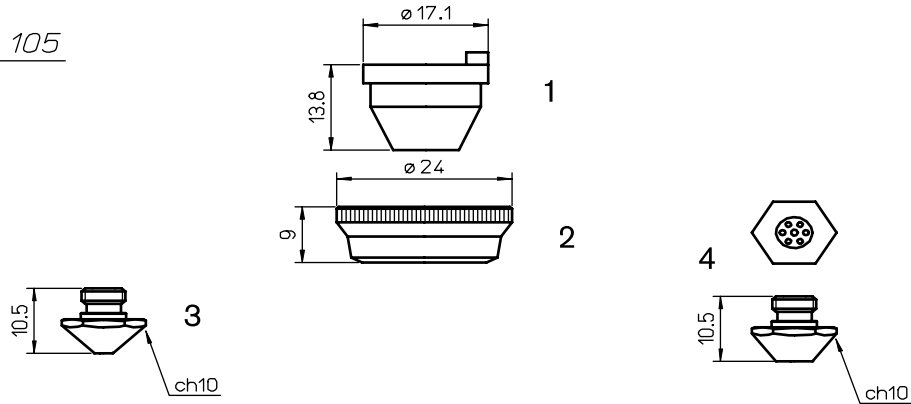
LASER TLC 105



Consumables

	Centricut part number	Reference number	Alternate reference	Description	Pkg qty
1	TR302-2405	280408, 092405	AL53	Nozzle holder - KT M1.5" KN (OEM)	1
2	TR352-0001	280550, P0494-940-00001	AL177	Ring - original (OEM)	1
3	TR302-6939	226939	L211	Nozzle - 1.0 mm	1
	TR302-6939X	226939	L40211	Nozzle - 1.0 mm (10 pack)	10
	TR302-0002		L212	Nozzle - 1.4 mm	1
	TR302-0002X		L40212	Nozzle - 1.4 mm (10 pack)	10
	TR302-0003		L213	Nozzle - 1.7 mm	1
	TR302-0003X		L40213	Nozzle - 1.7 mm (10 pack)	10
	TR302-6933CP	226939	L211X	Nozzle - 1.0 mm CP	1
	TR302-6933CPX	226939	L40211X	Nozzle - 1.0 mm CP (10 pack)	10
	TR302-0002CP		L212X	Nozzle - 1.4 mm CP	1
	TR302-0002CPX		L40212X	Nozzle - 1.4 mm CP (10 pack)	10
	TR302-0003CP		L213X	Nozzle - 1.7 mm CP	1
	TR302-0003CPX		L40213X	Nozzle - 1.7 mm CP (10 pack)	10
	TR302-0001		L214	Nozzle - 1.0 mm HD	1
	TR302-0001X		L40214	Nozzle - 1.0 mm HD (10 pack)	10
	TR302-6940	226940	L215	Nozzle - 1.4 mm HD	1
	TR302-6940X	226940	L40215	Nozzle - 1.4 mm HD (10 pack)	10
	TR302-7144	227144	L216	Nozzle - 1.7 mm HD	1
	TR302-7144X	227144	L40216	Nozzle - 1.7 mm HD (10 pack)	10
	TR302-0001CP		L214X	Nozzle - 1.0 mm HD CP	1
	TR302-0001CPX		L40214X	Nozzle - 1.0 mm HD CP (10 pack)	10
TR302-6949CP	226940	L215X	Nozzle - 1.4 mm HD CP	1	
TR302-6949CPX	226940	L40215X	Nozzle - 1.4 mm HD CP (10 pack)	10	
TR302-7144CP	227144	L216X	Nozzle - 1.7 mm HD CP	1	
TR302-7144CPX	227144	L40216X	Nozzle - 1.7 mm HD CP (10 pack)	10	
4	TR302-7364	237364	L395	Shower nozzle - 1.0 mm	1
	TR302-7364X	237364	L40395	Shower nozzle - 1.0 mm (10 pack)	10

LASER TLC 105

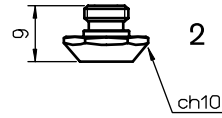
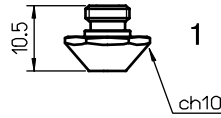

Consumables

	Centricut part number	Reference number	Alternate reference	Description	Pkg qty
1	TR302-4230	135420, 1354230	L1150	Nozzle - 0.8 mm	1
	TR302-4230X	135420, 1354230	L401150	Nozzle - 0.8 mm (10 pack)	10
	TR302-2334	212334	L255	Nozzle - 1.0 mm	1
	TR302-2334X	212334	L40255	Nozzle - 1.0 mm (10 pack)	10
	TR302-0008CP	135420, 1354230	L1150X	Nozzle - 0.8 mm CP	1
	TR302-0008CPX	135420, 1354230	L401150X	Nozzle - 0.8 mm CP (10 pack)	10
	TR302-2334CP	212334	L255X	Nozzle - 1.0 mm CP	1
	TR302-2334CPX	212334	L40255X	Nozzle - 1.0 mm CP (10 pack)	10
	TR302-0009		L1151	Nozzle - 0.8 mm HD	1
	TR302-0009X		L401151	Nozzle - 0.8 mm HD (10 pack)	10
	TR302-0004		L270	Nozzle - 1.0 mm HD	1
	TR302-0004X		L40270	Nozzle - 1.0 mm HD (10 pack)	10
	TR302-6199	216199	L256	Nozzle - 1.4 mm HD	1
	TR302-6199X	216199	L40256	Nozzle - 1.4 mm HD (10 pack)	10
	TR302-5213	225213	L257	Nozzle - 1.7 mm HD	1
	TR302-5213X	225213	L40257	Nozzle - 1.7 mm HD (10 pack)	10
	TR302-6156	126156	L277	Nozzle - 2.3 mm HD	1
	TR302-6156X	126156	L40277	Nozzle - 2.3 mm HD (10 pack)	10
	TR302-0027		L1152	Nozzle - 2.7 mm HD	1
	TR302-0027X		L401152	Nozzle - 2.7 mm HD (10 pack)	10
	TR302-0009CP		L1151X	Nozzle - 0.8 mm HD CP	1
	TR302-0009CPX		L401151X	Nozzle - 0.8 mm HD CP (10 pack)	10
	TR302-0004CP		L270X	Nozzle - 1.0 mm HD CP	1
	TR302-0004CPX		L40270X	Nozzle - 1.0 mm HD CP (10 pack)	10
	TR302-6198 NEW		L1154	Nozzle - 1.2 mm HD	1
	TR302-6198X NEW		L401154	Nozzle - 1.2 mm HD (10 pack)	10
	TR302-6199CP	216199	L256X	Nozzle - 1.4 mm HD CP	1
	TR302-6199CPX	216199	L40256X	Nozzle - 1.4 mm HD CP (10 pack)	10
	TR302-5213CP	225213	L257X	Nozzle - 1.7 mm HD CP	1
	TR302-5213CPX	225213	L40257X	Nozzle - 1.7 mm HD CP (10 pack)	10
	TR302-6156CP	126156	L277X	Nozzle - 2.3 mm HD CP	1
	TR302-6156CPX	126156	L40277X	Nozzle - 2.3 mm HD CP (10 pack)	10
TR302-0027CP		L1152X	Nozzle - 2.7 mm HD CP	1	
TR302-0027CPX		L401152X	Nozzle - 2.7 mm HD CP (10 pack)	10	
2	TR302-0005		L278	Nozzle - short - 2.3 mm HD H=4	1
	TR302-0005X		L40278	Nozzle - short - 2.3 mm HD H=4 (10 pack)	10
	TR302-0006		L332	Nozzle - short - 2.3 mm HD H=3.5	1
	TR302-0006X		L40332	Nozzle - short - 2.3 mm HD H=3.5 (10 pack)	10

LASER TLC 105

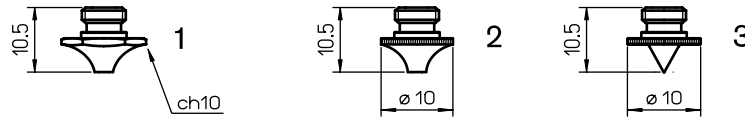

Consumables

	Centricut part number	Reference number	Alternate reference	Description	Pkg qty
1	TR302-5320		L625	Nozzle - 1.0 mm	1
	TR302-5320X		L40625	Nozzle - 1.0 mm (10 pack)	10
	TR302-5320CP		L625X	Nozzle - 1.0 mm CP	1
	TR302-5320CPX		L40625X	Nozzle - 1.0 mm CP (10 pack)	10
	TR302-0007		L627	Nozzle - 1.0 mm HD	1
	TR302-0007X		L40627	Nozzle - 1.0 mm HD (10 pack)	10
	TR302-5318		L628	Nozzle - 1.4 mm HD	1
	TR302-5318X		L40628	Nozzle - 1.4 mm HD (10 pack)	10
	TR302-0017		L629	Nozzle - 1.7 mm HD	1
	TR302-0017X		L40629	Nozzle - 1.7 mm HD (10 pack)	10
	TR302-0007CP		L627X	Nozzle - 1.0 mm HD CP	1
	TR302-0007CPX		L40627X	Nozzle - 1.0 mm HD CP (10 pack)	10
	TR302-5318CP		L628X	Nozzle - 1.4 mm HD CP	1
	TR302-5318CPX		L40628X	Nozzle - 1.4 mm HD CP (10 pack)	10
TR302-0017CP		L629X	Nozzle - 1.7 mm HD CP	1	
TR302-0017CPX		L40629X	Nozzle - 1.7 mm HD CP (10 pack)	10	
2	TR302-0025		L746	Nozzle - 0.25 mm HD	1
	TR302-0025X		L40746	Nozzle - 0.25 mm HD (10 pack)	10
	TR302-0010	135320	L267	Nozzle - 1.0 mm HD	1
	TR302-0010X	135320	L40267	Nozzle - 1.0 mm HD (10 pack)	10
	TR302-0012		L1153	Nozzle - 1.2 mm HD	1
	TR302-0012X		L401153	Nozzle - 1.2 mm HD (10 pack)	10
	TR302-0014	135318	L268	Nozzle - 1.4 mm HD	1
	TR302-0014X	135318	L40268	Nozzle - 1.4 mm HD (10 pack)	10
	TR302-6157	126157	L269	Nozzle - 1.7 mm HD	1
	TR302-6157X	126157	L40269	Nozzle - 1.7 mm HD (10 pack)	10
	TR302-0010CP	135320	L267X	Nozzle - 1.0 mm HD CP	1
	TR302-0010CPX	135320	L40267X	Nozzle - 1.0 mm HD CP (10 pack)	10
	TR302-0012CP		L1153X	Nozzle - 1.2 mm HD CP	1
	TR302-0012CPX		L401153X	Nozzle - 1.2 mm HD CP (10 pack)	10
	TR302-0014CP	135318	L268X	Nozzle - 1.4 mm HD CP	1
	TR302-0014CPX	135318	L40268X	Nozzle - 1.4 mm HD CP (10 pack)	10
TR302-0157CP	126157	L269X	Nozzle - 1.7 mm HD CP	1	
TR302-0157CPX	126157	L40269X	Nozzle - 1.7 mm HD CP (10 pack)	10	
3	TR302-0747		L747	Nozzle - Sharp tip	1

LASER TLC 1005

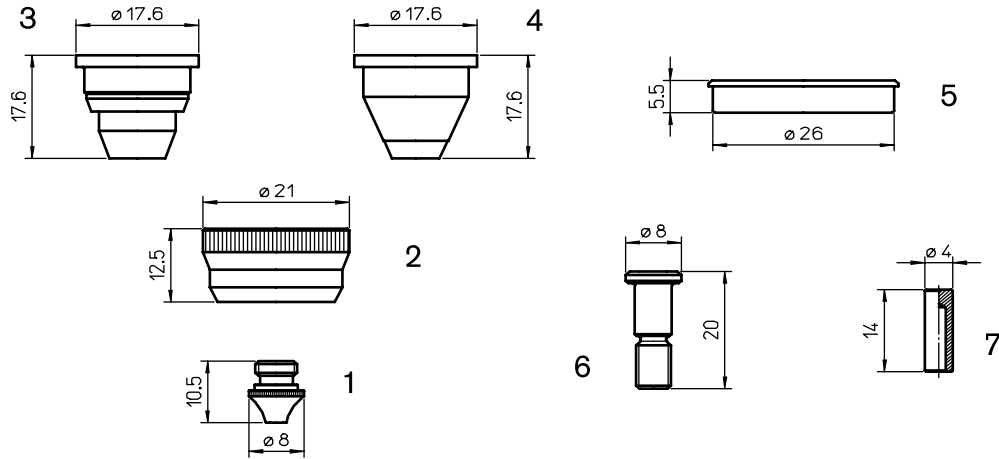

Consumables

	Centricut part number	Reference number	Alternate reference	Description	Pkg qty
	TR302-8206	958206	L745	Nozzle - 0.25 mm HD	1
	TR302-8206X	958206	L40745	Nozzle - 0.25 mm HD (10 pack)	10
	TR352-3799	913799	L500	Nozzle - 0.8 mm HD	1
	TR352-3799X	913799	L40500	Nozzle - 0.8 mm HD (10 pack)	10
	TR352-3800	913800	L501	Nozzle - 1.0 mm HD	1
	TR352-3800X	913800	L40501	Nozzle - 1.0 mm HD (10 pack)	10
	TR352-7034	1487034	L498	Nozzle - 1.2 mm HD	1
	TR352-7034X	1487034	L40498	Nozzle - 1.2 mm HD (10 pack)	10
	TR352-3801	913801	L502	Nozzle - 1.4 mm HD	1
	TR352-3801X	913801	L40502	Nozzle - 1.4 mm HD (10 pack)	10
	TR352-7988	937988	L503	Nozzle - 1.7 mm HD	1
	TR352-7988X	937988	L40503	Nozzle - 1.7 mm HD (10 pack)	10
	TR352-7991		L499	Nozzle - 1.75 mm HD	1
	TR352-7991X		L40499	Nozzle - 1.75 mm HD (10 pack)	10
	TR352-7990		L508	Nozzle - 2.0 mm HD	1
	TR352-7990X		L40508	Nozzle - 2.0 mm HD (10 pack)	10
1	TR352-7989	937989	L504	Nozzle - 2.3 mm HD	1
	TR352-7989X	937989	L40504	Nozzle - 2.3 mm HD (10 pack)	10
	TR352-3799CP	913799	L500X	Nozzle - 0.8 mm HD CP	1
	TR352-3799CPX	913799	L40500X	Nozzle - 0.8 mm HD CP (10 pack)	10
	TR352-3800CP	913800	L501X	Nozzle - 1.0 mm HD CP	1
	TR352-3800CPX	913800	L40501X	Nozzle - 1.0 mm HD CP (10 pack)	10
	TR352-7034CP	1487034	L498X	Nozzle - 1.2 mm HD CP	1
	TR352-7034CPX	1487034	L40498X	Nozzle - 1.2 mm HD CP (10 pack)	10
	TR352-3801CP	913801	L502X	Nozzle - 1.4 mm HD CP	1
	TR352-3801CPX	913801	L40502X	Nozzle - 1.4 mm HD CP (10 pack)	10
	TR352-7988CP	937988	L503X	Nozzle - 1.7 mm HD CP	1
	TR352-7988CPX	937988	L40503X	Nozzle - 1.7 mm HD CP (10 pack)	10
	TR352-7990CP		L508X	Nozzle - 2.0 mm HD CP	1
	TR352-7990CPX		L40508X	Nozzle - 2.0 mm HD CP (10 pack)	10
	TR352-7989CP	937989	L504X	Nozzle - 2.3 mm HD CP	1
	TR352-7989CPX	937989	L40504X	Nozzle - 2.3 mm HD CP (10 pack)	10
2	TR352-3965	913965	AL254	Retainer nut	1
3	TR302-6678C	936678, 913966/00-WO	AL412	Nozzle holder - ceramic	1
4	TR302-6678	936678, 913966/00-WO	AL212	Nozzle holder - ceramic	1
5	TR302-0354	960354	AL389	Insulator - PTFE*	1
6	TR352-1734	971734	AL264	Safety screw	1
7	TR352-1878	971878	AL265	Dowl pin	1

*PolyTetraFluoroEthylene is a fluorocarbon-based polymer and is commonly abbreviated PTFE. The Teflon® brand of PTFE is manufactured only by DuPont and is not sold by Hypertherm. Hypertherm purchases other brands of PTFE from various high quality manufacturers.

TLF 6003

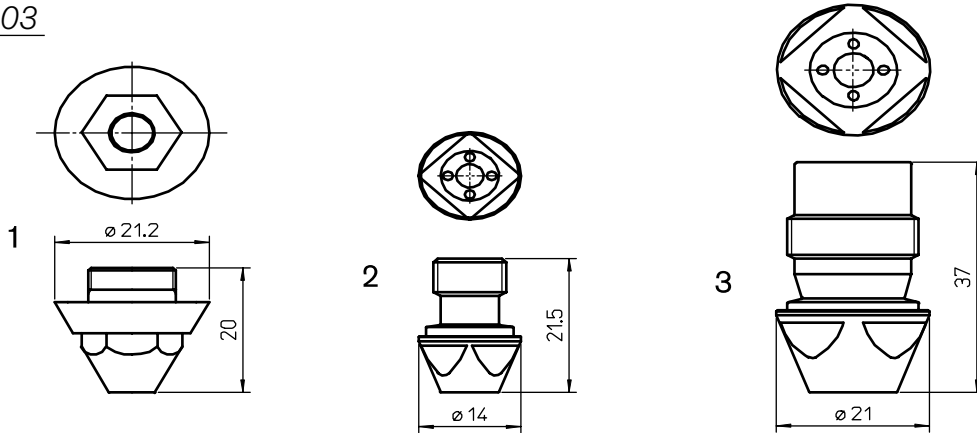

Consumables

	Centricut part number	Reference number	Alternate reference	Description	Pkg qty
1	TR352-2530CP	932530	L1010X	Nozzle - 4.5 mm CP	1
2	TR352-4947	924947	L1185	Nozzle - welding M10	1
3	TR352-0783	220783	L1186	Nozzle - welding M18	1

TESTA YH27

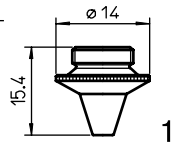

YAG

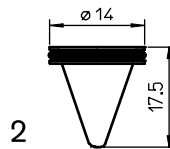

Consumables

	Centricut part number	Reference number	Alternate reference	Description	Pkg qty
1	PT344-1813	281813, P0589-424-00008	L405	Nozzle - 0.8 mm	1
	PT344-1813X	281813, P0589-424-00008	L30405	Nozzle - 0.8 mm (10 pack)	10
	PT344-1789	281789, P0589-426-00010	L406	Nozzle - 1.0 mm	1
	PT344-1789X	281789, P0589-426-00010	L30406	Nozzle - 1.0 mm (10 pack)	10
	PT344-1561	281561, 778550	L404	Nozzle - 1.2 mm	1
	PT344-1561X	281561, 778550	L30404	Nozzle - 1.2 mm (10 pack)	10
	PT344-1499	281814, 149957	L407	Nozzle - 1.5 mm	1
	PT344-1499X	281814, 149957	L30407	Nozzle - 1.5 mm (10 pack)	10
	PT344-0020	P0589-428-00020	L408	Nozzle - 2.0 mm	1
	PT344-0020X	P0589-428-00020	L30408	Nozzle - 2.0 mm (10 pack)	10
	PT344-1813CP	281813, P0589-424-00008	L405X	Nozzle - 0.8 mm CP	1
	PT344-1813CPX	281813, P0589-424-00008	L30405X	Nozzle - 0.8 mm CP (10 pack)	10
	PT344-1789CP	281789, P0589-426-00010	L406X	Nozzle - 1.0 mm CP	1
	PT344-1789CPX	281789, P0589-426-00010	L30406X	Nozzle - 1.0 mm CP (10 pack)	10
	PT344-1561CP	281561, 778550, P0589-425-00012	L404X	Nozzle - 1.2 mm CP	1
	PT344-1561CPX	281561, 778550	L30404X	Nozzle - 1.2 mm CP (10 pack)	10
	PT344-1499CP	281814, 149957	L407X	Nozzle - 1.5 mm CP	1
	PT344-1499CPX	281814, 149957	L30407X	Nozzle - 1.5 mm CP (10 pack)	10
	PT344-0020CP	P0589-428-00020	L408X	Nozzle - 2.0 mm CP	1
	PT344-0020CPX	P0589-428-00020	L30408X	Nozzle - 2.0 mm CP (10 pack)	10
2	TR414-0008	12-11-16-00	L507	Nozzle - 0.8 mm Yag w/o-ring	1
	TR414-0010		L506	Nozzle - 1.0 mm Yag w/o-ring	1
	TR414-0012	12-11-09-17/00	L505	Nozzle - 1.2 mm Yag w/o-ring	1

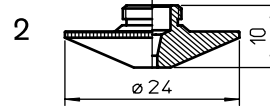
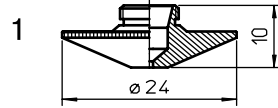

Consumables

	Centricut part number	Reference number	Alternate reference	Description	Pkg qty
1	TR301-4561	124561, 237499	L18	Nozzle - 0.8 mm	1
	TR301-4561X	124561, 237499	L3018	Nozzle - 0.8 mm (10 pack)	10
	TR301-4562	124562, 237498	L19	Nozzle - 1.0 mm	1
	TR301-4562X	124562, 237498	L3019	Nozzle - 1.0 mm (10 pack)	10
	TR301-6809	966809	L361	Nozzle - 1.2 mm	1
	TR301-6809X	966809	L30361	Nozzle - 1.2 mm (10 pack)	10
	TR301-0014		L795	Nozzle - 1.4 mm	1
	TR301-0014X		L30795	Nozzle - 1.4 mm (10 pack)	10
	TR301-7500	237500	L26	Nozzle - 1.5 mm	1
	TR301-7500X	237500	L3026	Nozzle - 1.5 mm (10 pack)	10
	TR301-0017		L796	Nozzle - 1.7 mm	1
	TR301-0017X		L30796	Nozzle - 1.7 mm (10 pack)	10
	TR301-7503	237503	L24	Nozzle - 2.0 mm	1
	TR301-7503X	237503	L3024	Nozzle - 2.0 mm (10 pack)	10
	TR301-4564	124564	L797	Nozzle - 2.3 mm	1
	TR301-4564X	124564	L30797	Nozzle - 2.3 mm (10 pack)	10
	TR301-7504	237504	L25	Nozzle - 3.0 mm	1
	TR301-7504X	237504	L3025	Nozzle - 3.0 mm (10 pack)	10
	TR301-0561CP	352280	L18X	Nozzle - 0.8 mm CP	1
	TR301-0561CPX	352280	L3018X	Nozzle - 0.8 mm CP (10 pack)	10
	TR301-0562CP	352281	L19X	Nozzle - 1.0 mm CP	1
	TR301-0562CPX	352281	L3019X	Nozzle - 1.0 mm CP (10 pack)	10
	TR301-0809CP	352282	L361X	Nozzle - 1.2 mm CP	1
	TR301-0809CPX	352282	L30361X	Nozzle - 1.2 mm CP (10 pack)	10
	TR301-0014CP		L795X	Nozzle - 1.4 mm CP	1
	TR301-0014CPX		L30795X	Nozzle - 1.4 mm CP (10 pack)	10
	TR301-7500CP	352288	L26X	Nozzle - 1.5 mm CP	1
	TR301-7500CPX	352288	L3026X	Nozzle - 1.5 mm CP (10 pack)	10
	TR301-0017CP		L796X	Nozzle - 1.7 mm CP	1
	TR301-0017CPX		L30796X	Nozzle - 1.7 mm CP (10 pack)	10
	TR301-7503CP		L24X	Nozzle - 2.0 mm CP	1
	TR301-7503CPX		L3024X	Nozzle - 2.0 mm CP (10 pack)	10
TR301-4564CP	124564	L797X	Nozzle - 2.3 mm CP	1	
TR301-4564CPX	124564	L30797X	Nozzle - 2.3 mm CP (10 pack)	10	
TR301-7504CP	237504	L25X	Nozzle - 3.0 mm CP	1	
TR301-7504CPX		L3025X	Nozzle - 3.0 mm CP (10 pack)	10	
2	TR301-7497	237497	L20	Nozzle - 1.4 mm HD	1
	TR301-7497X	237497	L3020	Nozzle - 1.4 mm HD (10 pack)	10
	TR301-1497CP	352283	L20X	Nozzle - 1.4 mm HD CP	1
	TR301-1497CPX	352283	L3020X	Nozzle - 1.4 mm HD CP (10 pack)	10

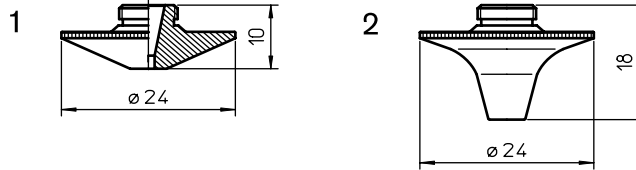

Consumables

	Centricut part number	Reference number	Alternate reference	Description	Pkg qty	
1	TR301-7497-S	237497/S	L258	Nozzle - 1.4 mm HD	1	
	TR301-0497X	237497/S	L30258	Nozzle - 1.4 mm HD (10 pack)	10	
	TR301-7501	237501	L21	Nozzle - 1.7 mm HD	1	
	TR301-7501X	237501	L3021	Nozzle - 1.7 mm HD (10 pack)	10	
	TR301-3211	237502	L168	Nozzle - 2.0 mm HD	1	
	TR301-3211X	237502	L30168	Nozzle - 2.0 mm HD (10 pack)	10	
	TR301-6933	126933	L76	Nozzle - 2.3 mm HD	1	
	TR301-6933X	126933	L3076	Nozzle - 2.3 mm HD (10 pack)	10	
	TR301-0003		L185	Nozzle - 2.5 mm HD	1	
	TR301-0003X		L30185	Nozzle - 2.5 mm HD (10 pack)	10	
	TR301-2742	942742	L360	Nozzle - 2.7 mm HD	1	
	TR301-2742X	942742	L30360	Nozzle - 2.7 mm HD (10 pack)	10	
	TR301-0004		L396	Nozzle - 3.0 mm HD	1	
	TR301-0004X		L30396	Nozzle - 3.0 mm HD (10 pack)	10	
	TR301-0497CP	237497/S	L258X	Nozzle - 1.4 mm HD CP	1	
	TR301-0497CPX		L30258X	Nozzle - 1.4 mm HD CP (10 pack)	10	
	TR301-0501CP	352284	L21X	Nozzle - 1.7 mm HD CP	1	
	TR301-0501CPX	352284	L3021X	Nozzle - 1.7 mm HD CP (10 pack)	10	
	TR301-1002CP	352287	L168X	Nozzle - 2.0 mm HD CP	1	
	TR301-1002CPX	352287	L30168X	Nozzle - 2.0 mm HD CP (10 pack)	10	
	TR301-0933CP	352285	L76X	Nozzle - 2.3 mm HD CP	1	
	TR301-0933CPX	352285	L3076X	Nozzle - 2.3 mm HD CP (10 pack)	10	
	TR301-0003CP		L185X	Nozzle - 2.5 mm HD CP	1	
	TR301-0003CPX		L30185X	Nozzle - 2.5 mm HD CP (10 pack)	10	
	TR301-0742CP	352286	L360X	Nozzle - 2.7 mm HD CP	1	
	TR301-0742CPX	352286	L30360X	Nozzle - 2.7 mm HD CP (10 pack)	10	
	TR301-1004CP		L396X	Nozzle - 3.0 mm HD CP	1	
	TR301-1004CPX		L30396X	Nozzle - 3.0 mm HD CP (10 pack)	10	
	2	TR301-7773	1277773	L1550	Nozzle - 0.8 mm	1
		TR301-7771	1277771	L1551	Nozzle - 1.0 mm	1
		TR301-7774	1277774	L1552	Nozzle - 1.2 mm	1
		TR301-7776	1277776	L1553	Nozzle - 1.4 mm	1
TR301-7779		1277779	L1554	Nozzle - 1.7 mm	1	
TR301-7780		1277780	L1555	Nozzle - 2.0 mm	1	
TR301-7781		1277781	L1556	Nozzle - 2.3 mm	1	
TR301-7782		1277782	L1557	Nozzle - 2.7 mm	1	
TR301-7773CP			L1550X	Nozzle - 0.8 mm CP	1	
TR301-7771CP			L1551X	Nozzle - 1.0 mm CP	1	
TR301-7774CP			L1552X	Nozzle - 1.2 mm CP	1	
TR301-7776CP			L1553X	Nozzle - 1.4 mm CP	1	
TR301-7779CP			L1554X	Nozzle - 1.7 mm CP	1	
TR301-7780CP			L1555X	Nozzle - 2.0 mm CP	1	
TR301-7781CP			L1556X	Nozzle - 2.3 mm CP	1	
TR301-7782CP			L1557X	Nozzle - 2.7 mm CP	1	

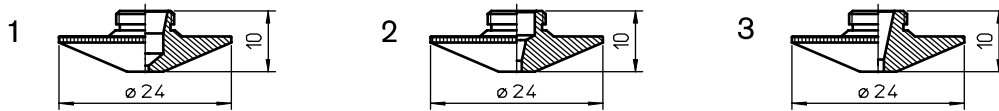

Consumables

	Centricut part number	Reference number	Alternate reference	Description	Pkg qty
1	TR301-4561CP	352280	L18XH	Nozzle - 0.8 mm hard CP	1
	TR301-4561CPX	352280	L3018XH	Nozzle - 0.8 mm hard CP (10 pack)	10
	TR301-4562CP	352281	L19XH	Nozzle - 1.0 mm hard CP	1
	TR301-4562CPX	352281	L3019XH	Nozzle - 1.0 mm hard CP (10 pack)	10
	TR301-6809CP	352282	L361XH	Nozzle - 1.2 mm hard CP	1
	TR301-6809CPX	352282	L30361XH	Nozzle - 1.2 mm hard CP (10 pack)	10
2	TR301-7497CP	352283	L20XH	Nozzle - 1.4 mm HD hard CP	1
	TR301-7497CPX	352283	L3020XH	Nozzle - 1.4 mm HD hard CP (10 pack)	10
3	TR301-0014HCP		L258XH	Nozzle - 1.4 mm HD hard CP	1
	TR301-0014HCPX		L30258XH	Nozzle - 1.4 mm HD hard CP (10 pack)	10
	TR301-7501CP	352284	L21XH	Nozzle - 1.7 mm HD hard CP	1
	TR301-7501CPX	352284	L3021XH	Nozzle - 1.7 mm HD hard CP (10 pack)	10
	TR301-0002CP	352287	L168XH	Nozzle - 2.0 mm HD hard CP	1
	TR301-0002CPX	237502	L30168XH	Nozzle - 2.0 mm HD hard CP (10 pack)	10
	TR301-6933CP	352285	L76XH	Nozzle - 2.3 mm HD hard CP	1
	TR301-6933CPX	352285	L3076XH	Nozzle - 2.3 mm HD hard CP (10 pack)	10
	TR301-0025HCP		L185XH	Nozzle - 2.5 mm HD hard CP	1
	TR301-0025HCPX		L30185XH	Nozzle - 2.5 mm HD hard CP (10 pack)	10
	TR301-2742CP	352286	L360XH	Nozzle - 2.7 mm HD hard CP	1
	TR301-2742CPX	352286	L30360XH	Nozzle - 2.7 mm HD hard CP (10 pack)	10
	TR301-0004CP		L396XH	Nozzle - 3.0 mm HD hard CP	1
	TR301-0004CPX		L30396XH	Nozzle - 3.0 mm HD hard CP (10 pack)	10

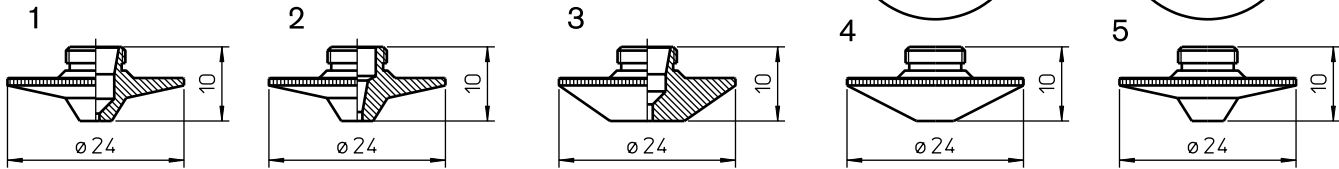

Consumables

	Centricut part number	Reference number	Alternate reference	Description	Pkg qty
1	TR301-5780	215780	L2	Nozzle - 0.8 mm	1
	TR301-5780X	215780	L3002	Nozzle - 0.8 mm (10 pack)	10
	TR301-7658	87658	L11	Nozzle - 1.0 mm	1
	TR301-7658X	87658	L3011	Nozzle - 1.0 mm (10 pack)	10
	TR301-5780CP	215780	L2X	Nozzle - 0.8 mm CP	1
	TR301-5780CPX	215780	L3002X	Nozzle - 0.8 mm CP (10 pack)	10
	TR301-7658CP	87658	L11X	Nozzle - 1.0 mm CP	1
	TR301-7658CPX	87658	L3011X	Nozzle - 1.0 mm CP (10 pack)	10
2	TR301-8894	88894	L1	Nozzle - 1.4 mm HD	1
	TR301-8894X	88894	L3001	Nozzle - 1.4 mm HD (10 pack)	10
	TR301-7867	217867	L12	Nozzle - 1.7 mm HD	1
	TR301-7867X	217867	L3012	Nozzle - 1.7 mm HD (10 pack)	10
3	TR301-1010		L798	Nozzle - 1.0 mm	1
	TR301-1010X		L30798	Nozzle - 1.0 mm (10 pack)	10
	TR301-8893	88893	L13	Nozzle - 1.5 mm	1
	TR301-8893X	88893	L3013	Nozzle - 1.5 mm (10 pack)	10
	TR301-1781	221781	L68	Nozzle - 2.0 mm	1
	TR301-1781X	221781	L3068	Nozzle - 2.0 mm (10 pack)	10
	TR301-4565	235592	L230	Nozzle - 3.0 mm	1
	TR301-4565X	235592	L30230	Nozzle - 3.0 mm (10 pack)	10
4	TR301-7872	237872	L495	Shower nozzle - 0.8 mm	1
	TR301-7872X	237872	L30495	Shower nozzle - 0.8 mm (10 pack)	10
5	TR301-7976	217976	L496	Shower nozzle - 0.8 mm	1
	TR301-7976X	217976	L30496	Shower nozzle - 0.8 mm (10 pack)	10

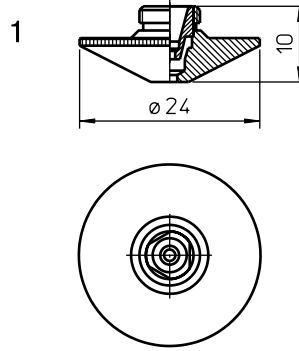

Consumables

	Centricut part number	Reference number	Alternate reference	Description	Pkg qty
	TR355-0005	Centricut design	L640	Nozzle - 0.8 mm double	1
	TR355-0005X	Centricut design	L30640	Nozzle - 0.8 mm double (10 pack)	10
	TR355-0001	Centricut design	L641	Nozzle - 1.0 mm double	1
	TR355-0001X	Centricut design	L30641	Nozzle - 1.0 mm double (10 pack)	10
	TR355-0006	Centricut design	L648	Nozzle - 1.2 mm double	1
	TR355-0006X	Centricut design	L30648	Nozzle - 1.2 mm double (10 pack)	10
	TR355-0002	Centricut design	L642	Nozzle - 1.4 mm double	1
	TR355-0002X	Centricut design	L30642	Nozzle - 1.4 mm double (10 pack)	10
	TR355-0003	Centricut design	L643	Nozzle - 1.7 mm double	1
	TR355-0003X	Centricut design	L30643	Nozzle - 1.7 mm double (10 pack)	10
	TR355-0007	Centricut design	L644	Nozzle - 2.0 mm double	1
	TR355-0007X	Centricut design	L30644	Nozzle - 2.0 mm double (10 pack)	10
	TR355-0004	Centricut design	L645	Nozzle - 2.3 mm double	1
	TR355-0004X	Centricut design	L30645	Nozzle - 2.3 mm double (10 pack)	10
	TR355-0008	Centricut design	L646	Nozzle - 2.7 mm double	1
	TR355-0008X	Centricut design	L30646	Nozzle - 2.7 mm double (10 pack)	10
	TR355-0009	Centricut design	L647	Nozzle - 3.0 mm double	1
	TR355-0009X	Centricut design	L30647	Nozzle - 3.0 mm double (10 pack)	10
1	TR355-0005CP	Centricut design	L640X	Nozzle - 0.8 mm double CP	1
	TR355-0005CPX	Centricut design	L30640X	Nozzle - 0.8 mm double CP (10 pack)	10
	TR355-0001CP	Centricut design	L641X	Nozzle - 1.0 mm double CP	1
	TR355-0001CPX	Centricut design	L30641X	Nozzle - 1.0 mm double CP (10 pack)	10
	TR355-0006CP	Centricut design	L648X	Nozzle - 1.2 mm double CP	1
	TR355-0006CPX	Centricut design	L30648X	Nozzle - 1.2 mm double CP (10 pack)	10
	TR355-0002CP	Centricut design	L642X	Nozzle - 1.4 mm double CP	1
	TR355-0002CPX	Centricut design	L30642X	Nozzle - 1.4 mm double CP (10 pack)	10
	TR355-0003CP	Centricut design	L643X	Nozzle - 1.7 mm double CP	1
	TR355-0003CPX	Centricut design	L30643X	Nozzle - 1.7 mm double CP (10 pack)	10
	TR355-0007CP	Centricut design	L644X	Nozzle - 2.0 mm double CP	1
	TR355-0007CPX	Centricut design	L30644X	Nozzle - 2.0 mm double CP (10 pack)	10
	TR355-0004CP	Centricut design	L645X	Nozzle - 2.3 mm double CP	1
	TR355-0004CPX	Centricut design	L30645X	Nozzle - 2.3 mm double CP (10 pack)	10
	TR355-0008CP	Centricut design	L646X	Nozzle - 2.7 mm double CP	1
	TR355-0008CPX	Centricut design	L30646X	Nozzle - 2.7 mm double CP (10 pack)	10
	TR355-0009CP	Centricut design	L647X	Nozzle - 3.0 mm double CP	1
	TR355-0009CPX	Centricut design	L30647X	Nozzle - 3.0 mm double CP (10 pack)	10
	TR355-0010CP	Centricut design	L649X	Nozzle - 4.0 mm double CP	1

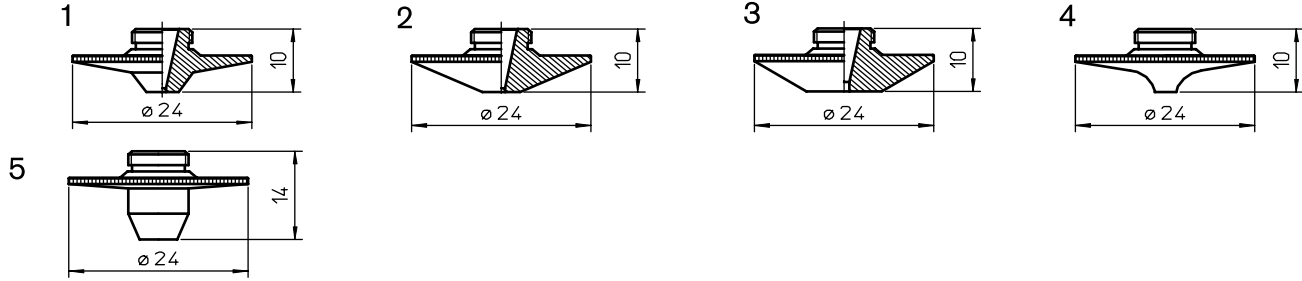

Consumables

	Centricut part number	Reference number	Alternate reference	Description	Pkg qty
1	TR412-0008	Centricut design	L226	Nozzle - 0.8 mm HD	1
	TR412-0008X	Centricut design	L30226	Nozzle - 0.8 mm HD (10 pack)	10
	TR412-0010	Centricut design	L181	Nozzle - 1.0 mm HD	1
	TR412-0010X	Centricut design	L30181	Nozzle - 1.0 mm HD (10 pack)	10
	TR412-0014	Centricut design	L182	Nozzle - 1.4 mm HD	1
	TR412-0014X	Centricut design	L30182	Nozzle - 1.4 mm HD (10 pack)	10
	TR412-0017	Centricut design	L227	Nozzle - 1.7 mm HD	1
	TR412-0017X	Centricut design	L30227	Nozzle - 1.7 mm HD (10 pack)	10
	TR301-0001	Centricut design	L313	Nozzle - 2.3 mm HD	1
	TR301-0001X	Centricut design	L30313	Nozzle - 2.3 mm HD (10 pack)	10
2	TR412-0001	Centricut design	L228	Nozzle - 0.8 mm HD	1
	TR412-0001X	Centricut design	L30228	Nozzle - 0.8 mm HD (10 pack)	10
	TR412-0011	Centricut design	L180	Nozzle - 1.0 mm HD	1
	TR412-0011X	Centricut design	L30180	Nozzle - 1.0 mm HD (10 pack)	10
3	TR412-0015	Centricut design	L232	Nozzle - 1.5 mm HD	1
	TR412-0015X	Centricut design	L30232	Nozzle - 1.5 mm HD (10 pack)	10
	TR412-0020	Centricut design	L233	Nozzle - 2.0 mm HD	1
	TR412-0020X	Centricut design	L30233	Nozzle - 2.0 mm HD (10 pack)	10
4	TR412-0023	Centricut design	L720	Nozzle - 2.3 mm HD	1
	TR412-0023X	Centricut design	L30720	Nozzle - 2.3 mm HD (10 pack)	10
	TR412-0025	Centricut design	L721	Nozzle - 2.5 mm HD	1
	TR412-0025X	Centricut design	L30721	Nozzle - 2.5 mm HD (10 pack)	10
	TR412-0027	Centricut design	L722	Nozzle - 2.7 mm HD	1
	TR412-0027x	Centricut design	L30722	Nozzle - 2.7 mm HD (10 pack)	10
	TR412-2323	Centricut design	L671	Nozzle - 2.3 mm HD economy gas	1
	TR412-2323X	Centricut design	L30671	Nozzle - 2.3 mm HD economy gas (10 pack)	10
	TR412-1014CP	Centricut design	L1034X	Nozzle - 1.4 mm HD CP	1
	TR412-1014CPX	Centricut design	L301034X	Nozzle - 1.4 mm HD CP (10 pack)	10
	TR412-1017CP	Centricut design	L1035X	Nozzle - 1.7 mm HD CP	1
	TR412-1017CPX	Centricut design	L301035X	Nozzle - 1.7 mm HD CP (10 pack)	10
	TR412-1023CP	Centricut design	L720X	Nozzle - 2.3 mm HD CP	1
	TR412-1023CPX	Centricut design	L30720X	Nozzle - 2.3 mm HD CP (10 pack)	10
	TR412-1025CP	Centricut design	L721X	Nozzle - 2.5 mm HD CP	1
	TR412-1025CPX	Centricut design	L30721X	Nozzle - 2.5 mm HD CP (10 pack)	10
	TR412-1027CP	Centricut design	L722X	Nozzle - 2.7 mm HD CP	1
TR412-1027CPX	Centricut design	L30722X	Nozzle - 2.7 mm HD CP (10 pack)	10	
5	TR415-0008	Centricut design	L200	Nozzle - 0.8 mm extended	1
	TR415-0010	Centricut design	L199	Nozzle - 1.0 mm extended	1
	TR415-0012	Centricut design	L657	Nozzle - 1.2 mm extended	1
	TR415-0014	Centricut design	L658	Nozzle - 1.4 mm extended	1
	TR415-0016	Centricut design	L670	Nozzle - 1.6 mm extended	1
	TR415-0017	Centricut design	L659	Nozzle - 1.7 mm extended	1

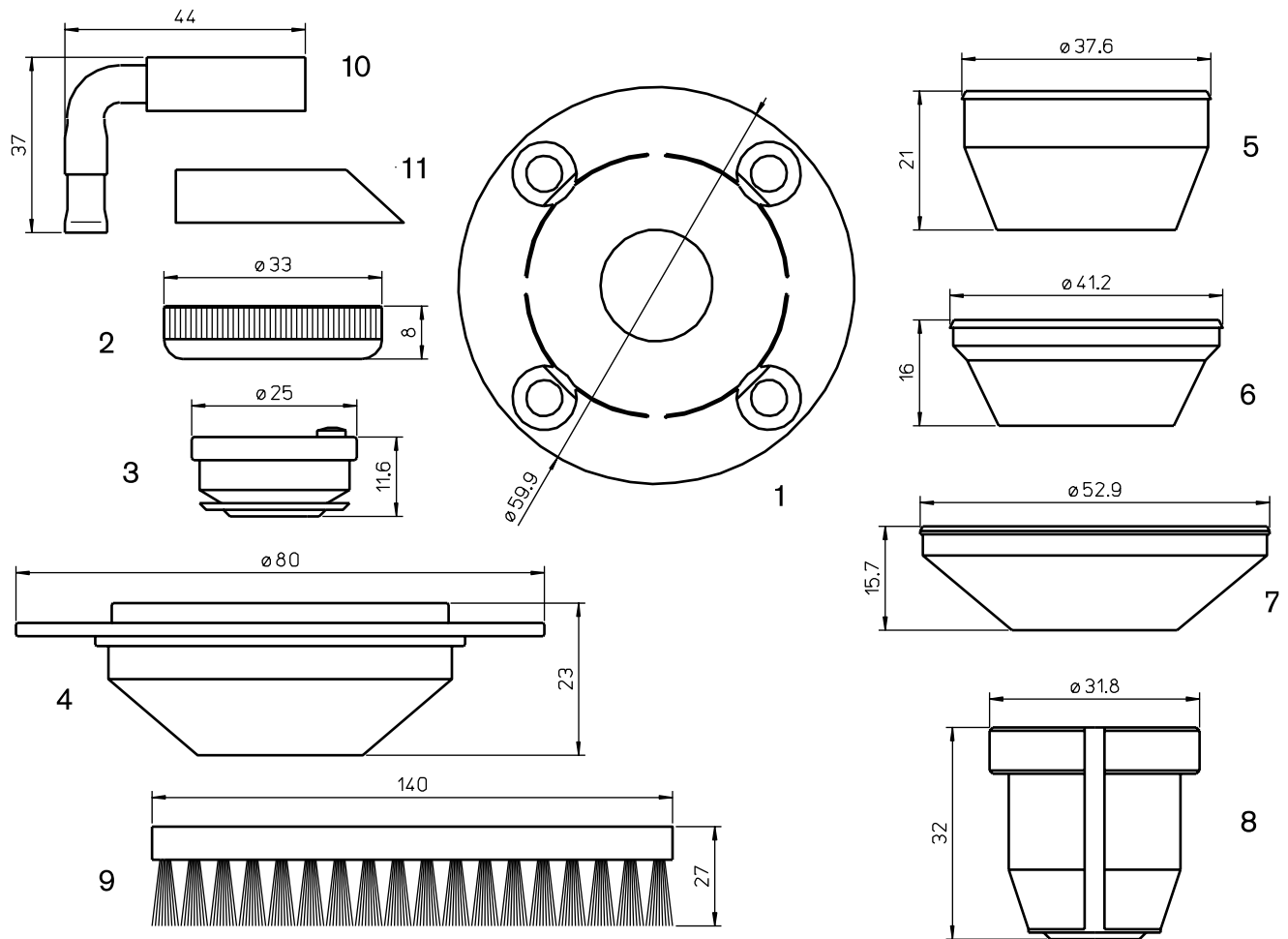

Consumables

	Centricut part number	Reference number	Alternate reference	Description	Pkg qty
1	TR301-4485	234485	AL70	Break-away plate	1
2	TR301-6066	216066	AL250	Signboard	1
3	TR301-8809	258809, 243839, 247894	AL38	Nozzle holder - ceramic	1
	TR301-8809OEM NEW	258809		Nozzle holder - ceramic - OEM	1
4	TR301-6065	216065	AL19	Cover, PTFE*	1
5	TR301-6153	256153, 955826	AL47	Cover, PTFE* (white)	1
	TR301-6153T	256153, 955826	AL347	Cover, PTFE* (black)	1
6	TR301-4496	254496	AL36	Cover, PTFE*	1
7	TR301-5286	225286	AL41	Cover, PTFE*	1
8	TR301-0432	254493, 260432	AL108	Nozzle holder - ceramic	1
9	TR301-3202	0353202, 900594	AL272	Brush	1
10	TR301-8557	88557	88557	Nozzle - 90 degrees	1
11	TR301-6184	256184	256184	Blow tube	1

*PolyTetraFluoroEthylene is a fluorocarbon-based polymer and is commonly abbreviated PTFE. The Teflon® brand of PTFE is manufactured only by DuPont and is not sold by Hypertherm. Hypertherm purchases other brands of PTFE from various high quality manufacturers.

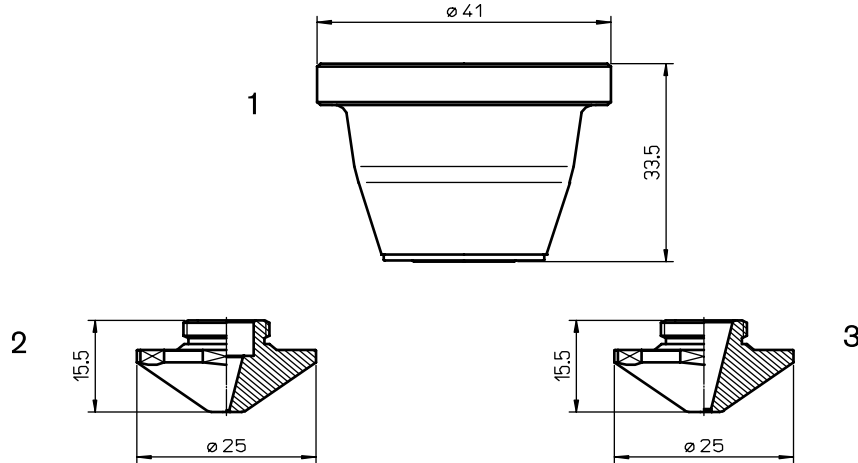

Consumables

	Centricut part number	Reference number	Alternate reference	Description	Pkg qty
1	TR301-9171	1349171	AL405	Nozzle holder – ceramic	1
2	TR407-4858	1324858	L1270	Nozzle – 0.8 mm	1
	TR407-4858X	1324858	L501270	Nozzle – 0.8 mm (10 pack)	10
	TR407-4860	1324860	L1272	Nozzle – 1.0 mm	1
	TR407-4860X	1324860	L501272	Nozzle – 1.0 mm (10 pack)	10
	TR407-4861	1324861	L1273	Nozzle – 1.2 mm	1
	TR407-4861X	1324861	L501273	Nozzle – 1.2 mm (10 pack)	10
	TR407-4863	1324863	L1275	Nozzle – 1.4 mm	1
	TR407-4863X	1324863	L501275	Nozzle – 1.4 mm (10 pack)	10
	TR407-4864	1324864	L1276	Nozzle – 1.7 mm	1
	TR407-4864X	1324864	L501276	Nozzle – 1.7 mm (10 pack)	10
	TR407-4858CPH	1324858	L1270XH	Nozzle – 0.8 mm hard CP	1
	TR407-4858CPHX	1324858	L501270XH	Nozzle – 0.8 mm hard CP (10 pack)	10
	TR407-4860CPH	1324860	L1272XH	Nozzle – 1.0 mm hard CP	1
	TR407-4860CPHX	1324860	L501272XH	Nozzle – 1.0 mm hard CP (10 pack)	10
	TR407-4861CPH	1324861	L1273XH	Nozzle – 1.2 mm hard CP	1
	TR407-4861CPHX	1324861	L501273XH	Nozzle – 1.2 mm hard CP (10 pack)	10
	TR407-4863CPH	1324863	L1275XH	Nozzle – 1.4 mm hard CP	1
	TR407-4863CPHX	1324863	L501275XH	Nozzle – 1.4 mm hard CP (10 pack)	10
	TR407-4864CPH	1324864	L1276XH	Nozzle – 1.7 mm hard CP	1
TR407-4864CPHX	1324864	L501276XH	Nozzle – 1.7 mm hard CP (10 pack)	10	
3	TR407-4865	1324865	L1277	Nozzle – 2.0 mm	1
	TR407-4865X	1324865	L501277	Nozzle – 2.0 mm (10 pack)	10
	TR407-4866	1324866	L1278	Nozzle – 2.3 mm	1
	TR407-4866X	1324866	L501278	Nozzle – 2.3 mm (10 pack)	10
	TR407-4867	1324867	L1279	Nozzle – 2.7 mm	1
	TR407-4867X	1324867	L501279	Nozzle – 2.7 mm (10 pack)	10
	TR407-4865CPH	1324865	L1277XH	Nozzle – 2.0 mm hard CP	1
	TR407-4865CPHX	1324865	L501277XH	Nozzle – 2.0 mm hard CP (10 pack)	10
	TR407-4866CPH	1324866	L1278XH	Nozzle – 2.3 mm hard CP	1
	TR407-4866CPHX	1324866	L501278XH	Nozzle – 2.3 mm hard CP (10 pack)	10
	TR407-4867CPH	1324867	L1279XH	Nozzle – 2.7 mm hard CP	1
	TR407-4867CPHX	1324867	L501279XH	Nozzle – 2.7 mm hard CP (10 pack)	10
		TR407-7264 (not shown) NEW	ZAA-01, 1637264	L1260	Nozzle – Focusing

1

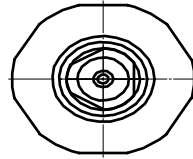
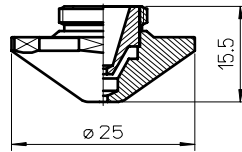

Consumables

Centricut part number	Reference number	Alternate reference	Description	Pkg qty
TR426-1308		L1308	Nozzle - 0.8 mm double	1
TR426-1308X		L501308	Nozzle - 0.8 mm double (10 pack)	10
TR426-1309		L1309	Nozzle - 1.0 mm double	1
TR426-1309X		L501309	Nozzle - 1.0 mm double (10 pack)	10
TR426-1310		L1310	Nozzle - 1.2 mm double	1
TR426-1310X		L501310	Nozzle - 1.2 mm double (10 pack)	10
TR426-1311		L1311	Nozzle - 1.4 mm double	1
TR426-1311X		L501311	Nozzle - 1.4 mm double (10 pack)	10
TR426-1312		L1312	Nozzle - 1.7 mm double	1
TR426-1312X		L501312	Nozzle - 1.7 mm double (10 pack)	10
TR426-1308CPH		L1308XH	Nozzle - 0.8 mm double hard CP	1
TR426-1308CPHX		L501308XH	Nozzle - 0.8 mm double hard CP (10 pack)	10
TR426-1309CPH		L1309XH	Nozzle - 1.0 mm double hard CP	1
TR426-1309CPHX		L501309XH	Nozzle - 1.0 mm double hard CP (10 pack)	10
TR426-1310CPH		L1310XH	Nozzle - 1.2 mm double hard CP	1
TR426-1310CPHX		L501310XH	Nozzle - 1.2 mm double hard CP (10 pack)	10
TR426-1311CPH		L1311XH	Nozzle - 1.4 mm double hard CP	1
TR426-1311CPHX		L501311XH	Nozzle - 1.4 mm double hard CP (10 pack)	10
TR426-1312CPH		L1312XH	Nozzle - 1.7 mm double hard CP	1
TR426-1312CPHX		L501312XH	Nozzle - 1.7 mm double hard CP (10 pack)	10
TR426-1313		L1313	Nozzle - 2.0 mm double	1
TR426-1313X		L501313	Nozzle - 2.0 mm double (10 pack)	10
TR426-1314		L1314	Nozzle - 2.3 mm double	1
TR426-1314X		L501314	Nozzle - 2.3 mm double (10 pack)	10
TR426-1315		L1315	Nozzle - 2.7 mm double	1
TR426-1315X		L501315	Nozzle - 2.7 mm double (10 pack)	10
TR426-1313CPH		L1313XH	Nozzle - 2.0 mm double hard CP	1
TR426-1313CPHX		L501313XH	Nozzle - 2.0 mm double hard CP (10 pack)	10
TR426-1314CPH		L1314XH	Nozzle - 2.3 mm double hard CP	1
TR426-1314CPHX		L501314XH	Nozzle - 2.3 mm double hard CP (10 pack)	10
TR426-1315CPH		L1315XH	Nozzle - 2.7 mm double hard CP	1
TR426-1315CPHX		L501315XH	Nozzle - 2.7 mm double hard CP (10 pack)	10

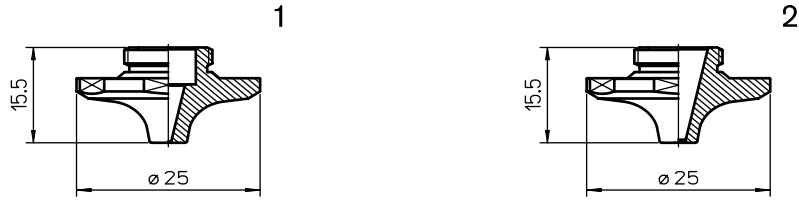

Consumables

	Centricut part number	Reference number	Alternate reference	Description	Pkg qty
1	TR426-3325	1373325	L1501	Nozzle - 1.0 mm	1
	TR426-3325X	1373325	L501501	Nozzle - 1.0 mm (10 pack)	10
	TR426-3326	1373326	L1502	Nozzle - 1.2 mm	1
	TR426-3326X	1373326	L501502	Nozzle - 1.2 mm (10 pack)	10
	TR426-3327	1373327	L1503	Nozzle - 1.4 mm	1
	TR426-3327X	1373327	L501503	Nozzle - 1.4 mm (10 pack)	10
	TR426-3328	1373328	L1504	Nozzle - 1.7 mm	1
	TR426-3328X	1373328	L501504	Nozzle - 1.7 mm (10 pack)	10
2	TR426-3324	1373324	L1500	Nozzle - 0.8 mm	1
	TR426-3324X	1373324	L501500	Nozzle - 0.8 mm (10 pack)	10
	TR426-3329	1373329	L1505	Nozzle - 2.0 mm	1
	TR426-3329X	1373329	L501505	Nozzle - 2.0 mm (10 pack)	10
	TR426-3330	1373330	L1506	Nozzle - 2.3 mm	1
	TR426-3330X	1373330	L501506	Nozzle - 2.3 mm (10 pack)	10
	TR426-3331	1373331	L1507	Nozzle - 2.7 mm	1
	TR426-3331X	1373331	L501507	Nozzle - 2.7 mm (10 pack)	10

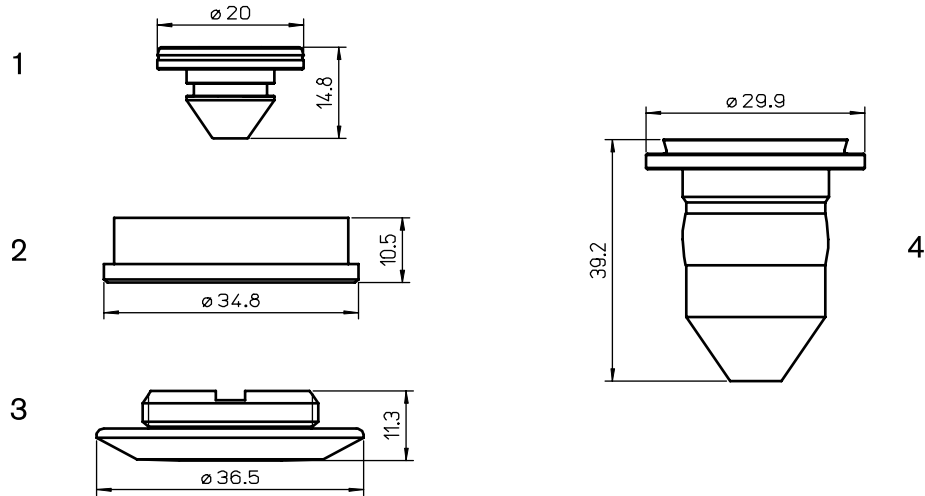

Consumables

	Centricut part number	Reference number	Alternate reference	Description	Pkg qty
1	TR303-2952	202952	L5	Nozzle - 0.8 mm HP	1
	TR303-0969	218969	L34	Nozzle - 1.0 mm HP	1
	TR303-9402	209402	L35	Nozzle - 1.4 mm HP	1
	TR303-7953	217953	L36	Nozzle - 1.7 mm HP	1
2	TR303-0001		AL8	Stylus foot	1
3	TR303-6086	216086	AL7	Stylus foot	1
4	TR304-0653-08	60653	L217	Nozzle - 0.8 mm	1
	TR304-0653-3	60653	L218	Nozzle - 1.0 mm	1
	TR304-0653-14	60653	L219	Nozzle - 1.4 mm	1
Filters - not shown					
	TR301-2380	92380	FT1	Filter DX	1
	TR301-2381	92381	FT2	Filter BX	1
	TR301-2379	92379	FT3	Filter CI	1
	TR301-3676	123676 - U0310 VF	FT4	Filter	1
	TR301-3675	123675 - U0310 SMA	FT5	Filter	1
	TR301-3674	123674 - U0310 CA	FT6	Filter	1
	TR301-6152	146152	CP10	Filter	1
	TR301-5942 NEW	0115942		Filter	1

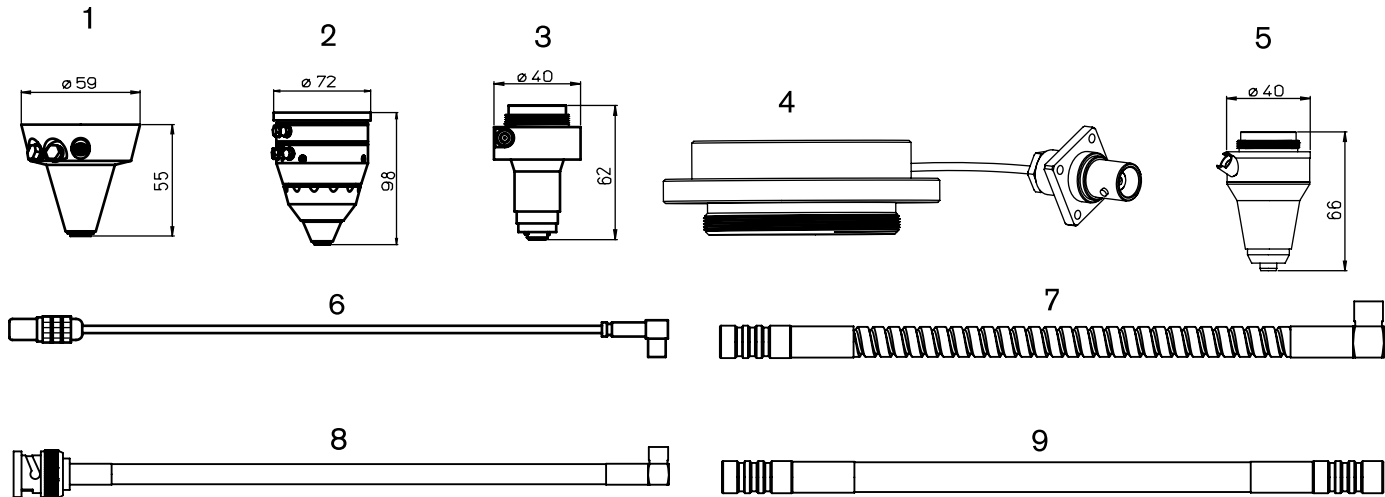

Consumables

	Centricut part number	Reference number	Alternate reference	Description	Pkg qty
1	PT999-YH27	562313		Sensor repair YH27	1
2	PT999-YR30	YR-30		Sensor repair YR30	1
3	TR999-3963	913963		Sensor repair 913963 (Slim)	1
4	TR999-8351	938351	9392-850	Sensor repair - Trumatic	1
5	PT999-KN	280549		Sensor repair KN	1
6	TR301-1086	0351086, P0492-001-00000	351086	Sensor cable	1
7	TR301-9983	359983		Sensor cable - armored 190 mm (7.5")	1
8	TR301-7833	227833		Sensor cable - armored 432 mm (17")	1
9	TR301-0930	280930		Sensor cable - armored 152 mm (6")	1

Sensor repairs available in select regions only.

Optics

Centricut part number	Reference number	Type	Diameter	Focal length	Edge thickness
Lenses					
TR300-6104	346104	MEN	1.5"	3.75"	.290"
TR300-8114	88114	MEN	1.5"	5.0"	.290"
TR300-8398	58398	MEN	1.5"	5.0"	.100"
TR300-0002	706491	MEN	1.5"	5.0"	.157"
TR300-0130	NEW 400130LMA	MEN	1.575"	5.118"	.295 CUT
TR300-7517	97517	MEN	1.5"	7.5"	.290"
TR300-8123	581123	MEN	1.5"	6.102"	.295"
TR300-1972	141972	MEN	1.5"	9.0"	.290"
TR300-0163	350163	MEN	1.5"	10.0"	.290"
TR300-6477	726477	MEN	1.5"	10.0"	.354"
TR300-0250	NEW 0380115, 400250LMA	MEN	1.575"	9.842"	.295 CUT
Ultra low absorption lenses					
TR300-8114MP5	88114	MEN	1.5"	5.0"	.290"
TR300-7517MP5	97517	MEN	1.5"	7.5"	.290"
Windows					
TR301-4028	NEW 4304028	ZNSE	1.97"	.398"	

Optics

Centricut part number	Reference	Typr	Material	Diameter	Edge thickness
Phase shift mirrors					
TR300-5460	85460	PS	CU	2.0"	.374"
TR300-1559	71559	PS	SI	2.0"	.200"
TR300-3349	133349	PS	SI	2.0"	.400"
TR300-9917	969917	PS	SI	2.0"	.400"
TR300-9880	129880	PS	SI	2.67"	.800"

Centricut part number	Reference number	Type	Material	Diameter	Edge thickness	S1
TR300-8621 NEW	998621	MMR	CU	1.969"	1.920"	WC
TR300-6066	96066	TRZ	SI	1.5"	.375"	
TR300-2772	182772	TRZ	SI	1.5"	.375"	SEG
TR300-4958	364958	TRZ	SI	1.5"	.375"	PO-PLM
TR300-0681	100681	TRZ	SI	2.00"	.400"	
TR300-1571	851571	TRZ	SI	2.0"	.400"	
TR300-9881	129881	TRZ	SI	2.67"	.800"	
TR300-2070	352070	TRZ	SI	2.67"	.800"	
TR300-0689	920689	TRZ	CU	2.67"	1.34"	WC

Centricut part number	Reference number	Material	Diameter	Edge thickness	S1
Output couplers					
TR300-5725	895725	ZNSE	1.0"	.236"	
TR300-5092	13350	ZNSE	1.0"	.236"	PO/PO
TR300-9994	319994	ZNSE	1.0"	.236"	50%R
TR300-8252	638252	ZNSE	1.0"	.236"	60% PO/AR
TR300-5774	285774	ZNSE	1.0"	.236"	6.87MCC/40%
TR300-9192	459192	ZNSE	1.0"	.236"	18MCC/50%
TR300-4651	185651	ZNSE	1.5"	.120"	

Centricut part number	Reference number	Material	Diameter	Edge thickness	S1	Reflectivity
Rear mirrors						
TR300-8316	128316	GAAS	1.0"	.236"	20MCC	99.5%
TR300-6714	656714	GA	1.0"	.236"		99.7%
TR300-6378	586378	GA	1.0"	.236"	20MCC	99.7%
TR300-6634	536364	GA	1.0"	.236"	30MCC	99.7%

Optics care

Centricut part number	Reference number	Description	Pkg qty
TR300-6452	N/A	Lens cleaning paper, Tiffen – 50 piece	1
AM313-SC50 NEW	SC50	Lens cleaning paper, Tresor – 50 piece	1
TR300-1115		Lens cleaning pre-cut cotton – 80 piece	1
TR300-SC20		Cotton swab – 20 piece	1
TR300-1010	AL1010	Dropper, lens cleaning fluid	1
TR300-255	AL255	Loupe, magnifying	1
TR300-271	AL271	Base, lens maintenance	1
TR300-7388	787388	Mirror polish (250 ml)	1
AM313-1260 NEW	351260-009	Lens Polarizing Filter – 1.5"	1
AM313-1280 NEW	351280-009	Lens Polarizing Filter – 2.0"	1

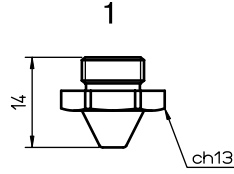

Consumables

	Centricut part number	Reference number	Alternate reference	Description	Pkg qty
1	VA402-0001		L48	Nozzle - 0.9 mm	1
	VA402-0002		L761	Nozzle - 1.5 mm	1

Optics care

Centricut part number	Reference number	Description	Pkg qty
TR300-6452	N/A	Lens cleaning paper, Tiffen - 50 piece	1
AM313-SC50 NEW	SC50	Lens cleaning paper, Tresor - 50 piece	1
TR300-1115		Lens cleaning pre-cut cotton - 80 piece	1
TR300-SC20		Cotton swab - 20 piece	1
TR300-1010	AL1010	Dropper, lens cleaning fluid	1
TR300-255	AL255	Loupe, magnifying	1
TR300-271	AL271	Base, lens maintenance	1
TR300-7388	787388	Mirror polish (250 ml)	1
AM313-1260 NEW	351260-009	Lens Polarizing Filter - 1.5"	1
AM313-1280 NEW	351280-009	Lens Polarizing Filter - 2.0"	1



Centricut also manufactures consumables for most major mechanized plasma systems including ESAB, Kaliburn and Kjellberg



To learn more about Centricut's line of plasma consumables, visit: www.hypertherm.com/centricut

Centricut products deliver performance superior to the OEM, along with Hypertherm quality at a competitive price.

Hypertherm[®]
Cut with confidence[®]

PLASMA | LASER | WATER JET | AUTOMATION | SOFTWARE | CONSUMABLES

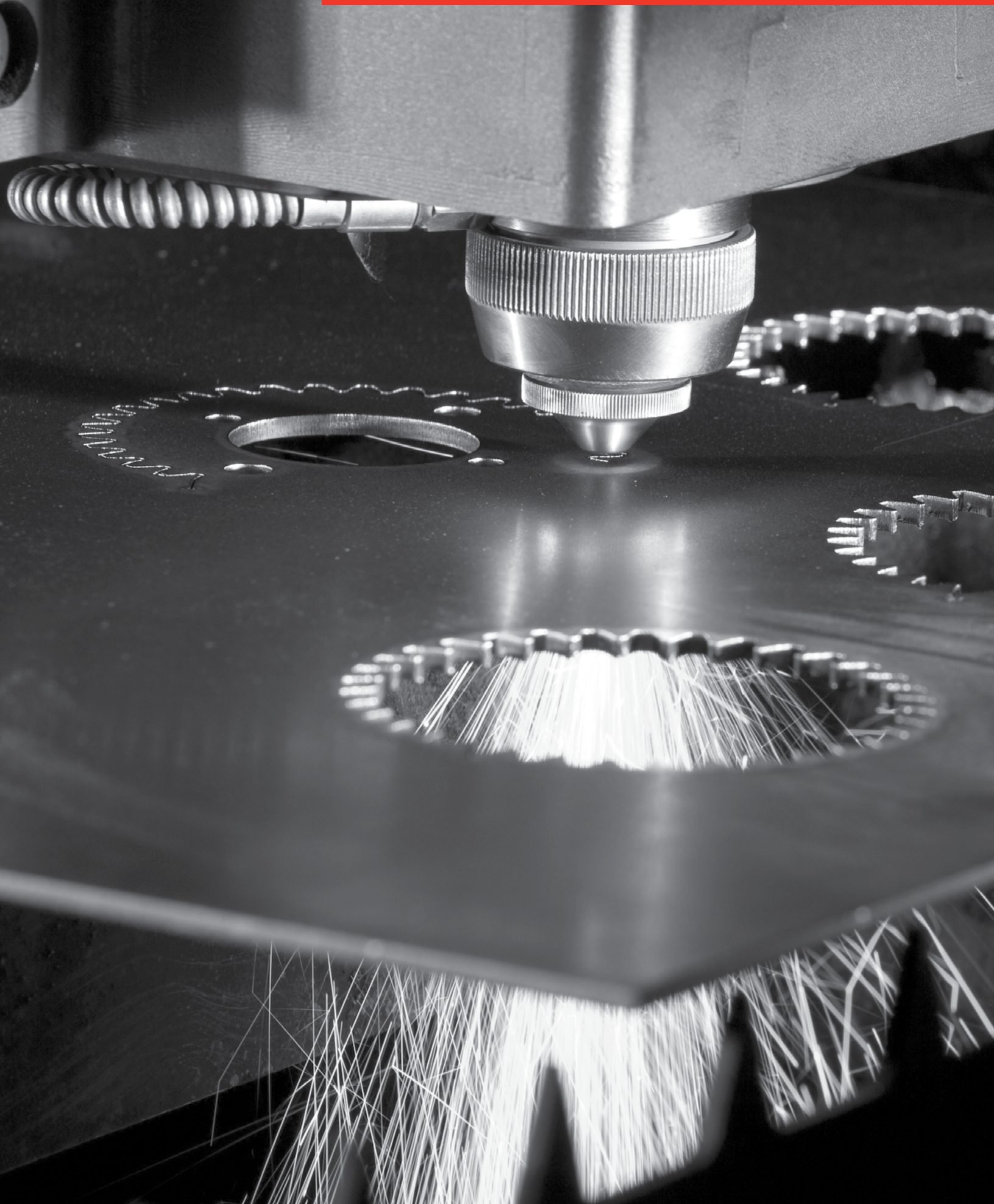

Providing options for sensor cone needs



Purchase new or refurbish your old sensor cone - either way, will save money and give the same quality as the OEM offering

NEW sensor cones

- For Amada, Mazak (Precitec), and Mitsubishi (Precitec) CO₂ laser cutting heads
- Delivering the same OEM performance at a value price
- Engineered and manufactured to Hypertherm's high quality standards

Sensor cone repair*

- For most major OEMs including Precitec, Trumpf, Amada, Mazak, Mitsubishi and Finn-Power laser systems at a fraction of the cost of new
- Fitted with new internal components and restored to factory specifications
- Backed by Centricut's limited one year warranty and 100% satisfaction guarantee

*Sensor cone repairs are not available in all regions

New sensor cones

Centricut part number	OEM	Reference number	Description
AM343-9107	Amada	ECO cone	Sensor cone - ECO
AM343-1690	Amada	71341690	Sensor cone - HS98
PT347-3323	Mazak	567123323A	Nozzle body HNPZ
PT347-0011	Mitsubishi	P0354-110-00002	Sensor cone HNZ
PT347-8001	Precitec	280010	Sensor cone 2.5Z/J
PT347-0522	Precitec	P0599-520-00002	Sensor cone LRC

Refurbished sensor cones

Centricut part number	OEM	Reference number	Description
AM999-HS95	Amada	71341621	Sensor repair HS95 (86 mm x 69 mm)
AM999-HS95M	Amada	71360091	Sensor repair HS95 mini (70 mm x 69 mm)
AM999-ECO	Amada	71399107	Sensor repair ECO
AM999-HS98	Amada	71341690	Sensor repair HS98
AM999-L3015C	Amada	71374509	Sensor repair L3015C
AM999-HPX	Amada		Sensor repair HPX
AM999-HPL	Amada	74810277	Sensor repair HP-L (red)
AM999-WACS	Amada	71502035	Sensor repair HP-X WACS
MZ999-HNPZ (HNP)	Mazak	567123323A1	Sensor repair HNP
PT999-HNZ	Mazak	56743300500	Sensor repair HNZ
MB999-429A	Mitsubishi	W429A	Sensor repair W429A
PT999-25ZJ	Mitsubishi	P0361-203-00001	Sensor repair 25ZJ
MB999-239	Mitsubishi	W239	Sensor repair W239
MB999-SE	Mitsubishi	P0594-820-00001	Sensor repair SE
PT999-DXN	Precitec	P0589-800-00001	Sensor repair DXN
PT999-YH27	Precitec	P0589-800-00001	Sensor repair YH27
PT999-YR30	Precitec	YR-30	Sensor repair YR-30
PT999-DZ	Precitec	281145	Sensor repair DZ
PT999-KN	Precitec	280549	Sensor repair KN
PT420-0125	Precitec		Sensor repair 25ZJ
PT999-HP2	Precitec	281672	Sensor repair HP/HP2Z

* Not available in all regions. Sensor cone repair is available for most sensor cones. Only a representation is listed above. For more information contact us at CTLaser@hypertherm.com

Armored sensor cables

Centricut armored sensor cables

Get the rugged toughness you need with Centricut armored sensor cables. Weaker designed cables require frequent changes, downtime and loss of production.

- Robust design
- Reinforced collar for longer life
- Extreme temperature rating (900°–1200° F)
- Guaranteed to outlast standard OEM cables

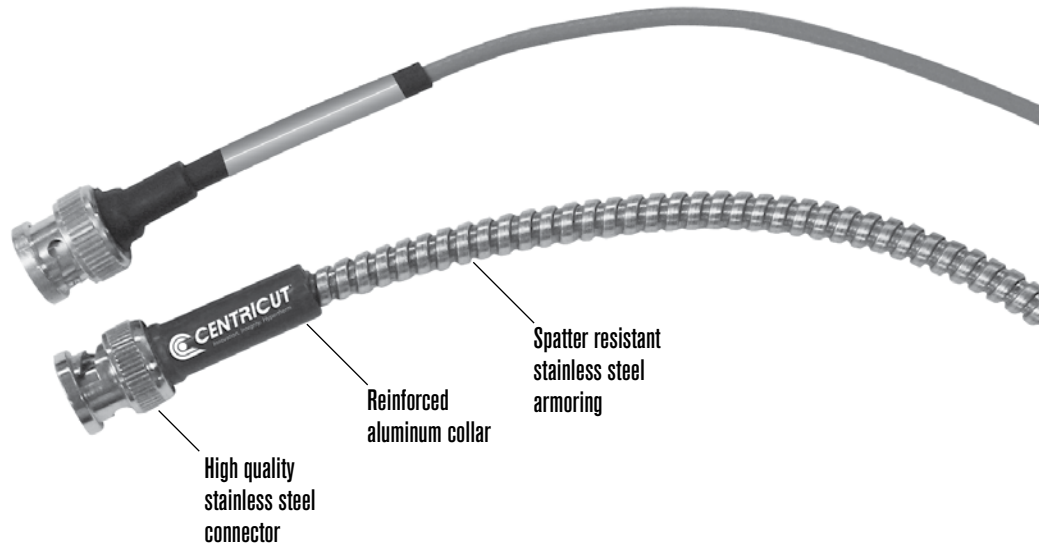

Armored sensor cables

Centricut part number	OEM	Reference number	Description
AM308-8965A	Amada	71398965	Sensor cable - armored 305 mm (premium)
AM313-1901A	Amada	71341630	Sensor cable - HS-5 305 mm (premium)
AM313-9851A	Amada	71369851	Sensor cable - armored 203 mm (premium)
CN306-0654A	Cincinnati	909654, 922686	Sensor cable - armored 114 mm (4.5")
CN306-0951A	Cincinnati	842951	Sensor cable - armored 140 mm (5.5")
MZ335-630A	Mazak		Sensor cable - armored 630 mm (25")
MZ335-1980A	Mazak	46683301980	Sensor cable - armored 280 mm (11")
MZ335-0111A	Mazak	4674330111	Sensor cable - armored 280 mm (11")
MZ335-1980	Mazak	46683301980	Sensor cable - armored 280 mm (11")
MZ335-0181A	Mazak	46743300181	Sensor cable - armored 317.5 mm (12.5")
MZ335-1330A	Mazak	46683301330	Sensor cable - armored 305 mm (12")
NT426-8677	NTC	4R028677-001	Sensor cable - armored 508 mm (20")
PT347-0101A	Precitec	P0360-100-00500	Sensor cable - armored 500 mm (20")
PT347-0181	Precitec	46743300181	Sensor cable 305 mm - armored (12")
PT347-1386	Precitec	281386, P0360-155-00500	Sensor cable - armored
TR301-7833	Trumpf	0227833	Sensor cable - armored 432 mm (17")
TR301-9983	Trumpf	359983, 342474	Sensor cable - armored 190 mm (7.5")
TR301-0930	Trumpf	280930	Sensor cable - armored 152 mm (6")
PT347-0250	Trumpf	342475	Sensor cable - armored 250 mm (9.85")

Lens cleaning tips

You will need:

- Scientific-grade acetone
- Air bulb
- Lens tissue
- Plastic lens holder
- Cotton swabs
- Eye dropper
- Rubber gloves

Step #1

Using rubber gloves, place lens in lens holder. Use air bulb to remove all loose contaminants from the optic. If the contaminants are still visible please proceed to step #2.

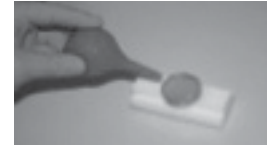

Step #2

Place a new piece of lens tissue over the optic, completely covering the optic



Step #3

Fill eye dropper 1/2 full with acetone.

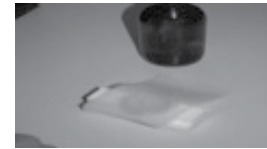

Step #4

Drip acetone on the center of the optic until it is saturated to the outside diameter.

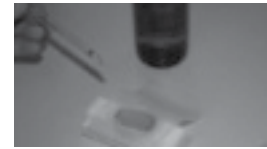

Step #5

Pull the lens tissue slowly across the optic. Going too fast will leave acetone residue behind. Acetone will evaporate when the tissue is dragged across the lens at the correct speed.



Step #6

If top side of lens is contaminated, repeat steps 1-5.



Step #7

Place clean optic in the machine quickly to avoid getting airborne particles on the clean optic.

If spots, pits, or scratches are still noticeable, the optic may need to be replaced

CO₂ laser optics

Optics key

Lens	
PFL	Pre-focus
MEN	Meniscus
PLX	Plano-convex
MTD	Mounted
Not MTD	Not mounted
LA	Low absorption
PO	Plano
ULA	Ultra low absorption

Mirrors	
CU	Copper
GAAS	Gallium arsenide
SI	Silicon
GE	Germanium
ZNSE	Zinc-selenide
PS	Phase shift
MMR	Maximum metal reflector
ATFR	Absorbing thin film reflector
TRZ	Total reflector – zero phase shift
ZPS	Zero phase shift
OC	Output coupler
RM	Rear mirror
COL-I	Collimator input
COL-O	Collimator output
AO	Adaptive optic
MO	Molybdenum
UC	Uncoated
M CX	Convex
M CC	Concave

Measurements	
DIA	Diameter
FL	Focal length
ET	Edge thickness

How to handle optics

Follow these easy steps, when cleaning or changing your optic, to help maximize the life and performance of your lens

- Avoid touching coated surfaces of the lens and hold the optic by its sides
- Wear powder-free finger cots or latex gloves when handling
- Do not use any tools or sharp objects when handling the optic or when removing it from its packaging
- Ensure the work surface is clean and free of oils, grease and dirt
- Do not place the optic on hard surfaces as they scratch easily
- Once the optic has been unpacked, carefully place it on the lens tissue in which it was originally wrapped

Optics disposal

It is important to dispose of used laser optics at a licensed industrial waste facility which is in compliance with all local, state, and federal regulations. If you don't have access to a licensed industrial waste facility, and purchased your laser optics through Centricut, you may return them to Centricut for proper disposal. This service is only available to Centricut customers.

All optics returned to Centricut must:

- Include return authorization and invoice numbers
- Be sealed in a plastic bag to minimize any hazards
- Remove excess ZnSe powder prior to sealing

*Acceptance of goods will be refused if not packaged correctly or if the return authorization number isn't included



Technical support

Our technical service team can answer questions about any laser cutting system. Whether it's a question about a part, a system, or for guidance on how to optimize performance, our experts can help.

- We stand behind our products with industry-leading technical expertise
- OEM trained technicians on staff with over 25 years experience
- Free application support for all laser OEMs



Contact us at: CTlaser@hypertherm.com

Broadest product line in the industry

Trumpf



Bystronic



Amada



Mazak



Mitsubishi



Precitec



Prima



NTC



Tanaka



For more information on Centricut laser products,
visit www.hypertherm.com/centricut/laser

Hypertherm and Centricut are trademarks of Hypertherm Inc., and may be registered in the United States and/or other countries. All other trademarks are the property of their respective owners.

One of Hypertherm's long-standing core values is a focus on minimizing our impact on the environment. Doing so is critical to our, and our customers' success. We are always striving to become better environmental stewards; it is a process we care deeply about.

© 9/2013 Hypertherm Inc. Revision 4



Hypertherm[®]
Cut with confidence[®]

