

Hypertherm[®]

***Centricut[®] plasma torches
and consumables***



PAGE	OEM	TORCH	SYSTEM
2	CENTRICUT®	SE200®	MAX200®
3		SE2000®	HT2000®
4	AMADA®	IC200®	IC200
5	ESAB®	PT-31/PT-31XL	PCM-VPi, PCM-SMi, PCM-500i, PCM-625i, PCM-50A, PCM-875 and PCM-1125
6		PT-17A/PT-17AM	PCM-70, PCM-100 and PCM-150
7		PT-121/PT-121M	PCM-150
8		PT-20AM	PCM-100, PCM-875, PCM-1125 and ESP-100i
9		PT-24	Precision Plasmarc
10		PT-15/PT-15XL Nitrogen	PCM-8, ESP-300, ESP-400, ESP-600 and ESP-1000
11		PT-15XL Oxygen	PCM-8, ESP-300, ESP-400, ESP-600 and ESP-1000
12		PT-15/PT-15XL Nozzle components	PCM-8, ESP-300, ESP-400, ESP-600 and ESP-1000
13		PT-19XL	ESP-200/300/400/600C/1000, PCM-150/1500/8XL
13		PT-19XL+S	ESP-200/300/400/600C/1000, PCM-150/1500/8XL
14		PT-19XLS	ESP-200/300/400/600C/1000, PCM-150/1500/8XL
15		PT-600	ESP-200/300/400/600C/1000, PCM-150/1500/8XL
16		XP3 for PT600 and PT-19XLS	ESP-200/300/400/600C/1000, PCM-150/1500/8XL
New! 17		PT-36	ESP-200/300/400/600C/1000, PCM-150/1500/8XL
18	KALIBURN®	FineLine™200	FineLine200PC and 150PC
19		ProLine and FineLine	ProLine 2150, 2200, 2260, FineLine 150, 200, 260
20		SR-45i	SR-45i®
20		SR-45i Retrofit	SR-45i
21	KJELLBERG®	PB-S70/75	FineFocus 800®, PA-S70, PA-S75
21		PB-S77	FineFocus 800®, 900
22		PerCut 101®	HiFocus 100®
23		PerCut 160/170/PerCut 370.1	HiFocus 130/160i, HiFocus 280i/360i/440i
New! 24		PB-S80 and PerCut 370.2	FineFocus 800 Plus, HiFocus 280i/360i/440i
New! 25	KOIKE®	Super-400 Plus	Super-400 Plus
26	KOMATSU®	RASOR 40 AMP	RASOR® 40 AMP
27		RASOR 90/120 AMP	RASOR 90/120 AMP
28		RASOR 300 AMP	RASOR 300 AMP
29	LINCOLN®	PRO-CUT 40 and 60	PRO-CUT® 40 and 60
30	THERMAL	PCH-20 and PCH/M-30	DYNAPAK 110®, PAK® 2XT™ and PAK3®
31	DYNAMICS®	PCH/M-10/25	PAK MASTER® 25, ECONO PAK 25, DRAG GUN
31		PCH/M-26/28/35/38	STAK PAK® 35, PAK MASTER® 50, 38XL, ECONO PAK® 50
32		PCH/M-50	PAK® 5
32		PCH/M-51	PAK 3XR™, 5XR™, 5XT™, 6XR™, 625XR™, 750XR™, DYNAPAK 4Xi, 6Xi
33		PCH/M-52	PAK 5XR™, 6XR™, 7XR™, 8XR™, 10XR™, 625XR™, 750XR™, 1000XR™, 1250XR™
34		PCH/M-53	PAK MASTER 100
35		PCH/M-70	STAK PAK
36		PCH/M-4A, 4B, 4BT	PAK 22,10, 5
37		PCH/M-6B	PAK 44, 45
38		PCH/M-100	PAK 10XR™
39		PCH/M-140	STAK PAK
40		PCH/M-150	PAK 15XC, MERLIN®
41		MAXIMIZER 300	MERLIN 3000/6000/6000GST
42		M-200	TA500, 1000
43	WHITNEY®	OW250	OW250®
44		IC300	IC300®
45		TRUECUT®	TRUECUT
46	WIEDEMANN®	IC100®	WIEDEMANN IC100®

Consumables

Centricut part number	Reference number	Description	Pkg qty
1 C61-280	N/A	Shield, ported, dry/underwater*, 200 amp	1
2 C61-281	N/A	Shield, ported, dry/underwater*, 100 amp	1
C61-264	N/A	Shield ring, 1 piece, 40 amp	1
3 C61-270	N/A	Retaining ring, heavy duty	1
4 C92-230	N/A	Retaining cap	1
C61-273	N/A	Retaining ring, HD with IHS tab	1
5 C61-207	N/A	Nozzle, Air/N ₂ /ArH ₂ , 200 amp	1
C61-263	N/A	Nozzle, Air, 40 amp	1
C61-300	N/A	Nozzle, O ₂ , 100 amp	1
C61-232	N/A	Nozzle, Air, 100 amp	1
C61-288	N/A	Nozzle, O ₂ , 200 amp	1
6 C61-227	N/A	Gas guide, Air/N ₂ /ArH ₂	1
C61-304	N/A	Gas guide, O ₂ , 100 amp	1
C61-289	N/A	Gas guide, O ₂ , 200 amp	1
C61-295	N/A	Gas guide, Air/N ₂ /ArH ₂ /CCW	1
7 C61-265	N/A	Electrode, SuperPierce, Air	1
C61-241	N/A	Electrode, N ₂ , ArH ₂	1
C61-287	N/A	Electrode, O ₂ , 200 amp	1

* Use with C61-270

Maintenance items

Centricut part number	Reference number	Description	Pkg qty
C61-253	N/A	Gas guide cleaning tool	1
8 C92-228	N/A	Water tube	1
C92-229	N/A	Water tube wrench	1
C61-099	N/A	Wrench – electrode/nozzle	1
9 C61-213	N/A	Torch body, with water tube and wrench	1
C61-STR	N/A	Air starter kit, (see below)	1
C61-OXY200	N/A	Oxy starter kit	1
C66-023	N/A	Torch body o-ring	5
C27-134	N/A	Gas guide o-ring	5
027055	N/A	Lubricant .25 oz. (7 ml) tube	1

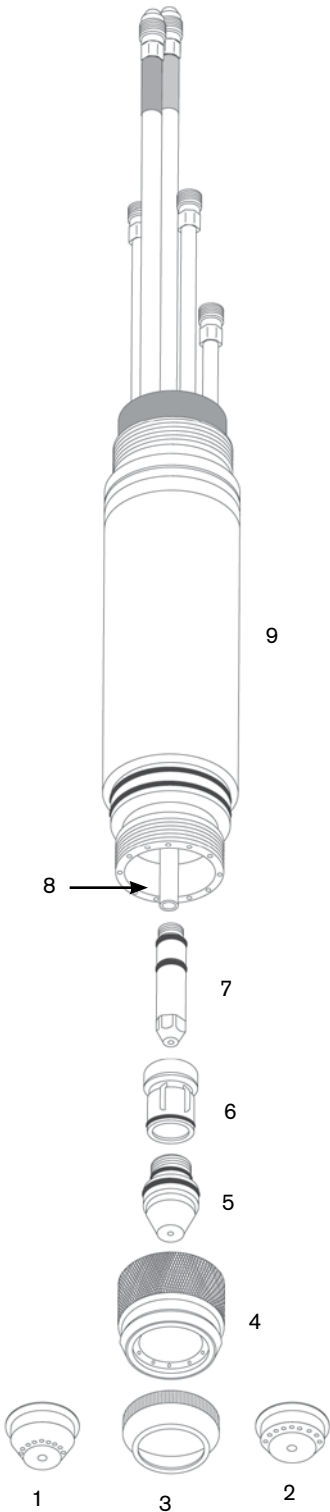

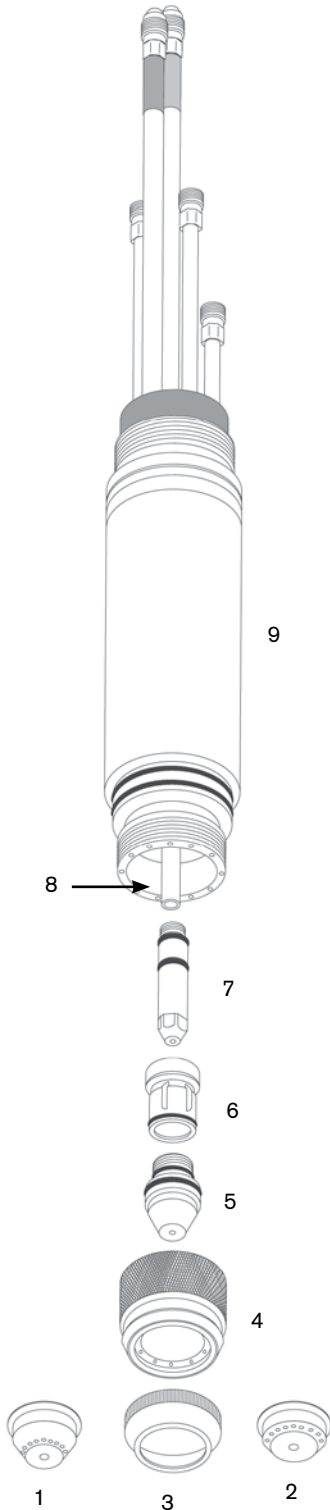

Consumables

Centricut part number	Reference number	Description	Pkg qty
1 C61-280	N/A	Shield, ported, dry/underwater*, 200 amp	1
2 C61-281	N/A	Shield, ported, dry/underwater*, 100 amp	1
C61-264	N/A	Shield ring, 1 piece, 40 amp	1
3 C61-270	N/A	Retaining ring, heavy duty	1
4 C92-230	N/A	Retaining cap	1
C61-273	N/A	Retaining ring, HD with IHS tab	1
5 C61-207	N/A	Nozzle, Air/N ₂ /ArH ₂ , 200 amp	1
C61-263	N/A	Nozzle, Air, 40 amp	1
C61-300	N/A	Nozzle, O ₂ , 100 amp	1
C61-232	N/A	Nozzle, Air, 100 amp	1
C61-288	N/A	Nozzle, O ₂ , 200 amp	1
6 C61-227	N/A	Gas guide, Air/N ₂ /ArH ₂	1
C61-301	N/A	Gas guide, O ₂ , 100 amp	1
C61-298	N/A	Gas guide, O ₂ , 200 amp	1
C61-295	N/A	Gas guide, Air/N ₂ /ArH ₂ /CCW	1
7 C61-265	N/A	Electrode, Air, 200 amp	1
C61-241	N/A	Electrode, N ₂ , ArH ₂	1
C61-287	N/A	Electrode, O ₂ , 200 amp	1

* Use with C61-270

Maintenance items

Centricut part number	Reference number	Description	Pkg qty
8 C92-228	N/A	Water tube	1
C92-229	N/A	Water tube wrench	1
C61-099	N/A	Wrench – electrode/nozzle	1
9 C61-213	N/A	Torch body, with water tube and wrench	1
C61-STR	N/A	Air starter kit, (see below)	1
C61-OXY2000	N/A	Oxy starter kit	1
C66-023	N/A	Torch body o-ring	5
C27-134	N/A	Gas guide o-ring	5
C61-253	N/A	Gas guide cleaning tool	1
027055	N/A	Lubricant .25 oz. (7 ml) tube	1

* Centricut part features a unique design that differs from the OEM design.

Consumables

Centricut part number	Reference number	Description	Pkg qty
1 C14-332	74172324	Nose piece	1
2 C14-330	74172325	Nozzle, Air, .063, 150 amp	5
C14-331-S	648-331	Nozzle, Air, .098	5
C14-731	N/A	Nozzle, Air, .110	5
3 C14-328	N/A	Electrode, Air, 150 amp	5
C14-927	74172326	Electrode, without o-ring, Air, 250 amp	5
C14-327	74172326	Electrode, with o-ring, Air, 250 amp	5

Maintenance items

Centricut part number	Reference number	Description	Pkg qty
4 C14-794	74172327	Circulating tube, water tube	1
5 C14-280	74172301	Nozzle holder	1
6 C14-282	74172303	Gasket spacers	2
7 C14-281	74172302	Gas guide ring	1
8 C14-286	74172307	Lower gasket	5
9 C14-959	74172308	Insulating spacer	1
10 C14-288	74172309	Cathode holder pkg, middle gasket	5
11 C14-285	74172306	Hole guides	5
12 C14-960	74172310	Manifold	1
C14-283	74172304	O-ring seal	5
C14-284	74172305	O-ring	5
C14-010	N/A	O-ring	5
C14-793	74172311	O-ring, rear manifold	4
13 C14-964	74172314	Upper body	1
C14-866	649-966	Torch tube cover	1
14 C14-961	74172328	Head cover assembly	1
C14-963	74172313	High frequency pin	1
C14-962	74172312	High frequency socket	1
C14-765	649-765	One touch torch	1
15 C14-118*	N/A	Lower torch body assembly (includes items 4 – 12)	1
027055	N/A	Lubricant .25 oz. (7 ml) tube	1

* Centricut part features a unique Hypertherm design that differs from the OEM design.

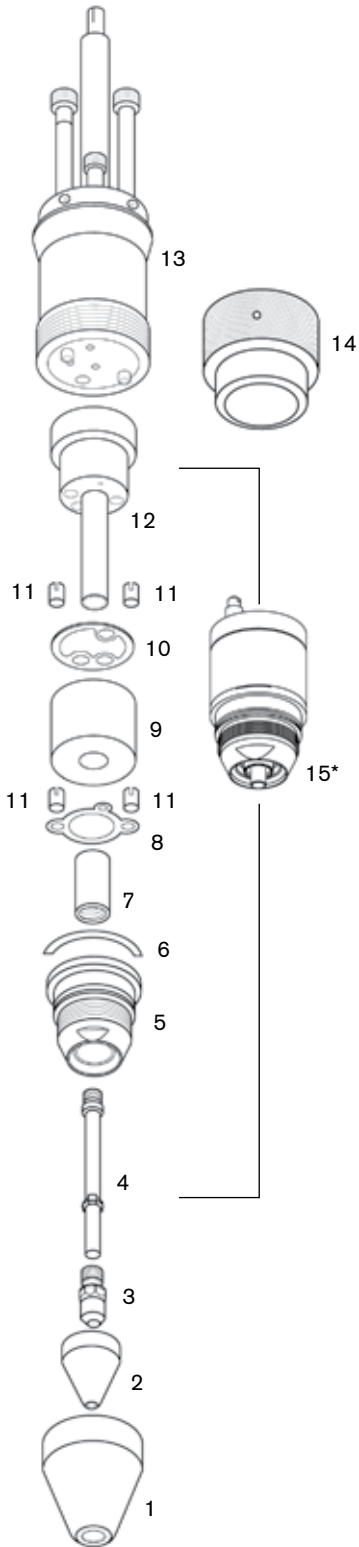

OEM ESAB®

System PCM®-VPi, PCM-SMi, PCM-500i, PCM-625i, PCM-50A, PCM-875 and PCM-1125

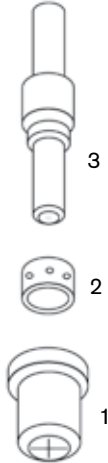

Consumables

Centricut part number	Reference number	Description	Pkg qty
1 C31-682	19682	Tip, XL, 30 amp	10
C31-866	18866	Tip, 30 amp	5
C31-079	20079	Tip, XL, 50 amp	5
L31-820	18820	Tip, 50 amp	5
C31-008	21008	Tip, extended, 40 amp	10
C31-861	20861	Tip, extended, 50 amp	10
2 C31-463	20463	Swirl baffle, XL, 6 holes	1
C31-785	18785	Swirl baffle, 4 holes	1
3 C31-683	19683	Electrode, XL	5
C31-205	18205	Electrode	2
C31-862	20862	Electrode, extended	10
L31-679	19679	Seat	1
L31-282	20282	Heat shield, XL	1

Maintenance items

Centricut part number	Reference number	Description	Pkg qty
L31-072	20072	PT-31XL torch body, 75°	1
L31-790	950790	O-ring	5
027055	N/A	Lubricant .25 oz. (7 ml) tube	1

OEM ESAB®

System PCM®-70, PCM-100 and PCM-150

Consumables

Centricut part number	Reference number	Description	Pkg qty
L11-498	19498	Shroud cap	1
L11-502	19502	Shroud	1
L11-989	19989	Shield guard, drag	1
L11-990	19990	Shield guard	1
1 C11-124	19124	Heat shield	1
L11-747	20747	Heat shield, H.D.	1
2 C11-914	19914	Tip, .037, 30 amp	5
C11-915	19915	Tip, .046, 40 amp	5
C11-916	19916	Tip, .052, 60 amp	5
C11-917	19917	Tip, .057, 80 amp	5
C11-056	20056	Tip, .067, 100 amp	5
L11-426	20426	Tip, gouging, 70 amp	5
L11-427	20427	Tip, gouging, 100 amp	5
3 C11-918	19918	Electrode	5
4 C11-114	19114	Baffle tube	1
5 C11-053	20053	Electrode stem	1

Maintenance items

Centricut part number	Reference number	Description	Pkg qty
6 L11-010	20010	PT-17/17A machine torch body, 180°	1
L11-008	20008	PT-17/17A torch body, 75°	1
027055	N/A	Lubricant .25 oz. (7 ml) tube	1

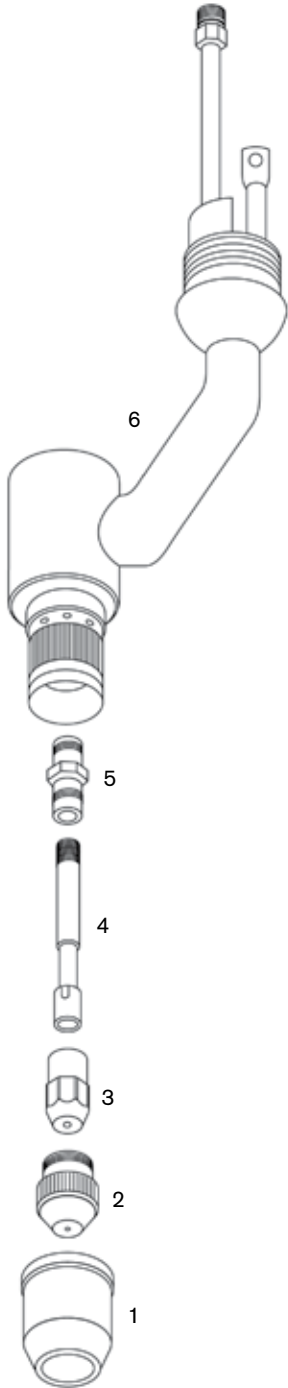

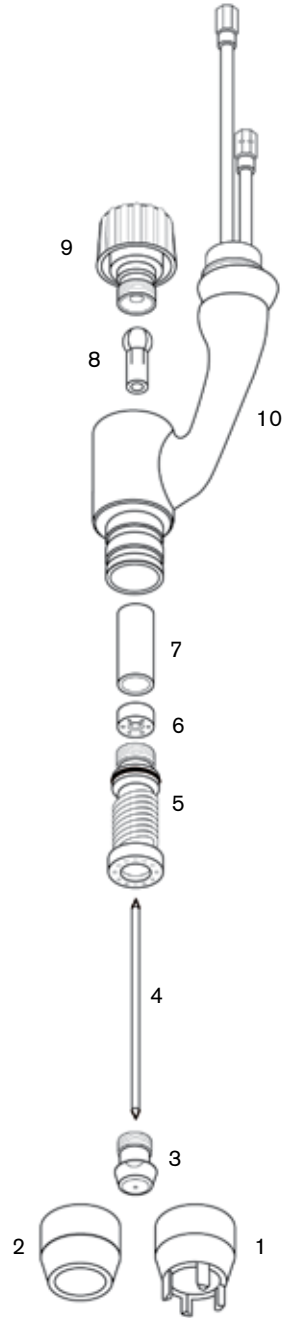

Consumables

Centricut part number	Reference number	Description	Pkg qty
1 L12-620	999620	Heat shield, drag, 50 amp	1
L12-419	18419	Heat shield, drag, 120 amp	1
2 C12-261	999261	Heat shield, machine	5
3 L12-184	17184	Tip, .032	5
C12-119	17119	Tip, .047	10
C12-263	999263	Tip, .055	10
C12-264	999264	Tip, .063	10
4 C12-328	2075328	Electrode	5
5 C12-260	999260	Front body insert with o-ring	1
L12-690	19690	High current body insert with o-ring	1
6 L12-540	19540	Baffle	1
L12-691	19691	High current baffle	1
7 L12-586	999586	Spacer	5
C12-262	999262	Gasket	5

Maintenance items

Centricut part number	Reference number	Description	Pkg qty
8 L12-259	999259	Collet, brass	1
9 L12-257	999257	Torch cap	1
L12-266	999266	Center-adjust tool	1
C12-092	994092	O-ring	5
10 L12-270	999270	PT-121 machine torch	1
027055	N/A	Lubricant .25 oz. (7 ml) tube	1

OEM ESAB[®]

System PCM[®]-100, PCM-875, PCM-1125 and ESP-100i

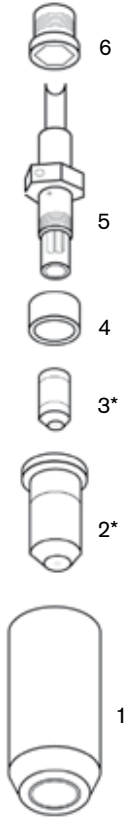

Consumables

Centricut part number	Reference number	Description	Pkg qty
1 L39-447	21447	Heat shield, 50 amp	1
L39-326	21326	Heat shield, 70 – 100 amp	1
2 C39-330*	21330	Nozzle, 50 amp	5
C39-329*	21329	Nozzle, 70 amp	5
C39-328*	21328	Nozzle, 100 amp	5
3 C39-150*	21150	Electrode	5
4 L39-373	21373	Insulator	1
L39-374	21374	Baffle tube	1
5 L39-332	21332	Electrode holder assembly (includes L39-374)	1
6 C39-372	21372	Electrode seat	1

Maintenance items

Centricut part number	Reference number	Description	Pkg qty
L39-359	21359	PT-20AM torch body assembly (includes L39-372 and L39-157)	1
L39-157	488157	O-ring	1
027055	N/A	Lubricant .25 oz. (7 ml) tube	1

* Centricut part features a unique Hypertherm design that differs from the OEM design.

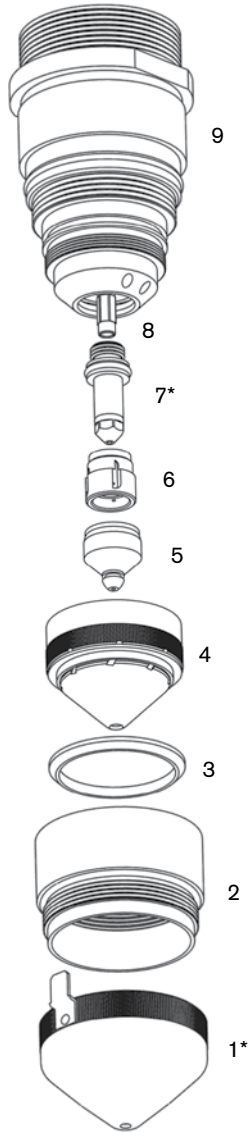

Consumables

Centricut part number	Reference number	Description	Pkg qty
1 C70-531*	22531	Shield, one piece with IHS tab	1
2 C70-712	21712	Shield retainer insulator with o-ring	1
	N/A	Shield without tab	1
3 C70-010	22010	Shield cup insulator	1
4 C70-007	22007	Nozzle retainer diffuser	1
	L70-540	Nozzle A, 15 amp	1
	L70-541	Nozzle B, 30 amp	1
5 C70-542	21542	Nozzle C, 50 amp	5
	C70-543	Nozzle D, 70 amp	5
	C70-923	Nozzle E, 100 amp	5
	L70-852	Swirl baffle, 15 amp	1
	L70-536	Swirl baffle, 30 amp	1
6 C70-692	21692	Swirl baffle, 50 –100 amp	1
7 C70-1039*	21539	SilverLine [®] electrode	1

Maintenance items

Centricut part number	Reference number	Description	Pkg qty
	L70-714	O-ring	1
	L70-797	O-ring	5
	L70-W18	O-ring	5
	L70-W62	O-ring	1
8 L70-725	21725	Water baffle	1
9 L70-758	21758	Torch body	1
	027055	Lubricant .25 oz. (7 ml) tube	1
	L70-765	Tool, electrode and nozzle	1

* Centricut part features a unique Hypertherm design that differs from the OEM design.

OEM ESAB®

System PCM®-8, ESP®-300, ESP-400, ESP-600 and ESP-1000

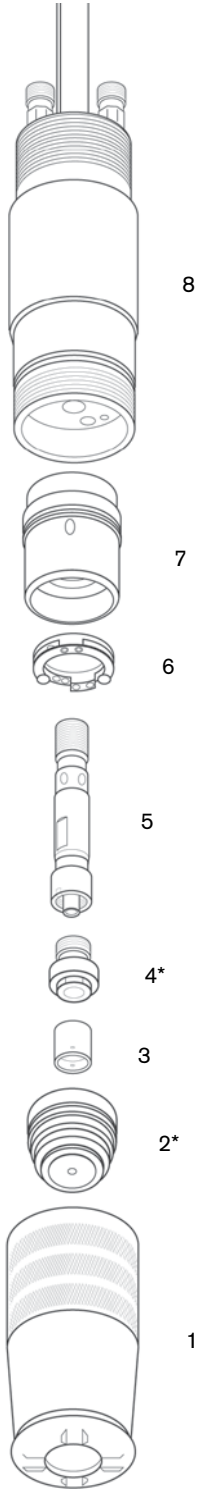

Consumables

Centricut part number	Reference number	Description	Pkg qty
C10-758	20758	Nozzle retaining cap, bevel, PT-15XL	1
1 C10-759	20759	Nozzle retaining cap, PT-15XL	1
C10-230	996230	Nozzle retaining cap, PT-15	1
2 C10-691*	2075691	Nozzle assembly, N ₂ , .125, 250 amp	1
C10-611	2075611	Nozzle assembly, N ₂ , .156, 400 amp	1
C10-614	2075614	Nozzle assembly, N ₂ , .156, reverse swirl	1
C10-612	2075612	Nozzle assembly, N ₂ , .200, 600 amp	1
C10-615	2075615	Nozzle assembly, N ₂ , .200, reverse swirl	1
C10-613	2075613	Nozzle assembly, N ₂ , .230, 750 amp	1
C10-690	2075690	Nozzle assembly, N ₂ , .230, reverse swirl	1
L10-587	2075587	Nozzle assembly, N ₂ , .250, 875 – 1000 amp	1
C10-317	37317	Nozzle, 125 amp, PT-15XL (use with C10-142 and C10-1066)	1
C10-318	N/A	Nozzle base, 125 amp, PT-15XL	1
C10-319	N/A	Nozzle insulator, 125 amp, PT-15XL	1
C10-586	2075586	Gas swirl baffle, ceramic, 8 x .067, 260 amp	1
C10-142	948142	Gas swirl baffle, ceramic, 4 hole, 100 – 280 amp	1
3 C10-341	2075341	Gas swirl baffle, poly, 4 hole	1
C10-360	2075360	Gas swirl baffle, poly, reverse swirl, 4 hole	1
L10-918	20918	Gas swirl baffle, 8 x .067, reverse, 260 amp	1
4 C10-236*	600236	Electrode tip, N ₂	5
5 C10-343	2075343	Electrode tip holder, N ₂	1
6 C10-940	21940	Contact ring assembly	1

Maintenance items

Centricut part number	Reference number	Description	Pkg qty
C10-403	20403	PA bus insulator	1
C10-755	20755	Insulator body with o-ring, PT-15XL	1
7 C10-232	996232	Insulator body with o-ring, PT-15	1
8 C10-754	20754	Torch body, PT-15XL	1
C10-240	996240	Torch body, PT-15	1
C10-483	19483	Double threaded mounting tube	1
C10-932	N/A	O-ring kit, insulator body	1
L10-588	2075588	Insulator, high current nozzle	1
L10-859	21859	Sleeve assembly, air curtain	1
L10-408	20408	High frequency connector	1
L47-110	37110	Electrode holder – removal tool	1
027055	N/A	Lubricant .25 oz. (7 ml) tube	1

* Centricut part features a unique Hypertherm design that differs from the OEM design.

OEM ESAB®

System PCM®-8, ESP®-300, ESP-400, ESP-600 and ESP-1000

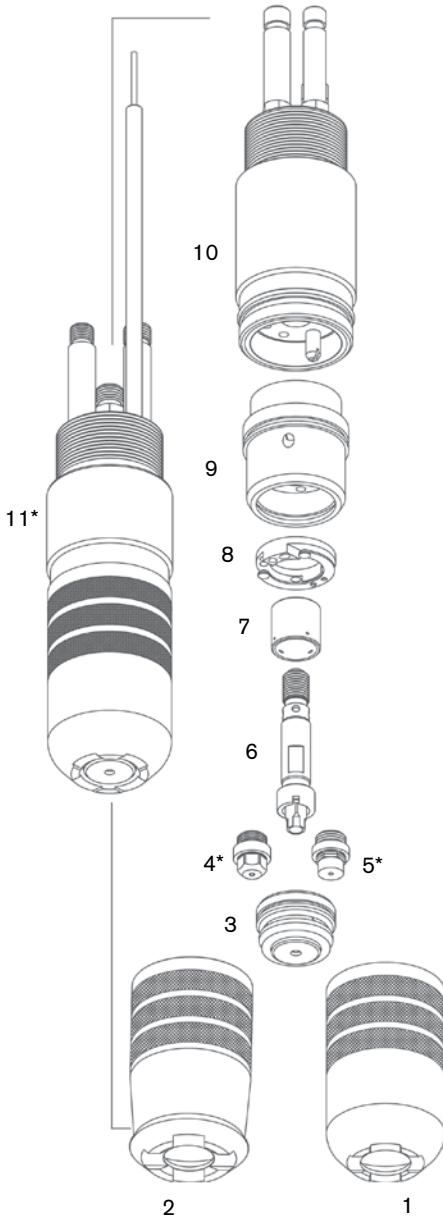

Consumables

Centricut part number	Reference number	Description	Pkg qty	
1	C10-758	20758	Nozzle retaining cap, bevel, PT-15XL	1
2	C10-759	20759	Nozzle retaining cap, PT-15XL	1
	C10-262	21962	Nozzle, 300 amp, bevel	1
	C10-063	21963	Nozzle, 300 amp, reverse bevel	1
	C10-317	37317	Nozzle, 125 amp, PT-15XL (use with C10-142 and C10-1066)	1
	C10-318	N/A	Nozzle base, 125 amp, PT-15XL	1
	C10-661	N/A	Nozzle base, O ₂ , 300 amp	1
	C10-319	N/A	Nozzle insulator, 125 amp, PT-15XL	1
3	C10-751	20751	Nozzle, O ₂ , 260 amp	1
	C10-962	35662	Nozzle, O ₂ , 300 amp	1
	C10-662	35662	Nozzle, O ₂ , 300 amp (replaceable ceramic)	1
	C10-664	35664	Nozzle, O ₂ , 340 – 360 amp	1
	C10-665	35665	Nozzle, O ₂ , 340 – 360 amp, reverse	1
	C10-920	20920	Nozzle, O ₂ , .099, 260 amp, reverse	1
4	C10-1063*	20763	SilverLine® electrode, 260 amp	1
	C47-1096*	34086	SilverLine electrode, 50 – 250 amp, bevel	1
5	C10-1066*	35666	SilverLine electrode, 300 – 360 amp	1
	C10-763*	20763	Electrode, O ₂	1
6	C10-398	20398	Electrode holder, O ₂	1
	C47-084	34084	Electrode holder	1
7	C10-586	2075586	Gas swirl baffle, ceramic, 8 x .067, 260 amp	1
	L10-918	20918	Gas swirl baffle, 8 x .067, reverse, 260 amp	1
	C10-142	948142	Gas swirl baffle, ceramic, 4 hole, 100 – 280 amp	1
	L47-143	948143	Gas swirl baffle, 4 x .032, reverse, 70 – 200 amp	1
	C10-660	35660	Gas swirl baffle, 8 hole, standard, 300 – 600 amp	1
	L47-661	35661	Gas swirl baffle, 8 x .047, reverse, 250 – 400 amp	1
8	C10-940	21940	Contact ring assembly	1

Maintenance items

Centricut part number	Reference number	Description	Pkg qty	
	C10-403	20403	PA bus insulator	1
9	C10-755	20755	Insulator body with o-ring kit	1
	C10-242	996242	Locating pin	1
10	C10-754	20754	Torch body	1
11	C10-954*	16365	Torch assembly, SilverLine, O ₂ , 260 amp (includes items 1 – 10)	1
	C10-955*	16365	Torch assembly, SilverLine, O ₂ , 300 amp (includes items 1 – 10)	1
	C10-483	19483	Double threaded mounting tube	1
	C10-932	N/A	O-ring kit, insulator body	1
	L10-630	999630	Electrode holder removal tool	1
	C10-W99	86W99	O-ring, electrode holder	5
	C10-W85	86W85	O-ring, insulator body center	5
	C10-526	996526	O-ring, insulator body small	5
	C10-527	996527	O-ring, inside insulator body, front	5
	C10-528	996528	O-ring, outside insulator body and torch	5
	C10-106	2064106	O-ring, insulator body rear edge, red	5
	L10-082	21082	Pilot arc bus wire	1
	L10-408	20408	High frequency connector	1
	L47-551	21551	Air curtain sleeve	1
	L47-110	37110	Electrode stem tool	1
	L10-568	996568	Electrode removal tool	1
	L10-4775	34775	Power cable, 4.5 ft.	1
	027055	N/A	Lubricant .25 oz. (7 ml) tube	1

* Centricut part features a unique Hypertherm design that differs from the OEM design.

OEM ESAB®

System PCM®-8, ESP®-300, ESP-400, ESP-600 and ESP-1000

Consumables

Centricut part number	Reference number	Description	Pkg qty
1 C10-628	996628	Gasket	5
2 C10-693	2075693	Insulator, .140	5
C10-617	2075617	Insulator, .180	5
C10-606	2075606	Insulator, .225	5
C10-607	2075607	Insulator, .260	5
3 C10-619	996619	Spacer	5
4 C10-618	996618	Centering sleeve	5
5 C10-584	2075584	Water swirl ring, standard	5
C10-616	2075616	Water swirl ring, reverse	5
6 C10-694	2075694	Nozzle base, .125	5
C10-608	2075608	Nozzle base, .156	5
C10-609	2075609	Nozzle base, .200	5
C10-610	2075610	Nozzle base, .230	5

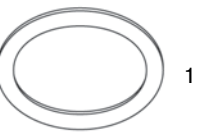
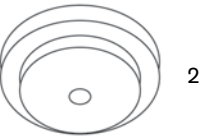
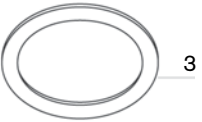
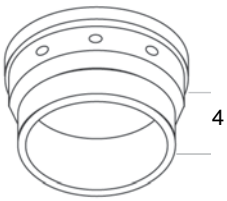
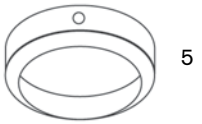

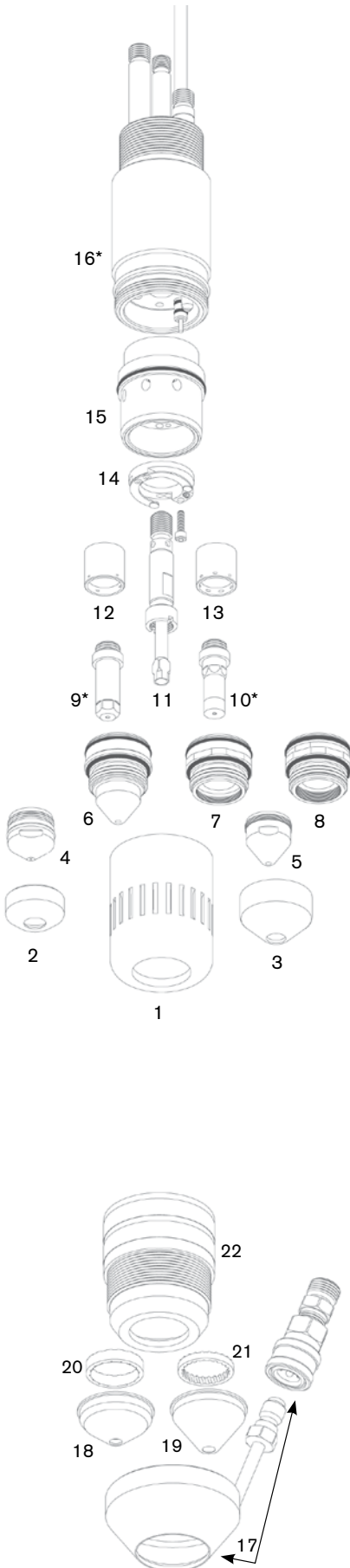

Consumables

Centricut part number	Reference number	Description	Pkg qty
1 L47-085	34085	Nozzle retaining cap	1
C47-082	37082	Nozzle retaining cap	1
2 L47-885	34885	Heat shield, 50 amp	1
3 C47-186	948186	Heat shield, Std, 100 – 360 amp	1
L47-506	19506	Heat shield, heavy duty, 100 – 360 amp	1
4 C47-026	22026	Nozzle tip, .041, 50 amp	1
5 C47-029	22029	Nozzle tip, .071, 100 amp	1
C47-030	22030	Nozzle tip, .082, 150 amp	1
C47-031	22031	Nozzle tip, .091, 200 amp	1
C47-922	22032	Nozzle tip, 250 amp	1
C47-985	22034	Nozzle tip, 360 amp	1
C47-995	22033	Nozzle tip, 400 amp	1
C47-822	21822	Nozzle, .099, 250 amp	1
6 C47-885	35885	Nozzle, .120, 360 amp	1
C47-195	22195	Nozzle, .130, 400 amp	1
C47-027	22027	Nozzle base, 50 amp	1
7 C47-028	22028	Nozzle base, 100 – 400 amp	1
8 C47-928	N/A	Nozzle base, extended life, 100 – 400 amp	1
9 C47-1096*	34086	SilverLine® electrode, 250 amp	1
10 C47-1086*	35886	SilverLine electrode, 360 amp	1
C47-996	34086	Electrode, CopperLine®, 250 amp	1
11 C47-084	34084	Electrode holder	1
12 C47-142	948142	Gas swirl baffle, 4 hole, standard, 100 – 280 amp	1
L47-143	948143	Gas swirl baffle, 4 hole, reverse, 70 – 200 amp	1
C47-586	2075586	Gas swirl baffle, 8 hole, standard, 260 amp	1
13 C10-660	35660	Gas swirl baffle, 8 hole, standard, 300 – 600 amp	1
L10-918	20918	Gas swirl baffle, 8 hole, reverse, 260 amp	1
14 C47-940	21940	Contact ring assembly	1

Maintenance items

Centricut part number	Reference number	Description	Pkg qty
C10-403	20403	PA bus insulator	1
15 C47-434	20434	Insulator assembly	1
16 C47-391*	20391	PT-19XL torch body	1
C47-990*	N/A	Torch assembly, SilverLine, 150 amp	1
C47-991*	N/A	Torch assembly, SilverLine, 250 amp	1
C47-992*	N/A	Torch assembly, SilverLine, 360 amp	1
L47-110	37110	Electrode holder – removal tool	1
C14-793	85W10	O-ring, rear insulator	3
C10-W99	86W99	O-ring, electrode holder	5
C47-528	996528	O-ring, outside insulator body and torch	5
C47-999	N/A	O-ring kit, insulator body	1
C10-106	2064106	O-ring, insulator body rear edge, red	5
C47-W85	86W85	O-ring, insulator body center	5
C47-526	996526	O-ring, insulator body small	5
C47-527	996527	O-ring, inside insulator body	5
C10-483	19483	Double threaded mounting tube	1
L47-551	21551	Air curtain sleeve	1
L10-408	20408	High frequency connector	1
L10-4775	34775	Power cable, 4.5 ft.	1
L10-568	996568	Electrode removal tool	1
C47-006	181W89	O-ring, nozzle	5
027055	N/A	Lubricant .25 oz. (7 ml) tube	1

PT-19XL+S

Consumables

Centricut part number	Reference number	Description	Pkg qty
17 L47-801	21801	Shield retainer assembly	1
18 L47-795	21795	Shield, 50 amp	5
19 C47-802	21802	Shield, 100 – 250 amp	1
C47-945	21945	Shield, 300 – 400 amp	1
20 L47-796	21796	Diffuser, 50 amp	1
21 C47-944	21944	Diffuser, 100 – 600 amp	1
22 L47-982	21982	Nozzle retaining cup	1

* Centricut part features a unique Hypertherm design that differs from the OEM design.

Consumables

Centricut part number	Reference number	Description	Pkg qty	
1	C47-081	37081	Shield retainer	1
2	L47-795	21795	Shield, 50 amp	5
3	C47-802	21802	Shield, 100 – 250 amp	1
	C47-945	21945	Shield, 325 – 600 amp	1
4	L47-796	21796	Diffuser, 50 amp	1
5	C47-944	21944	Diffuser, 100 – 600 amp	1
	C47-496	22496	Diffuser, 100 – 600 amp, reverse, black	1
6	C47-082	37082	Nozzle retaining cap	1
	L47-431	37431	Nozzle retaining cap, air curtain	1
7	C47-027	22027	Nozzle base, 50 amp	1
8	C47-028	22028	Nozzle base, 100-360 amp	1
9	C47-928	N/A	Nozzle base, extended life, 100-400 amp	1
10	C47-026	22026	Nozzle tip, .041, 50 amp	1
11	C47-029	22029	Nozzle tip, .071, 100 amp	1
	C47-030	22030	Nozzle tip, .082, 150 amp	1
	C47-031	22031	Nozzle tip, .091, 200 amp	1
	C47-922	22032	Nozzle tip, 250 amp	1
	C47-985	22034	Nozzle tip, 360 amp	1
	C47-995	22033	Nozzle tip, 400 amp	1
12	C47-822	21822	Nozzle, .099, 250 amp	1
	C47-885	35885	Nozzle, .120, 360 amp	1
	C47-195	22195	Nozzle, .130, 400 amp	1
	L47-401	22401	Nozzle, 600 amp	1
13	C47-1096	34086	SilverLine® electrode, 50 – 250 amp	1
14	C47-1086	35886	SilverLine electrode, 360 amp	1
	C47-996	34086	Electrode, CopperLine®, 250 amp	1
	L47-196	22196	Electrode, 400 amp	1
	L47-403	22403	Electrode, N ₂ /ArH ₂ , 600 amp	5
16	C47-142	948142	Gas swirl baffle, 4 hole, standard, 100 – 280 amp	1
	L47-143	948143	Gas swirl baffle, 4 hole, reverse, 70 – 200 amp	1
	C47-586	2075586	Gas swirl baffle, 8 hole, standard, 260 amp	1
17	C10-660	35660	Gas swirl baffle, 8 hole, standard, 300 – 600 amp	1
	L47-194	22194	Gas swirl baffle, standard, 400 amp	1
	C122-530R	0558002530R	Gas swirl baffle, 8 x .047, reverse, 360 – 450 amp	1
18	C47-073	37073	Screw, contact ring	1
19	C47-071	37071	Contact ring assembly	1

Maintenance items

Centricut part number	Reference number	Description	Pkg qty	
	C47-528	996528	O-ring, outside insulator body and torch	5
	C10-106	2064106	O-ring, insulator body rear edge, red	5
20	C47-083	37083	Insulator body	1
22	C47-900	N/A	Insulating tube kit, PT-19XLS/PT-600	1
15	C47-068	37068	Electrode holder	1
21	C47-066	37066	Torch body	1
	C47-993	N/A	Torch assembly, SilverLine, 250 amp	1
	C47-994	N/A	Torch assembly, SilverLine, 360 amp	1
	C10-483	19483	Double threaded mounting tube	1
	C10-033	951000	O-ring, Teflon® tubes	5
	C10-W85	86W85	O-ring, insulator body center	1
	C10-106	2064106	O-ring, insulator body rear edge, red	5
	C47-998	N/A	O-ring kit, insulator body	1
	C47-528	996528	O-ring, insulator assembly	1
	C47-006	181W89	O-ring, nozzle	1
	L47-110	37110	Electrode holder removal tool	1
	L10-408	20408	High frequency connector	1
	C47-900	N/A	Insulating tube kit, PT-19XLS/PT-600	1
	L47-063	37063	Locating pin	1
	L47-075	37075	P.A. collet and wire assembly	1
	027055	N/A	Lubricant .25 oz. (7 ml) tube	1

Centricut, SilverLine and CopperLine are registered trademarks of Hypertherm, Inc. and may be registered in the United States and/or other countries. All other trademarks are the properties of their respective owners. Centricut is in no way affiliated with ESAB.

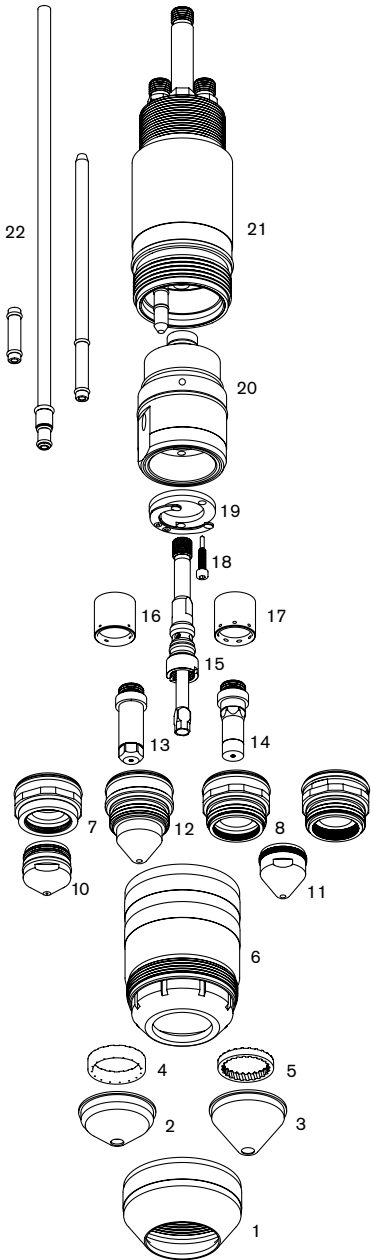

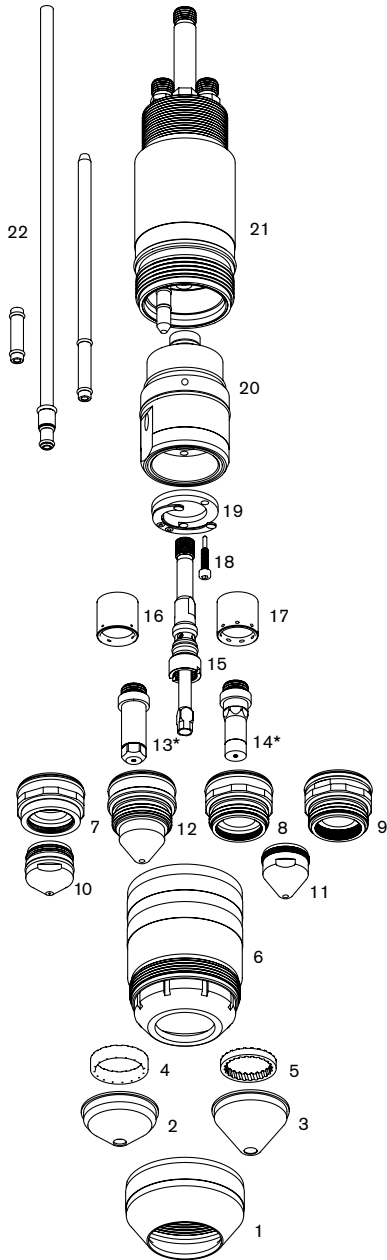

Consumables

Centricut part number	Reference number	Description	Pkg qty
1 C47-081	37081	Shield retainer	1
2 L47-795	21795	Shield, 50 amp	5
3 C47-802	21802	Shield, 100 – 250 amp	1
C47-945	21945	Shield, 325 – 600 amp	1
L96-4678	0558004678	Shield	5
4 L47-796	21796	Diffuser, 50 amp	1
5 C47-944	21944	Diffuser, 100 – 600 amp	1
C47-496	22496	Diffuser, 100 – 600 amp, reverse, black	1
6 C47-082	37082	Nozzle retaining cap	1
L47-431	37431	Nozzle retaining cap, air curtain	1
7 C47-027	22027	Nozzle base, 50 amp	1
8 C47-028	22028	Nozzle base, 100 – 360 amp	1
9 C47-928	N/A	Nozzle base, extended life, 100 – 400 amp	1
10 C47-026	22026	Nozzle tip, .041, 50 amp	1
11 C47-029	22029	Nozzle tip, .071, 100 amp	1
C47-030	22030	Nozzle tip, .082, 150 amp	1
C47-031	22031	Nozzle tip, .091, 200 amp	1
C47-922	22032	Nozzle tip, 250 amp	1
C47-985	22034	Nozzle tip, 360 amp	1
C47-995	22033	Nozzle tip, 400 amp	1
12 C47-822	0558001623	Nozzle, .099, 250 amp	1
C47-885	0558001885	Nozzle, .120, 360 amp	1
C47-195	0558001886	Nozzle, .130, 400 amp	1
L47-401	0558001887	Nozzle, 600 amp	1
13 C96-1024*	0558001624	SilverLine® electrode, 250 amp	1
14 C96-1016*	0558002516	SilverLine electrode, 360/400 amp	1
L96-2499	0558002499	Electrode, N ₂	1
15 C96-621	0558001621	Electrode holder	1
16 C47-142	0558002533	Gas swirl baffle, 4 hole, standard, 100 – 280 amp	1
L47-143	0558002534	Gas swirl baffle, 4 hole, reverse, 70 – 200 amp	1
L47-661	35661	Gas swirl baffle, 8 hole, reverse, 250 – 400 amp	1
17 C10-660	0558001625	Gas swirl baffle, 8 hole, standard, 300 - 600 amp	1
L47-194	22194	Gas swirl baffle, standard, 400 amp	1
C122-530R	0558002530R	Gas swirl baffle, 8 x .047, reverse, 360 – 450 amp	1

Maintenance items

Centricut part number	Reference number	Description	Pkg qty
18 C47-073	37073	Screw, contact ring assembly	1
19 C47-071	37071	Contact ring assembly	1
C47-528	996528	O-ring, outside insulator body and torch	5
C47-998	N/A	O-ring, kit, insulator body	1
C10-483	19483	Double threaded mounting tube	1
20 C47-083	37083	Insulator body	1
22 C47-900	N/A	Insulating tube kit, PT-19XLS/PT-600	1
C96-925	0558001825	Torch body, modular	1
21 C47-066	37066	Torch body	1
C96-993*	N/A	Torch assembly, SilverLine, 250 amp	1
C96-994*	N/A	Torch assembly, SilverLine, 360 amp	1
L96-4611	0558004611	Electrode, holder, tool	1
L10-4775	34775	Power cable, 4.5 ft.	1
027055	N/A	Lubricant .25 oz. (7 ml) tube	1

* Centricut part features a unique Hypertherm design that differs from the OEM design.

OEM ESAB®

System ESP®-200/300/400-600C/1000, PCM®-150/1500/8XL

Consumables

Centricut part number	Reference number	Description	Pkg qty
1 C47-081	37081	Shield retainer	1
2 C120-920*	N/A	MultiPort shield, 200	1
C120-900	N/A	MultiPort shield, 260 amp	1
C120-936	N/A	MultiPort shield, 360 amp	1
3 C47-944	21944	Diffuser, 100 – 600 amp	1
4 C47-082	37082	Nozzle retaining cap	1
5 C120-200	N/A	CoolFlow™ nozzle tip, 200 amp	1
C120-260	N/A	CoolFlow nozzle tip, 260 amp	1
C120-360	N/A	CoolFlow nozzle tip, 360 amp	1
15 C120-2200*	N/A	CoolFlow nozzle kit, 200 amp, 20 pack	1
C120-2260*	N/A	CoolFlow nozzle kit, 260 amp, 20 pack	1
C120-2360*	N/A	CoolFlow nozzle kit, 360 amp, 20 pack	1
6 C120-010*	N/A	CoolFlow nozzle base	1
7 C120-020*	N/A	Baffle, coolant	1
8 C120-030*	N/A	CoolFlow nozzle base assembly	1
9 C120-1010*	N/A	SilverLine® electrode	1
10 C96-621	0558001621	Electrode holder	1
11 C10-660	0558001625, 35660	Gas swirl baffle, 8 hole, standard, 300 – 600 amp	1
C47-142	0558002533, 948142	Gas swirl baffle, 4 hole, 100 – 280 amp	1

Maintenance items

Centricut part number	Reference number	Description	Pkg qty
12 C47-073	37073	Screw, contact ring assembly	1
13 C47-071	37071	Contact ring assembly	1
14 C47-083	37083	Insulator body	1
15 C47-066	37066	Torch body	1
C96-925	0558001825	Torch body modular	1
C47-006	181W89	O-ring, nozzle	5
C47-998	N/A	O-ring, kit, insulator bod	1
C120-012	N/A	Wrench, elec/nozzle	1
C120-013	N/A	Wrench, nozzle base	1

* Centricut part features a unique Hypertherm design that differs from the OEM design.

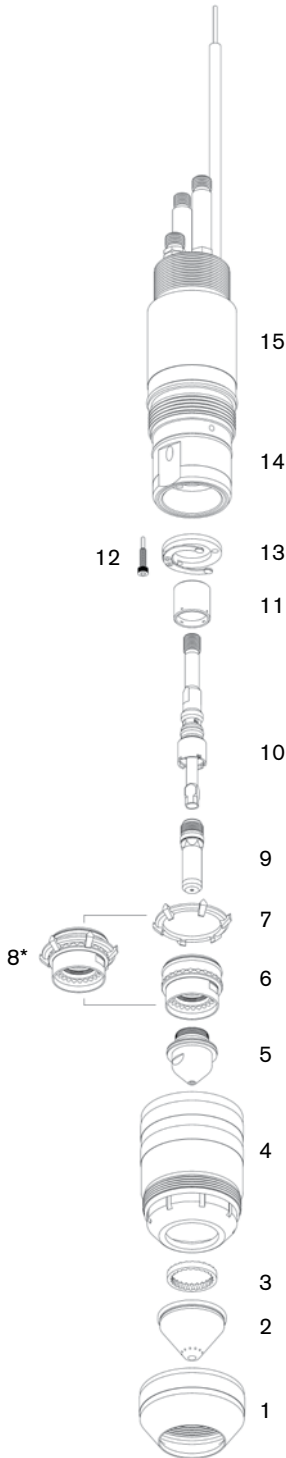

Significantly improve:

Consumable Life

Cutting speed

Cut quality

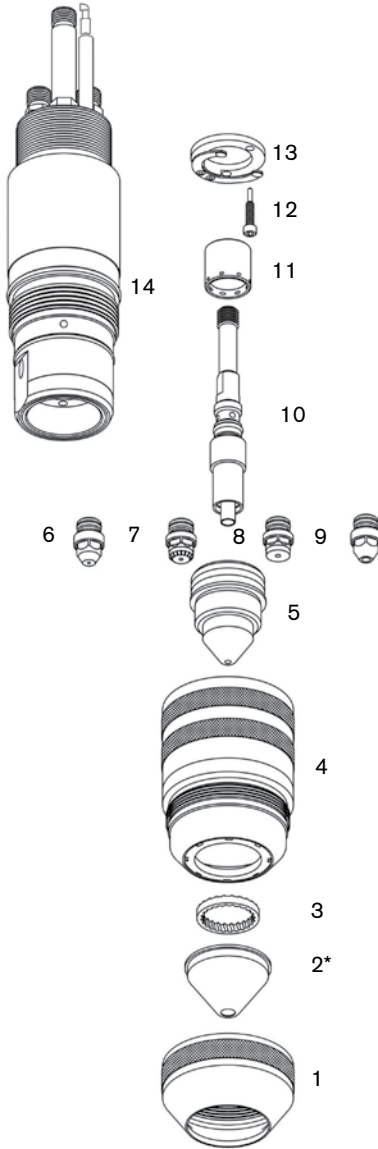

Consumables

Centricut part number	Reference number	Description	Pkg qty
1 C47-081	37081	Shield retainer	1
L122-616	0558004616	Shield retainer, insulated	1
2 C122-624	0558007624	Shield, 2.4 mm, 45 – 55 amp	1
C122-130	0558006130	Shield, 3.0 mm, 35 – 50 amp	1
C122-141	0558006141	Shield, 4.1 mm, 100 – 280 amp	1
C122-166	0558006166	Shield, 6.6 mm, 260 – 450 amp	1
C122-199	0558006199	Shield, 9.9 mm, 360 – 600 amp	1
3 L47-796	21796	Diffuser, 50 amp	1
C47-944	21944	Diffuser, 100 – 600 amp	1
4 C47-082	37082	Nozzle retaining cap	1
5 C122-908	0558006908	Nozzle, CoolFlow™, .8 mm, 35 amp	1
C122-8010	0558008010	Nozzle, CoolFlow, 1.0 mm, PR, 45 – 55 amp	1
C122-6010	0558006010	Nozzle, CoolFlow, 1.0 mm, 50 amp	1
C122-014	0558006014	Nozzle, CoolFlow, 1.4 mm, 100 amp	1
C122-018	0558006018	Nozzle, CoolFlow, 1.8 mm, 130 amp	1
C122-020	0558006020	Nozzle, CoolFlow, 2.0 mm, 200 amp	1
C122-023	0558006023	Nozzle, CoolFlow, 2.3 mm, 280 amp	1
C122-025	0558006025	Nozzle, CoolFlow, 2.5 mm, 300 amp	1
C122-030	0558006030	Nozzle, CoolFlow, 3.0 mm, 360 amp	1
C122-036	0558006036	Nozzle, CoolFlow, 3.6 mm, 450 amp	1
C122-041	0558006041	Nozzle, CoolFlow, 4.1 mm, 600 amp	1
6 C122-1059	0558005459	Electrode, SilverLine [®] , O ₂ , 50 amp	1
7 C122-1014	0558003914	Electrode, SilverLine, O ₂ , 100 – 300 amp	1
8 C122-1091	0558007791	Electrode, SilverLine, O ₂ , 360 – 450 amp	1
9 C122-928	0558003928	Electrode, SS/AL, 600 amp	1
10 C122-924	0558003924	Electrode holder	1
11 C122-457	0558005457	Gas swirl baffle, 4X.022, 35 – 70 amp	1
C122-533	0558002533	Gas swirl baffle, 4X.032, 100 – 280 amp	1
C122-530R	0558002530R	Gas swirl baffle, 8X.047, reverse, 360 – 450 amp	1
C10-660	0558001625	Gas swirl baffle, 8X.047, 300 – 600 amp	1

Maintenance items

Centricut part number	Reference number	Description	Pkg qty
12 C47-073	37073	Screw, contact ring	1
13 C47-071	0558003858	Contact ring assembly	1
C10-483	0558001626	Double threaded mounting tube	1
14 C122-804	0558003804	Torch body	1

New technology improvements!

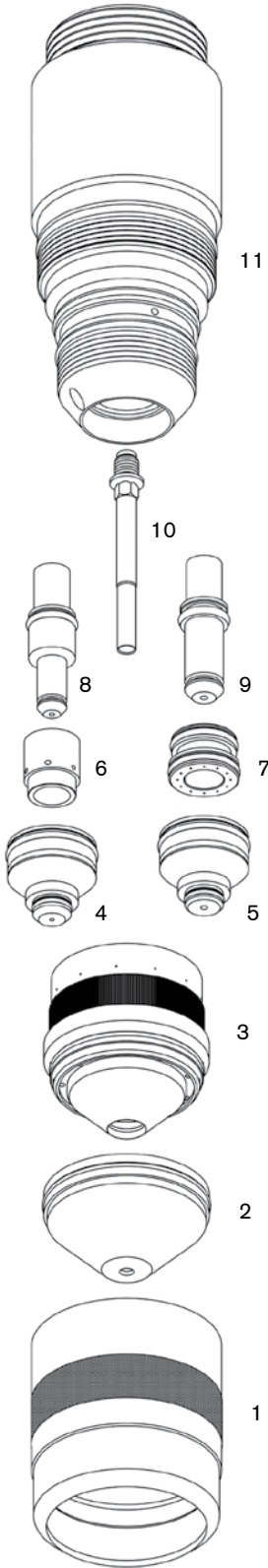

Consumables

Centricut part number	Reference number	Description	Pkg qty
1 C104-210	200210	Outer cap	1
2 I104-230	200230	Shield cap, 30 amp, MS/AL	1
I104-233	200233	Shield cap, 30 amp, SS	1
I104-237	200237	Shield cap, 50 amp, SS	1
C104-231	200231	Shield cap, 50 – 70 amp, MS/SS/AL	1
C104-232	200232	Shield cap, 100 amp, MS/SS/AL	1
C104-234	200234	Shield cap, 200 amp, MS/SS/AL	1
3 C104-217	200217	Retaining cap, 30/50/70 amp, MS	1
C104-218	200218	Retaining cap, 100 amp, MS	1
C107-266	277266, 200219	Retaining cap, 200/275 amp, MS/SS/AL	1
I104-222	200222	Nozzle, 30 amp, MS/AL	1
I104-228	200228	Nozzle, 30 amp, SS	1
I104-229	200229	Nozzle, 50 amp, SS	1
C104-223	200223	Nozzle, 50 amp, MS/AL	1
C104-224	200224	Nozzle, 70 amp, MS	1
I104-240	200240	Nozzle, 70 amp, AL/SS	1
4 C104-225	200225	Nozzle, 100 amp, MS	1
C104-239	200239	Nozzle, 100 amp, AL/SS	1
5 C104-227	200227	Nozzle, 200 amp, MS/SS/AL	1
I104-0274	200274	Nozzle, 200 amp, SS	1
I104-279	200279	Swirl ring, 30 amp, SS	1
6 C104-277	200277	Swirl ring, 100 amp, MS	1
7 C104-221	200221	Swirl ring, 200 amp, MS	1
I104-213	200213	Electrode, 30 amp, MS/AL	1
I104-238	200238	Electrode, 30 – 50 amp, SS	1
C104-214	200214	Electrode, 50 – 70 amp, MS	1
8 C104-1005	200215	Electrode, SilverLine®, 100 amp, MS	1
C104-215	200215	Electrode, 100 amp, MS	1
C104-115	202115	Electrode, 200 amp, MS	1
I104-111	202111	Electrode, 200 amp, SS	1
9 C104-1015	202115	Electrode, SilverLine, 200 amp, MS	1

Maintenance items

Centricut part number	Reference number	Description	Pkg qty
10 C104-112	200112	Cooling tube	1
C104-109	200109	Wrench, cooling tube	1
I104-390	200390	Nozzle removal tool	1
C104-017	N/A	O-ring	5
I104-024	500024	O-ring	1
I104-018	500018	O-ring	1
I104-209	820209	O-ring	1
I104-200	200000	Torch body	1
027055	N/A	O-ring lube	1

OEM Kaliburn®

System ProLine 2150, 2200, 2260
FineLine150, 200, 260

Consumables

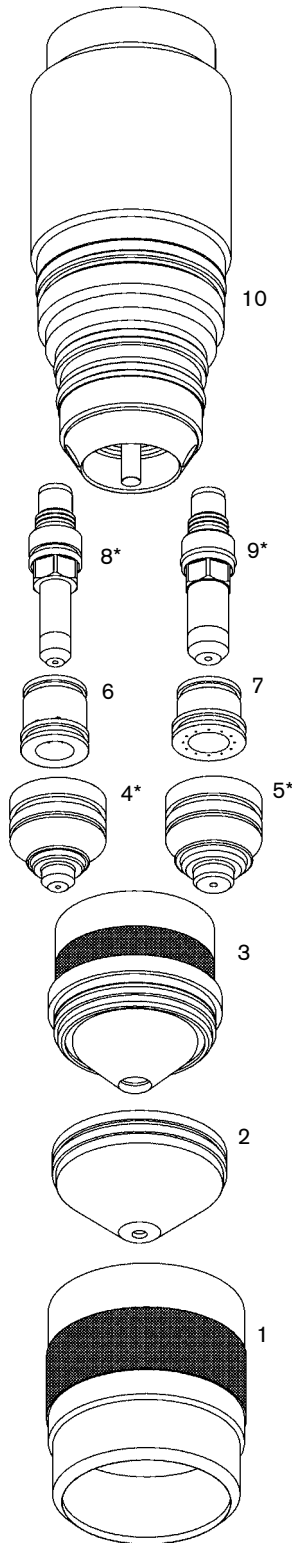

Centricut part number	Reference number	Description	Pkg qty
1 C107-154	277154	Outer cap	1
2 I107-145	277145	Shield cap, 30 amp, MS/AL	1
I107-144	277144	Shield cap, 30 amp, SS	1
C107-115	277115	Shield cap, 50 amp, MS	1
I107-149	277149	Shield cap, 50 amp, SS	1
C107-150	277150	Shield cap, 70 amp, MS/SS/AL	1
C107-147	277147	Shield cap, 100 amp	1
C107-117	277117	Shield cap, 150 amp, MS/SS/AL	1
C107-274	277274	Shield cap, 200 amp, MS/SS/AL	1
C107-148	277148	Shield cap, 200 amp, SS	1
C107-263	277263	Shield cap, 275 amp, MS/SS/AL	1
3 I107-110	277110	Retaining cap, 30/150 amp, SS	1
C107-153	277153	Retaining cap, 30/50/70 amp, MS/SS/AL	1
C107-151	277151	Retaining cap, 100/150 amp, MS/SS/AL	1
C107-152	277152	Retaining cap, 150 amp, MS/SS/AL	1
I107-113	277113	Retaining cap, 200 amp, SS	1
C107-266	277266	Retaining cap, 200/275 amp, MS/SS/AL	1
4 C107-122*	277122	CoolFlow™ nozzle, 50 amp, MS/AL	1
C107-125*	277125	CoolFlow nozzle, 70 amp, MS/SS/AL	1
C107-127*	277127	CoolFlow nozzle, 100 amp, MS	1
C107-119*	277119	CoolFlow nozzle 150 amp, MS	1
5 C107-268*	277268	CoolFlow nozzle, 200 amp, MS	1
C107-269*	277269	CoolFlow nozzle 275 amp, MS	1
I107-120	277120	Nozzle, 30 amp, MS/AL	1
I107-121	277121	Nozzle, 30 amp, SS	1
I107-123	277123	Nozzle, 50 amp, SS	1
I107-114	277114	Nozzle, 200 amp, SS/AL	1
I107-276	277276	Nozzle, 275 amp, SS/AL	1
6 I107-138	277138	Swirl ring, 30 amp, SS	1
I107-140	277140	Swirl ring, 30/70 amp, MS/SS/AL	1
C107-142	277142	Swirl ring, 50/70/100 amp, MS/SS/AL	1
C107-139	277139	Swirl ring, 150 amp, MS/SS/AL	1
7 C107-259	277259	Swirl ring, 200 amp, SS	1
C107-143	277143	Swirl ring, 200 amp, MS/SS/AL	1
C107-258	277258	Swirl ring, 275 amp, MS/SS/AL	1
I107-130	277130	Electrode, 30 amp, MS/AL	1
I107-137	277137	Electrode, 30/50 amp, SS	1
C107-131	277131	Electrode, 50/70 amp, MS/SS/AL	1
8 C107-1034*	277134	SilverLine® electrode, 100 amp, MS	1
9 C107-1036*	277136	SilverLine electrode, 150/200 amp, MS	1
C107-1070*	277270	SilverLine electrode, 275 amp, MS/SS/AL	1
I107-190	277190	Electrode, marking	1

Maintenance items

Centricut part number	Reference number	Description	Pkg qty
10 I107-7000	277000	Torch body	1
I104-024	500024	O-ring, blue	1
I104-018	500018	O-ring, orange	1
I104-209	820209	O-ring, orange	1
I107-007	277007	Cooling tube	1
I107-105	260105	Swirl ring removal tool	1
I107-056	277056	Nozzle removal tool	1
027055	N/A	Lubricant .25 oz. (7 ml) tube	1

* Centricut part features a unique Hypertherm design that differs from the OEM design.

Many of these parts can be used with the Kaliburn Spirit systems. Contact Hypertherm for details and assistance with part selection.

Centricut and SilverLine are registered trademarks of Hypertherm, Inc. and may be registered in the United States and/or other countries. All other trademarks are the properties of their respective owners. Centricut is in no way affiliated with Kaliburn.

OEM Kaliburn[®] System SR-45i[®]

Consumables

Centricut part number	Reference number	Description	Pkg qty
1 I36-098	770098	Retaining cap	1
2 C36-030	770030	Nozzle, insulation	5
3 C36-104	770104	Nozzle, tapered	5
4 C36-000	770000	Nozzle, Air	5
5 C36-012	770012	Swirl ring	1
6 C36-715*	770015/ 770017	Electrode, Air	5

Maintenance items

Centricut part number	Reference number	Description	Pkg qty
I36-073	770073	Torch body	1
136-072	770072	O-ring	5
027055	N/A	Lubricant .25 oz. (7 ml) tube	1

* Centricut part features a unique Hypertherm design that differs from the OEM design.

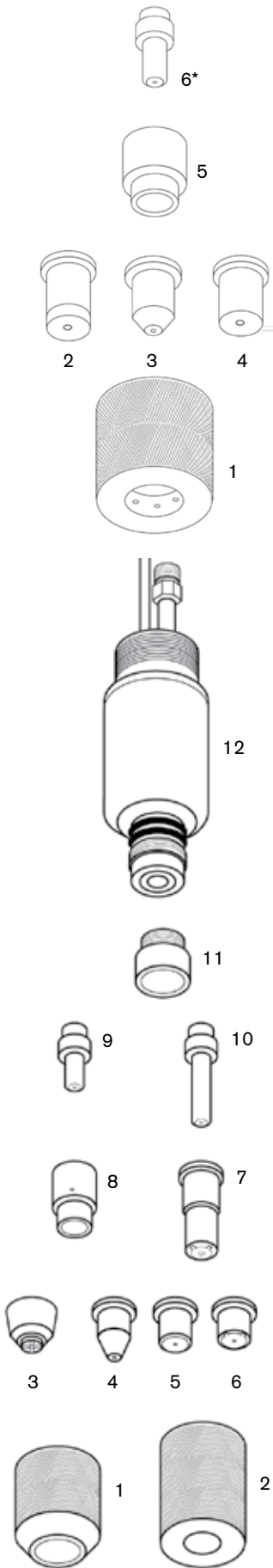

SR-45i[®] Retrofit

OEM Kaliburn[®] System SR-45i[®] Retrofit

Consumables

Centricut part number	Reference number	Description	Pkg qty
1 020200	020200	Retaining cap, high visibility	1
2 C02-104	020104	Retaining cap	1
3 020197	020197	Nozzle, high visibility	5
4 C02-131	020131	Nozzle, pipe	10
5 C02-102	020102	Nozzle	10
6 C02-115	020115	Nozzle	10
7 020466	020466	Nozzle, extended	5
020340	020340	Nozzle, gouging	5
8 C02-101	020101	Swirl ring	2
9 C02-103	020103	Electrode, Air	10
020167	020167	Electrode, N ₂	5
10 020467	020467	Electrode, Air, extended	5

Maintenance items

Centricut part number	Reference number	Description	Pkg qty
C02-016	044016	O-ring	5
11 C02-043	N/A	Insulator, replaceable	1
12 C36-973	N/A	Retrofit modular torch body	1
027055	N/A	Lubricant .25 oz. (7 ml) tube	1

OEM Kjellberg®

System FineFocus®800, PA-S70, PA-S75®

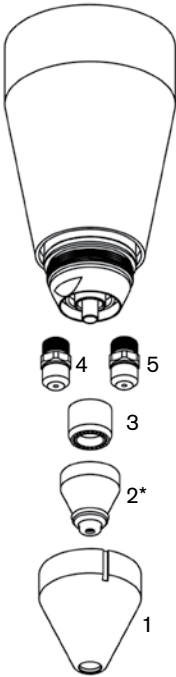

Consumables

Centricut part number	Reference number	Description	Pkg qty
1 C53-790	.12.37790	Nozzle cap	1
2 C53-920*	.11.828.901.420	CoolFlow™ nozzle, L1-XL, O ₂ , 160 amp	1
C53-925*	.11.828.901.425	CoolFlow nozzle, L2-XL, O ₂ , 250 amp	1
C53-927*	.11.828.901.427	CoolFlow nozzle, L4-XL, O ₂ , 300 amp	1
3 C53-860	.12.40860	Gas guide	1
4 C53-1000*	.11.828.921.300	SilverLine® electrode, K2-XL, O ₂	1
C53-870	.12.40870	Electrode, K2, Air	5
K53-500	.12.48500	Removal tool	1

* Centricut part features a unique Hypertherm design that differs from the OEM design.

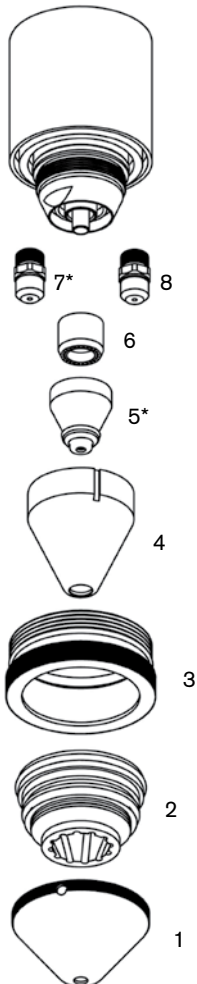

PB-S77®

OEM Kjellberg®

System FineFocus®800, 900®

Consumables

Centricut part number	Reference number	Description	Pkg qty
1 K53-1156	.11.833.111.156	Swirl gas cap, 4.0	1
C53-158	.11.833.101.158	Swirl gas cap, 5.0	1
2 K53-271	.11.833.101.271	Swirl gas nozzle	1
3 K53-261	.11.833.101.261	Protective cap	1
4 C53-790	.12.37790	Nozzle cap	1
5 C53-920*	.11.828.901.420	CoolFlow™ nozzle, L1-XL, 160 amp	1
C53-925*	.11.828.901.425	CoolFlow nozzle, L2-XL, 250 amp	1
C53-927*	.11.828.901.427	CoolFlow nozzle, L4-XL, 300 amp	1
6 C53-860	.12.40860	Gas guide	1
7 C53-1000*	.11.828.921.300	SilverLine® electrode, K2-XL	1
C53-870	.12.40870	Electrode, K2	5
K53-500	.12.48500	Removal tool	1

* Centricut part features a unique Hypertherm design that differs from the OEM design.

Consumables – Carbon steel

Centricut part number	Reference number	Alternate reference	Description	Pkg qty
1 C106-081	.11.835.201.081	Z501	Protection cap	1
2 C106-561	.11.835.201.1561	Z4015	Swirl gas cap, 1.5 mm	1
C106-571	.11.835.201.1571	Z4020	Swirl gas cap, 2.0 mm	1
C106-581	.11.835.201.1581	Z4025	Swirl gas cap, 2.5 mm	1
C106-591	.11.835.201.1591	Z4030	Swirl gas cap, 3.0 mm	1
C106-171	.11.835.401.1571	Z4140	Swirl gas cap, 4.0 mm	1
5 C106-406	.11.835.221.406	Z2006	Nozzle, 0.6 mm	10
C106-407	.11.835.221.407	Z2007	Nozzle, 0.7 mm	10
C106-408	.11.835.221.408	Z2008	Nozzle, 0.8 mm	10
C106-409	.11.836.221.409	Z2009	Nozzle, 0.9 mm	10
C106-410	.11.835.221.410	Z2010	Nozzle, 1.0 mm	10
C106-411	.11.835.221.411	Z2011	Nozzle, 1.1 mm	10
C106-412	.11.835.421.412	Z2112	Nozzle, 1.2 mm	10
C106-112	.11.835.221.412	Z2012	Nozzle, 1.2 mm	10
C106-414	.11.835.421.414	Z2114	Nozzle, 1.4 mm	10
4 C106-160	.11.835.201.160	Z3004	Nozzle cap, complete, 0.4 mm	1
C106-162	.11.835.201.162	Z3008	Nozzle cap complete, 0.8 mm	1
7 C106-153	.11.835.221.153	Z101	Gas guiding cap, 0.4 mm	1
8 K106-253	.11.834.321.153	Z111	Gas guide cap	1
9 C106-303	.11.835.421.303	Z111A	Spacer	1
10 C106-1021*	.11.835.421.3101	Z012	SilverLine® electrode	1
C106-1001*	.11.835.221.3101	Z002	SilverLine electrode	1

Consumables – Stainless steel and aluminum

Centricut part number	Reference number	Alternate reference	Description	Pkg qty
1 C106-081	.11.835.201.081	Z501	Protection cap	1
3 C106-1571	.11.835.411.1571	Z4520	Swirl gas cap, 2.0 mm	1
C106-1581	.11.835.411.1581	Z4530	Swirl gas cap, 3.0 mm	1
C106-1591	.11.835.411.1591	Z4540	Swirl gas cap, 4.0 mm	1
4 C106-162	.11.835.201.162	Z3008	Nozzle cap complete, 0.8 mm	1
5 C106-406	.11.835.221.406	Z2006	Nozzle, 0.6 mm	10
C106-407	.11.835.221.407	Z2007	Nozzle, 0.7 mm	10
C106-408	.11.835.221.408	Z2008	Nozzle, 0.8 mm	10
C106-410	.11.835.221.410	Z2010	Nozzle, 1.0 mm	10
6 C106-610	.11.835.411.610	Z2510	Nozzle, 1.0 mm	5
C106-612	.11.835.411.612	Z2512	Nozzle, 1.2 mm	5
C106-614	.11.835.411.614	Z2514	Nozzle, 1.4 mm	5
C106-616	.11.835.411.616	Z2516	Nozzle, 1.6 mm	5
7 C106-153	.11.835.221.153	Z101	Gas guiding cap, 0.4 mm	1
8 K106-253	.11.834.321.153	Z111	Gas guide cap	1
9 C106-303	.11.835.421.303	Z111A	Spacer	1
11 C106-101	.11.835.211.5101	Z042	Electrode	1
C106-5101	.11.835.411.5101	Z052	Electrode	1

Maintenance items

Centricut part number	Reference number	Alternate reference	Description	Pkg qty
027055	N/A		O-ring lube	1

* Centricut part features a unique Hypertherm design that differs from the OEM design.

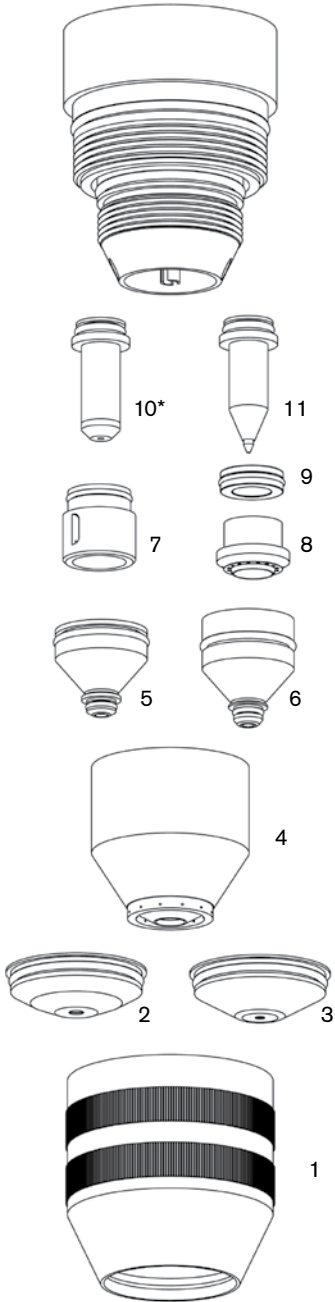

OEM Kjellberg®

System HiFocus 130/160i® and HiFocus 280i/360i/440i

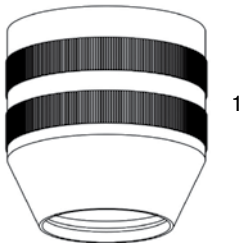
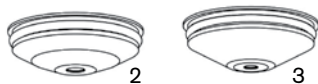
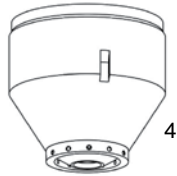
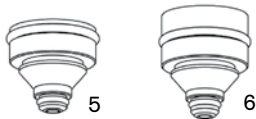
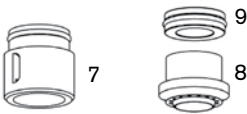
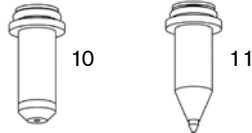

Consumables – Carbon steel

Centricut part number	Reference number	Alternate reference	Description	Pkg qty
1 C106-081	.11.835.201.081	Z501	Protection cap	1
2 C106-561	.11.835.201.1561	Z4015	Swirl gas cap, 1.5 mm	1
C106-571	.11.835.201.1571	Z4020	Swirl gas cap, 2.0 mm	1
C109-551	.11.835.201.1551	Z4022	Swirl gas cap, 2.2 mm	1
C106-581	.11.835.201.1581	Z4025	Swirl gas cap, 2.5 mm	1
C106-591	.11.835.201.1591	Z4030	Swirl gas cap, 3.0 mm	1
C106-171	.11.835.401.1571	Z4140	Swirl gas cap, 4.0 mm	1
4 K109-160	.11.842.401.160	S3004	Nozzle cap, 0.4 mm	1
C109-162	.11.842.401.162	S3008	Nozzle cap, 0.8 mm	1
K109-622	.11.842.401.1622	S3028	Nozzle cap, 0.8 mm	1
5 C109-406	.11.843.021.406	S2006X	Nozzle, 0.6 mm, 25 amp	10
C109-407	.11.843.021.407	S2007X	Nozzle, 0.7 mm, 35 amp	10
C109-408	.11.843.021.408	S2008X	Nozzle, 0.8 mm, 50/60 amp	10
C109-409	.11.843.021.409	S2009X	Nozzle, 0.9 mm, 70/80 amp	10
C109-410	.11.843.021.410	S2010X	Nozzle, 1.0 mm, 80/90 amp	10
C109-411	.11.843.021.411	S2011X	Nozzle, 1.1 mm, 90/100 amp	10
C109-112	.11.843.121.412	S2112X	Nozzle, 1.2 mm, 100 amp	10
C109-412	.11.843.021.412	S2012X	Nozzle, 1.2 mm, 100/130 amp	10
C109-414	.11.843.021.414	S2014X	Nozzle, 1.4 mm, 130/160 amp	10
C109-114	.11.843.121.414	S2114X	Nozzle, 1.4 mm, 130 amp	10
C109-416	.11.843.021.416	S2016X	Nozzle, 1.6 mm, 160 amp	10
C109-116	.11.843.121.416	S2116X	Nozzle, 1.6 mm, 160 amp	10
7 C106-153	.11.835.221.153	Z101	Gas guiding cap, 0.4 mm	1
C109-154	.11.835.221.154	Z102	Gas guiding cap	1
8 K106-253	.11.834.321.153	Z111	Gas guide cap	1
9 C106-303	.11.835.421.303	Z111A	Spacer	1
10 C109-1010*	.11.843.021.310	S002X	SilverLine® electrode, XL	1
C109-1030*	.11.843.121.310	S012X	SilverLine electrode, XL	1
K109-152	.11.842.401.152		Cooling tube	1

Consumables – Stainless steel and aluminum

Centricut part number	Reference number	Alternate reference	Description	Pkg qty
1 C106-081	.11.835.201.081	Z501	Protection cap	1
3 C106-1581	.11.835.411.1581	Z4530	Swirl gas cap, 3.0 mm	1
C109-580	.11.835.411.1580	Z4535	Swirl gas cap, 3.5 mm	1
C106-1591	.11.835.411.1591	Z4540	Swirl gas cap, 4.0 mm	1
C109-590	.11.835.411.1590	Z4545	Swirl gas cap, 4.5 mm	1
4 C109-162	.11.842.401.162	S3008	Nozzle cap, 0.8 mm	1
C109-621	.11.842.401.1621	Z3018	Nozzle cap, 0.8 mm	1
6 C109-407	.11.843.021.407	S2007X	Nozzle, 0.7 mm, 35 amp	10
C109-408	.11.843.021.408	S2008X	Nozzle, 0.8 mm, 50/60 amp	10
C109-614	.11.843.111.614	S2514X	Nozzle, 1.4 mm, 120 amp	5
C109-616	.11.843.111.616	S2516X	Nozzle, 1.6 mm, 140 amp	5
C109-618	.11.843.111.618	S2518X	Nozzle, 1.8 mm, 160 amp	5
7 C106-153	.11.835.221.153	Z101	Gas guiding cap, 0.4 mm	1
8 K106-253	.11.834.321.153	Z111	Gas guide cap	1
11 C109-510	.11.842.411.510	S042	Electrode	1
C109-1510	.11.842.511.510	S052	Electrode	1
K109-152	.11.842.401.152		Cooling tube	1

Maintenance items

Centricut part number	Reference number	Alternate reference	Description	Pkg qty
027055	N/A		O-ring lube	1

* Centricut part features a unique Hypertherm design that differs from the OEM design.

OEM Kjellberg®

System FineFocus 800 Plus, HiFocus 280i/360i/440i

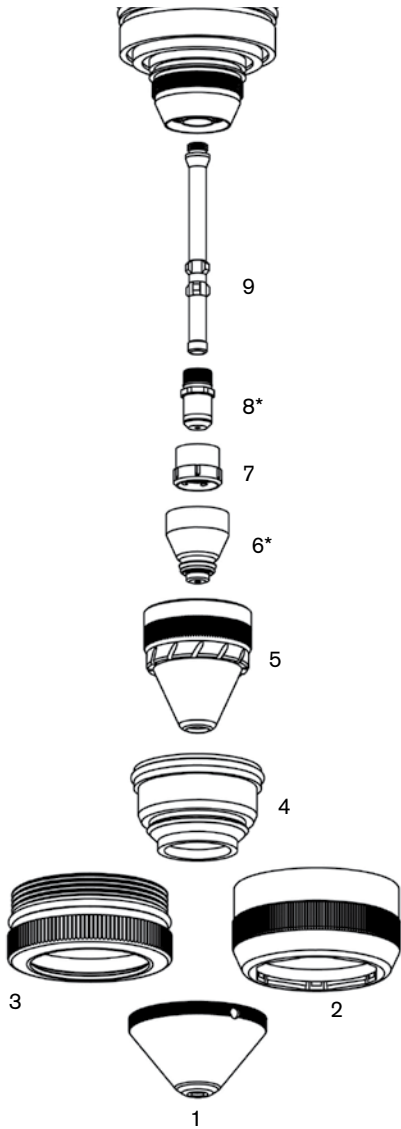

Consumables – Carbon steel

Centricut part number	Reference number	Alternate reference	Description	Pkg qty
1 C117-155	.11.833.101.155	V4335	Swirl gas cap, 3.5 mm	1
C117-157	.11.833.101.157	V4345	Swirl gas cap, 4.5 mm	1
2 C117-081	.11.841.721.081	T502	Protective cap, PerCut 370.2	1
3 C53-261	.11.833.101.261	V501	Protective cap, PB-S80	1
C117-261	.11.833.121.261	V502	Protective cap, PB-S80	1
4 C117-1271	.11.833.121.271	V522	Swirl gas nozzle, PerCut 370.2	1
C117-271	.11.836.901.271	T521	Swirl gas nozzle	1
C117-0271	.11.836.921.271	T522	Swirl gas nozzle, PB-S80	1
5 C117-163	.11.836.901.163	T3030	Nozzle cap	1
C117-164	.11.836.901.164	T3045	Nozzle cap	1
C117-165	.11.836.901.165	T3060	Nozzle cap	1
6 C117-415*	.11.846.921.415	T2115Y	CoolFlow™ nozzle, 1.5 mm, 120 amp	1
C117-420	.11.846.921.420	T2120Y	CoolFlow nozzle, 2.0 mm, 200 amp	1
C117-425	.11.846.921.425	T2125Y	CoolFlow nozzle, 2.5 mm, 250 amp	1
C117-427	.11.846.921.427	T2127Y	CoolFlow nozzle, 2.7 mm, 300 amp	1
C117-430	.11.846.921.430	T2130Y	CoolFlow nozzle, 3.0 mm, 360 amp	1
7 C117-153	.11.836.921.153	T101	Gas guide	1
C117-154	.11.836.921.154	T102	Gas guide	1
C117-542	.11.836.921.1542	T104	Gas guide	1
8 C117-1300*	.11.836.921.300	T012	SilverLine® electrode	1

Maintenance items

Centricut part number	Reference number	Alternate reference	Description	Pkg qty
027055	N/A		O-ring lube	1
9 C117-152	.11.844.901.152	T902Y	Water tube	1

* Centricut part features a unique Hypertherm design that differs from the OEM design.

**New
technology
consumables**

Consumables

Centricut part number	Reference number	Description	Pkg qty
1 C121-503	40020503	Protection cap	1
2 C121-366	40016366	Shield	1
3 C121-359	40016359	CoolFlow™ nozzle, 1.7R	10
C121-362	40016362	CoolFlow nozzle, 1.7L	10
C121-360	40016360	CoolFlow nozzle, 2.3R	10
C121-363	40016363	CoolFlow nozzle, 2.3L	10
C121-233	40017233	CoolFlow nozzle, 2.9R	10
C121-234	40017234	CoolFlow nozzle, 2.9L	10
4 C121-899	40001899	Swirl ring, R	1
C121-567	40004567	Swirl ring, L	1
5 C121-1058	40016358	SilverLine® electrode	5

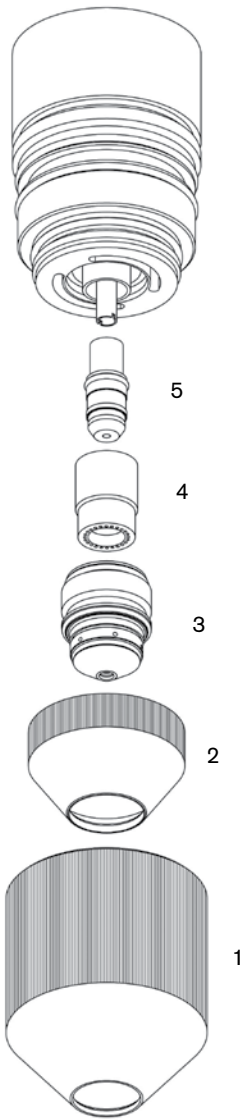

OEM Komatsu® System Razor 40 amp

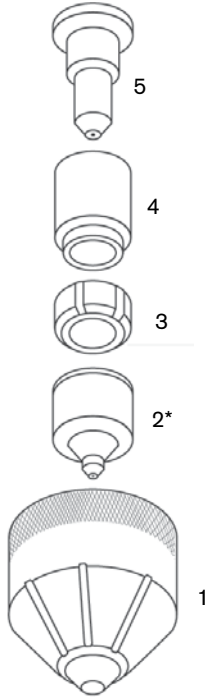

Consumables

Centricut part number	Reference number	Description	Pkg qty
C33-008T	N/A	Cap #1 with tab	1
1 C33-008	65-0432-001	Cap #1	1
2 C33-140	65-0432-003	Nozzle, O ₂ , 0.4 mm	5
C33-130	65-0432-002	Nozzle, O ₂ , 0.6 mm	5
C33-160	65-0432-013	Nozzle, O ₂ , 0.7 mm	5
C33-961*	N/A	Nozzle, O ₂ , 0.8 mm	5
3 C33-006	65-0432-006	Swirler, standard, CCW	1
C33-066	65-0432-066	Swirler, reverse, CW	1
4 C33-021	65-0432-021	Ceramic guide	1
5 C33-930	65-0432-005	Electrode with o-ring	5

Maintenance items

Centricut part number	Reference number	Description	Pkg qty
C33-007	65-0432-007	O-ring kit	3
K33-010	969-94-41010	Razor 40 torch body	1
K33-420	65-0432-020	Razor 40 torch body with 1.8 mm leads	1
027055	N/A	Lubricant .25 oz. (7 ml) tube	1

* Centricut part features a unique Hypertherm design that differs from the OEM design.

OEM Komatsu®

System Razor 90/120 amp

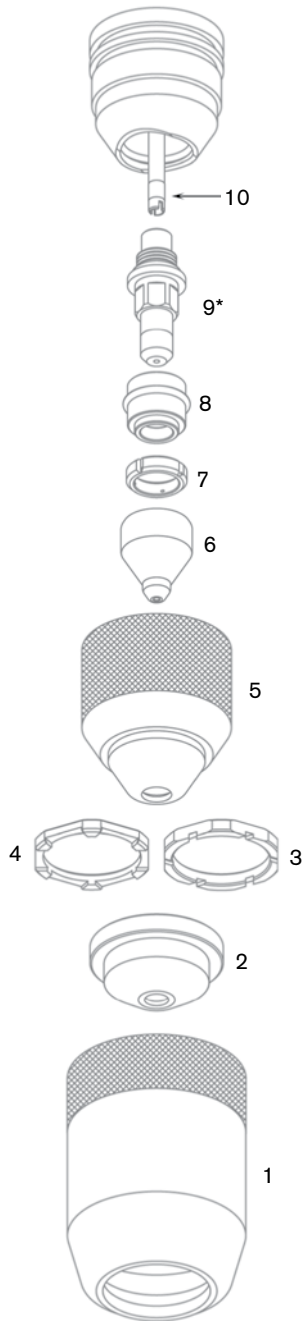

Consumables

Centricut part number	Reference number	Description	Pkg qty
2 C35-019	65-0434-019	Shield cap, 90 amp	1
C35-905	65-0442-005	Shield cap, 120 amp	1
C35-004	65-0438-004	Shield cap, quick silver	1
3 C35-250	65-0442-004	Spacer ring, 120 amp	1
4 C35-540	65-0434-022	Spacer ring, 90 amp	1
5 C35-015	65-0434-015	Cap #1	1
1 C35-016	65-0434-016	Cap #2	1
C35-020	65-0438-005	Cap #2, quick silver	1
6 C35-160	65-0434-017	Nozzle, O ₂ , 0.8 mm	5
C35-180	65-0434-007	Nozzle, O ₂ , 1.1 mm	5
C35-002	65-0442-002	Nozzle, O ₂ , 1.3 mm	5
C35-8002	65-0438-002	Nozzle, "S", 0.8 mm, quick silver	5
C35-8003	65-0438-003	Nozzle, "S", 1.1 mm, quick silver	5
7 C35-018	65-0434-018	Swirler, 90 amp, CCW	1
C35-003	65-0442-003	Swirler, 120 amp, CW	1
8 C35-350	65-0434-020	Ceramic guide with o-ring	1
9 C35-1020*	65-0442-001	SilverLine® electrode, 90-120 amp	1

Maintenance items

Centricut part number	Reference number	Description	Pkg qty
10 C35-110	65-0442-009	Cooling tube, 90/120 amp	1
K35-021	65-0434-021	O-ring kit	1
K35-006	65-0442-006	Razor 90/120 torch body without o-rings	1
K35-690	969-94-49690	Razor 90/120 torch body with 6' leads	1
027055	N/A	Lubricant .25 oz. (7 ml) tube	1

* Centricut part features a unique Hypertherm design that differs from the OEM design.

OEM Komatsu®

System Razor 300 amp

Consumables

Centricut part number	Reference number	Description	Pkg qty
1 C78-130	969-95-30130	Shield cap	1
2 C78-190	969-95-30190	Shield ring	1
3 C78-120	969-95-30210	Inner cap	1
4 C78-150	969-95-30150	Nozzle, 1.2 mm, 100 amp	1
C78-220	969-95-30220	Nozzle, 2.2 mm, 200 amp	1
C78-280	969-95-30140	Nozzle, 2.8 mm, 300 amp	1
5 C78-181	969-95-30181	Swirl ring	1
6 C78-171	969-95-30171	Guide, 300 amp	1
7 C78-1060*	969-95-30160	SilverLine® electrode, 300 amp	1

* Centricut part features a unique Hypertherm design that differs from the OEM design.

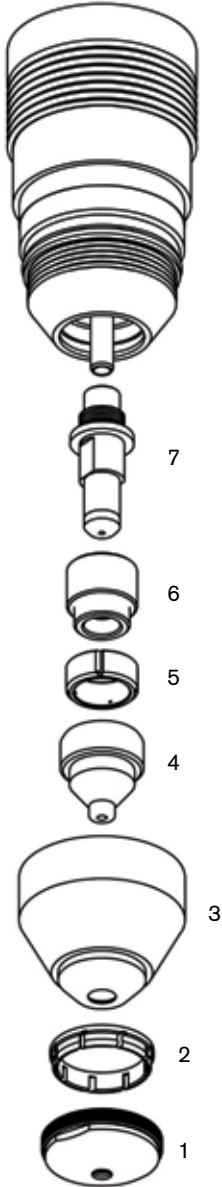

OEM Lincoln®

System PRO-CUT® 40 and 60

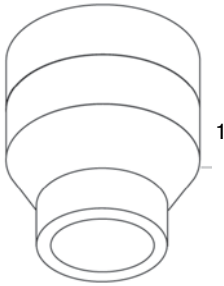
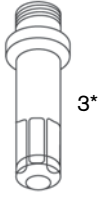

Consumables

Centricut part number	Reference number	Description	Pkg qty
1 L44-817	S18817	Shield cup, copper	1
L44-425	S19425	Drag cup, copper	1
2 C44-971*	S18497-1	Nozzle, Air, .035	5
C44-972*	S18497-2	Nozzle, Air, .042	5
C44-973*	S18497-3	Nozzle, Air, .052	5
3 C44-752*	S18752	Electrode, Air	5
L44-963	S19963	Swirl ring	1

Maintenance items

Centricut part number	Reference number	Description	Pkg qty
L44-616	M15616	Torch body	1
027055	N/A	Lubricant .25 oz. (7 ml) tube	1

* Centricut part features a unique Hypertherm design that differs from the OEM design.

PCH-20®

OEM Thermal Dynamics® System Dynapak 110®, PAK® 2XT™

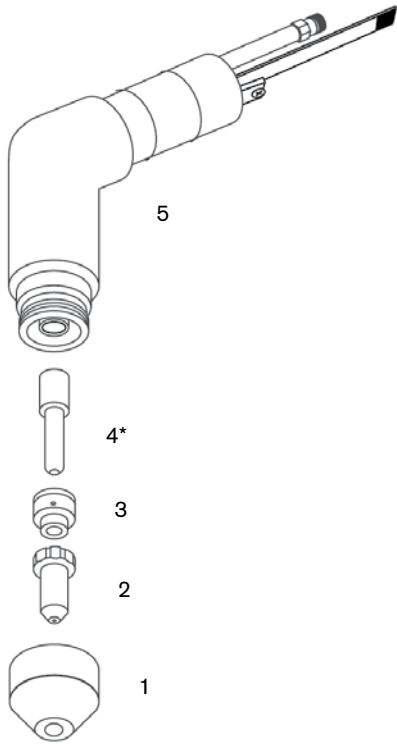

Consumables

Centricut part number	Reference number	Description	Pkg qty
1 C21-214	8-3214	Shield cup	5
2 C21-218	8-3218	Tip, .031	5
3 C28-233	8-3233	Gas distributor	1
4 C42-006*	9-6006	Electrode	5
C02-016	8-0531	O-ring	5

Maintenance items

Centricut part number	Reference number	Description	Pkg qty
5 T21-220	8-3220	PCH-20 torch body, 70°	1
027055	N/A	Lubricant .25 oz. (7 ml) tube	1

* Centricut part features a unique Hypertherm design that differs from the OEM design.

PCH/M-30®

OEM Thermal Dynamics® System PAK3®

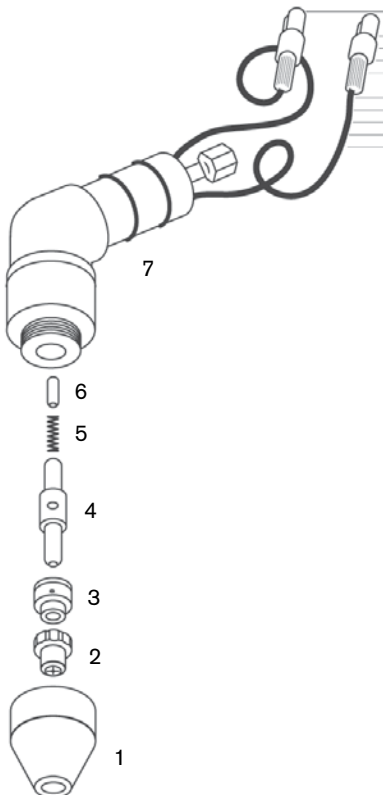

Consumables

Centricut part number	Reference number	Description	Pkg qty
1 T28-500	9-5500	Shield cup	10
2 C28-501	9-5501	Tip, .040	10
3 C28-233	8-3233	Gas distributor	1
4 C28-503	9-5503	Electrode	10
5 T28-505	9-5505	Spring	5
6 T28-504	9-5504	Continuity pin	5

Maintenance items

Centricut part number	Reference number	Description	Pkg qty
T28-509	9-5509	PCM-30 torch body, 180°	1
7 T28-512	9-5512	PCH-30 torch body, 70°	1
027055	N/A	Lubricant .25 oz. (7 ml) tube	1

Centricut is a registered trademark of Hypertherm, Inc. and may be registered in the United States and/or other countries. All other trademarks are the properties of their respective owners. Centricut is in no way affiliated with Thermal Dynamics.

OEM Thermal Dynamics® System PAK Master® 25, Econo PAK® 25, Drag Gun

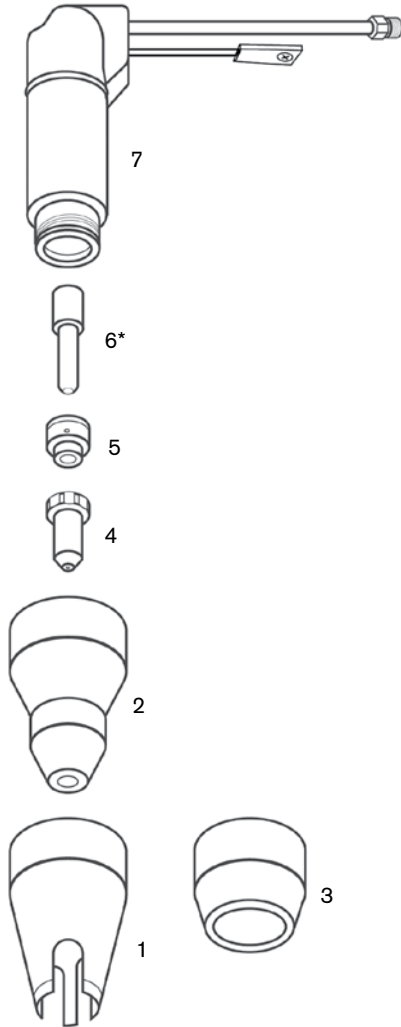

Consumables

Centricut part number	Reference number	Description	Pkg qty
1 C42-004	9-6004	Crown cup, copper	1
2 C42-003	9-6003	Shield cup	1
T42-503	9-6503	Shield cup, extended life, use with C42-003	1
4 C42-476	9-4476	Tip, drag cut, .026, 20 amp	5
T42-099	9-6099	Tip, drag cut, .026, 12 amp	10
5 C42-007	9-6007	Gas distributor	1
6 C42-006*	9-6006	Electrode	5

Maintenance items

Centricut part number	Reference number	Description	Pkg qty
7 T42-807	9-5807	PCH-25/35 torch body, 70°	1
T42-808	9-5808	PCH-25/35 torch body, 90°	1
T42-016	9-0016	PCH-10 torch body, 70°	1
027055	N/A	Lubricant .25 oz. (7 ml) tube	1

* Centricut part features a unique Hypertherm design that differs from the OEM design.

PCH/M-26/28/35/38®

OEM Thermal Dynamics® System STAK PAK® 35, PAK MASTER® 50, 38XL, ECONO PAK® 50

Consumables

Centricut part number	Reference number	Description	Pkg qty
1 C42-004	9-6004	Crown cup, copper, use with C42-003	1
2 C42-003	9-6003	Shield cup	1
3 T42-503	9-6503	Shield cup, extended life, use with C42-003	1
4 C42-001	9-6001	Tip, drag cut, .031, 35 amp	5
C42-501	9-6501	Tip, drag cut, extended life, .031, 35 amp	5
C42-476	9-4476	Tip, drag cut, .026, 20 amp	5
C42-000	9-6000	Tip, standoff, .031, 35 amp	10
C42-500	9-6500	Tip, standoff, extended life, .031, 35 amp	10
5 C42-007	9-6007	Gas distributor	1
C42-507	9-6507	Gas distributor, extended life	1
6 C42-006*	9-6006	Electrode	5
C42-506*	9-6506	Electrode, extended life	5

Maintenance items

Centricut part number	Reference number	Description	Pkg qty
7 T42-807	9-5807	PCH-25/35 torch body, 70°	1
T42-808	9-5808	PCH-25/35 torch body, 90°	1
T42-809	9-5809	PCM-35 torch body, 180°	1
027055	N/A	Lubricant .25 oz. (7 ml) tube	1

* Centricut part features a unique Hypertherm design that differs from the OEM design.

OEM Thermal Dynamics® System PAK®5

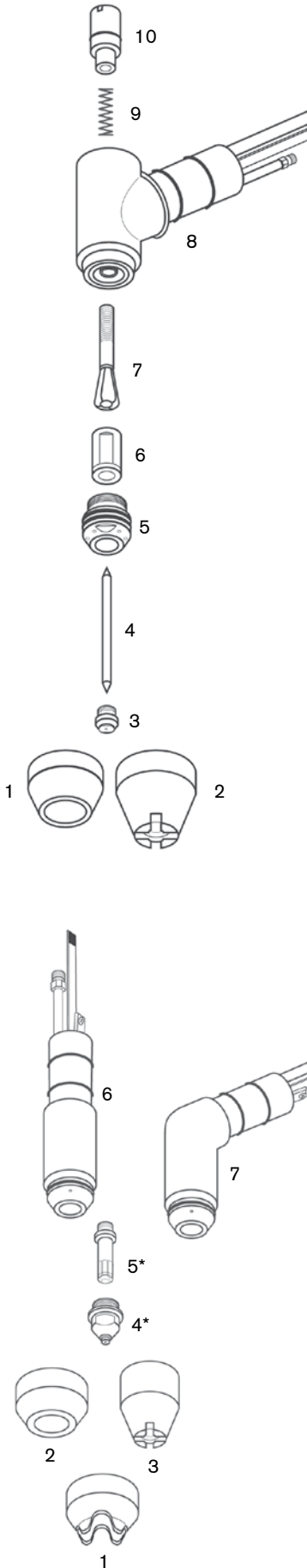

Consumables

Centricut part number	Reference number	Description	Pkg qty
1 T29-505	8-5505	Shield cup	5
2 T29-519	8-5519	Crown cup	5
3 T29-507	8-5507	Tip, .046	10
4 C29-508	8-5508	Electrode	5
5 T29-520	8-5520	Liner	1
6 T29-510	8-5510	Sleeve	1
7 T29-506	8-5506	Collet	5

Maintenance items

Centricut part number	Reference number	Description	Pkg qty
T29-504	8-5504	O-ring, torch body	5
8 T29-501	8-5501	PCH-50 torch body	1
9 T29-503	8-5503	Spring	5
10 T29-502	8-5502	Collet release button	1
027055	N/A	Lubricant .25 oz. (7 ml) tube	1

PCH/M-51®

OEM Thermal Dynamics® System PAK® 3XR™, 5XR™, 5Xt™, 6XR™, 625XR™, 750XR™, Dynapak 4Xi, 6Xi

Consumables

Centricut part number	Reference number	Description	Pkg qty
1 T06-779	9-5779	Crown cup, copper long, use with C06-781	1
C07-780	9-5780	Crown cup, copper short, use with C07-781	1
2 C06-630	9-5630	Shield cup, ceramic	5
3 C06-526	8-5526	Crown cup, ceramic	5
C06-781	8-2159	Shield cup, shatter proof	5
4 C06-631*	9-5631	Tip, chrome, .043, 55 amp	10
C06-031*	N/A	Tip, copper, .043, 55 amp	10
C06-718*	9-5718	Tip, chrome, .038, 35 amp	5
C06-321	8-3321	Tip, chrome, .047, 70 amp	5
C06-724	9-5724	Tip, chrome, gouging, .078	5
5 C06-633*	9-5633	Electrode, chrome	10
C06-033*	N/A	Electrode, copper	10

Maintenance items

Centricut part number	Reference number	Description	Pkg qty
6 C06-634	9-5634	PCM-51 torch body	1
7 C06-635	9-5635	PCH-51 torch body, 70°	1
C06-901	N/A	Bottoming tap, 7/16 in – 28, tip	1
C06-902	N/A	Bottoming tap, 1/4 in – 28, electrode	1
C06-525	8-5525	O-ring	5
C08-010	N/A	Ball casters	5
027055	N/A	Lubricant .25 oz. (7 ml) tube	1

* Centricut part features a unique Hypertherm design that differs from the OEM design.

OEM Thermal Dynamics[®] System PAK[®] 5XR[™], 6XR[™], 7XR[™], 8XR[™], 10XR[™], 625XR[™], 750XR[™], 1000XR[™], 1250XR[™]

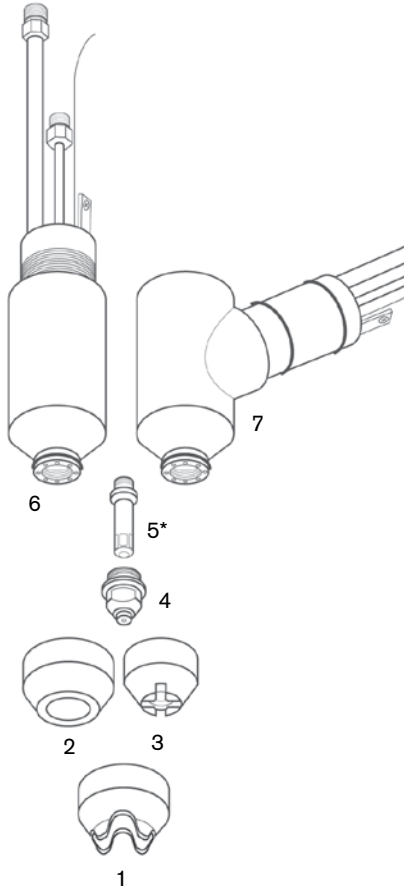

Consumables

Centricut part number	Reference number	Description	Pkg qty
1 T06-779	9-5779	Crown cup, copper long, use with C06-781	1
C07-780	9-5780	Crown cup, copper short, use with C07-781	1
3 C07-694	9-5694	Crown cup, ceramic	5
2 C07-717	N/A	Shield cup, short	10
C07-617	9-5617	Shield cup, long	5
C07-781	9-5781	Shield cup, shatter proof	5
4 C07-702	9-5702	Tip, .035, 35 amp	10
C07-618	9-5618	Tip, .043, 55 amp	10
C07-707	9-5707	Tip, .047, 70 amp	10
T07-782	9-5782	Tip, .052, 80 amp	5
C07-708	9-5708	Tip, .059, 105 amp	10
C07-908	N/A	Tip, .059, 105 amp, chrome	10
T07-710	9-5710	Tip, .093	10
5 C07-331*	8-3331	Electrode, Air, copper	10
C07-619	9-5619	Electrode, Air, chrome	10
T07-711	9-5711	Electrode, N ₂	5
C07-931	N/A	Electrode	10

Maintenance items

Centricut part number	Reference number	Description	Pkg qty
6 C07-643	9-5643	PCM-52 torch body	1
7 C07-642	9-5642	PCH-52 torch body, 70°	1
C06-525	8-5525	O-ring	5
C08-010	N/A	Ball casters	5
C07-901	N/A	Bottoming tap 1/2 – 20, tip	1
C07-902	N/A	Bottoming tap 7mm x 1, electrode	1
T07-007	8-4007	Wrench, tip	1
T07-620	9-5620	Wrench, electrode	1
027055	N/A	Lubricant .25 oz. (7 ml) tube	1

* Centricut part features a unique Hypertherm design that differs from the OEM design.

OEM Thermal Dynamics[®] System PAK MASTER[®] 100

Consumables

Centricut part number	Reference number	Description	Pkg qty
1 T06-779	9-5779	Crown cup, copper long, use with C06-781	1
C07-780	9-5780	Crown cup, copper short, use with C07-781	1
2 C07-717	N/A	Shield cup, short	10
C07-617	9-5617	Shield cup, long	5
C07-781	9-5781	Shield cup, shatter proof	5
3 C07-694	9-5694	Crown cup, ceramic	5
4 C07-702	9-5702	Tip, .035, 35 amp	10
C07-618	9-5618	Tip, .043, 55 amp	10
C07-707	9-5897	Tip, .047, 70 amp	10
T07-782	9-5782	Tip, .052, 80 amp	1
C07-708	9-5708	Tip, .059, 105 amp	10
C07-908	N/A	Tip, .059, chrome	10
T07-710	9-5710	Tip, .093	10
5 C07-331*	9-5898	Electrode, Air, copper	10

Maintenance items

Centricut part number	Reference number	Description	Pkg qty
6 T49-180	9-6180	PCM-53 torch body, 180°	1
7 T49-170	9-6170	PCH-53 torch body, 70°	1
T49-190	9-6190	PCH-53 torch body, 90°	1
C06-525	8-5525	O-ring	5
C08-010	N/A	Ball casters	5
C07-901	N/A	Bottoming tap 1/2 in. – 20, tip	1
C07-902	N/A	Bottoming tap 7mm x 1, electrode	1
T07-007	8-4007	Wrench, tip	1
T07-620	9-5620	Wrench, electrode	1
027055	N/A	Lubricant .25 oz. (7 ml) tube	1

* Centricut part features a unique Hypertherm design that differs from the OEM design.

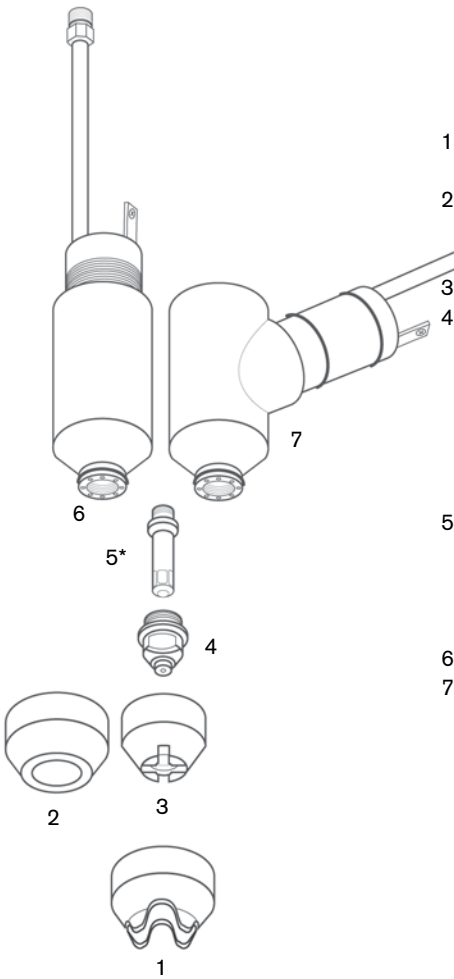

OEM Thermal Dynamics[®] System STAK PAK[®]

Consumables

Centricut part number	Reference number	Description	Pkg qty
1 T43-016	9-6016	Shield cup	1
2 T43-024	9-6024	Shield cup, long	1
C43-017	9-6017	Crown cup	1
3 C43-009	9-6009	Tip, Air, 70 amp	5
4 C43-022	9-6022	Gas distributor	1
5 C43-019*	9-6019	Electrode, Air	1

Maintenance items

Centricut part number	Reference number	Description	Pkg qty
6 T43-812	9-5812	PCM-70 torch body, 180°	1
7 T43-810	9-5810	PCH-70 torch body, 70°	1
027055	N/A	Lubricant .25 oz. (7 ml) tube	1

* Centricut part features a unique Hypertherm design that differs from the OEM design.

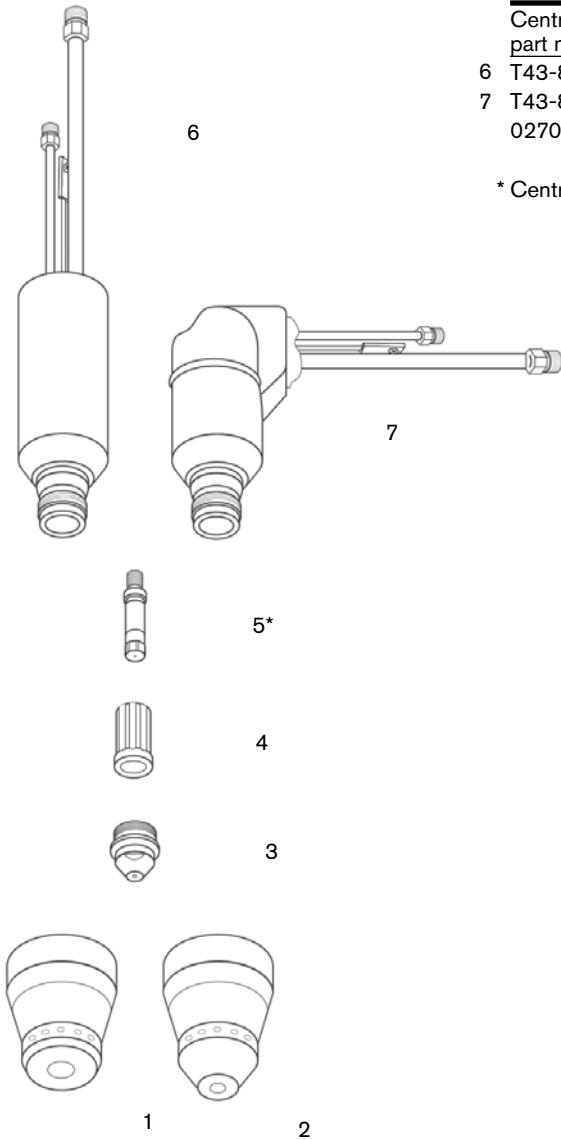

OEM Thermal Dynamics® System PAK® 22, 10, 5

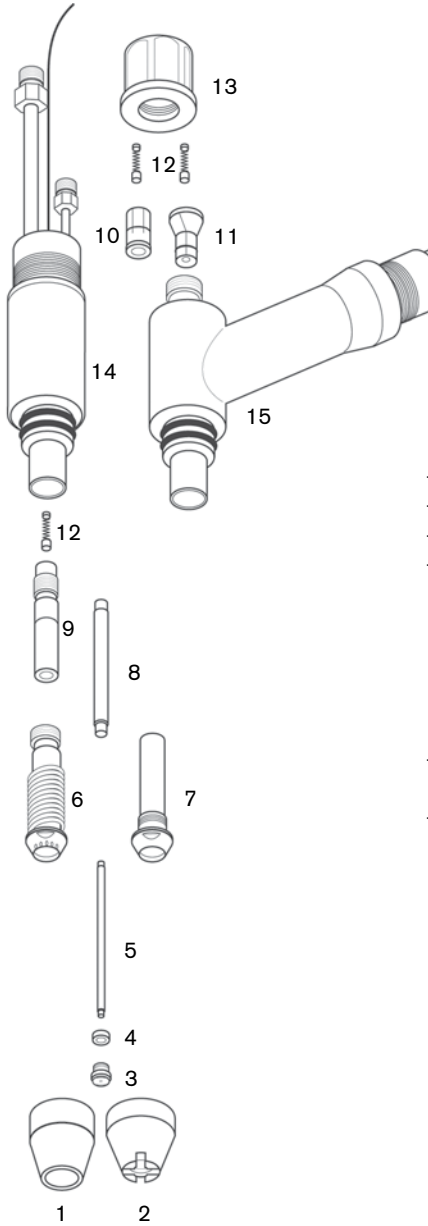

Consumables

Centricut part number	Reference number	Description	Pkg qty
1 C08-088	8-4088	Shield cup	5
2 T08-213	8-4213	Shield cup, crown	5
T08-045	8-4045	Shield cup, threaded 4A	1
3 C08-189	8-4189	Tip, .030	10
C08-211	8-4211	Tip, .046	10
C08-153	8-4153	Tip, .059, 100 amp	10
C08-170	8-4170	Tip, .070, ArH ₂ , 100 amp	10
4 C08-421	9-2421	Gas distributor	10
5 C08-073	8-4073	Electrode	5
6 C08-154	8-4154	Liner, 4B	1
7 T08-011	8-4011	Liner, 4A	1
8 C08-182	8-4182	Sleeve	1
9 T08-197	8-4197	Collet, 4BT	5
10 T08-156	8-4156	Collet, 4B	1
11 T08-049	8-4049	Collet, 4A	1
12 C08-050	8-4050	Spring assembly	5
13 T08-158	8-4158	Back cap	1
C08-069	8-4069	Gasket	5

Maintenance items

Centricut part number	Reference number	Description	Pkg qty
C08-010	N/A	Ball casters	5
14 T08-196	8-4196	PCM-4BT torch body	1
T08-161	8-4061	PCH-4B torch body, 90°	1
15 T08-160	8-4160	PCH-4B torch body, 70°	1
T08-901	9-1901	Insulating sleeve	1
027055	N/A	Lubricant .25 oz. (7 ml) tube	1

OEM Thermal Dynamics® System PAK® 44, 45

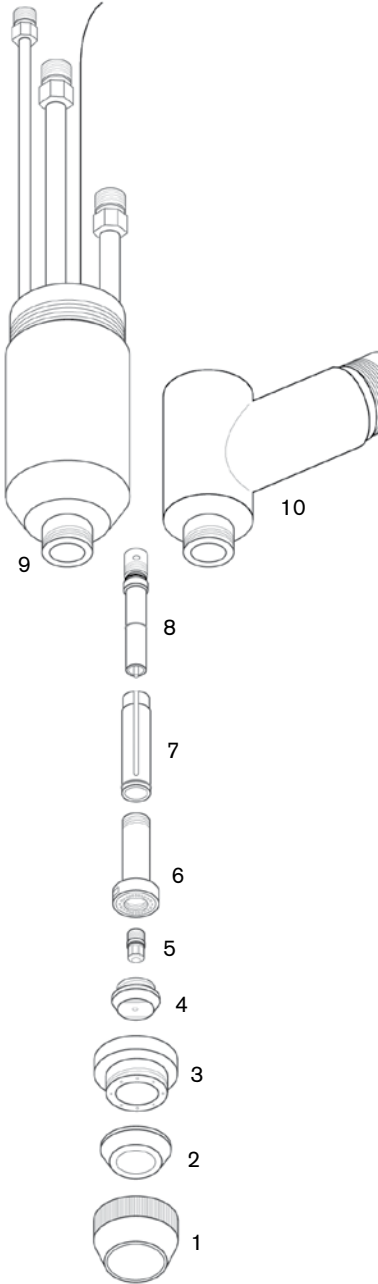

Consumables

Centricut part number	Reference number	Description	Pkg qty
1 C09-515	8-6515	End cap	1
2 C09-514	8-6514	End piece	5
3 C09-581	8-6581	Outer insulator	1
C09-512	8-6512	Gasket	5
4 C09-580	8-6580	Tip, .067, 100 amp	10
C09-648	8-6648	Tip, .076, 150 amp	10
C09-575	8-6575	Tip, .093, 200 amp	10
C09-582	8-6582	Tip, .113, 300 amp	10
C09-572	8-6572	Tip, .125, 400 amp	10
5 C09-578	8-6578	Electrode, general purpose	10
C09-586	8-6586	Electrode, low amp	10
6 C09-571	8-6571	Liner, includes o-rings C09-531 and C09-956	1
7 C09-569	8-6569	Gas distributor	1
T09-587	8-6587	Gas distributor, reverse swirl	1
T09-547	8-6547	Gas distributor	1
8 C09-615	8-6615	Electrode holder	1

Maintenance items

Centricut part number	Reference number	Description	Pkg qty
9 C09-577	8-6577	PCM-6B torch body, 180°	1
C09-584	8-6584	PCH-6B torch body, 90°	1
10 T09-583	8-6583	PCH-6B torch body, 70°	1
T09-614	8-6614	Heat shield, PCM-6B	1
027055	N/A	Lubricant .25 oz. (7 ml) tube	1

Note: Tips include o-rings C09-683 and C09-956

OEM Thermal Dynamics® System PAK® 10XR™

Consumables

Centricut part number	Reference number	Description	Pkg qty
1 C27-100	8-1100	Shield cup, hand	5
2 C27-345	9-4345	Shield cup, machine	5
3 C27-101	8-1101	Crown cup	5
4 C27-343	9-4343	Tip, .039, 35 amp	10
C27-342	9-4342	Tip, .047, 70 amp	10
C27-341	9-4341	Tip, .059, 105 amp	10
5 C27-340	9-4340	Electrode	10
6 C27-106	8-1106	Liner	1
7 C27-339	9-4339	Gas distributor	1
8 C27-108	8-1108	Electrode holder	1

Maintenance items

Centricut part number	Reference number	Description	Pkg qty
C27-111	N/A	Electrode wrench	
9 C27-112	8-1112	PCM-100 torch body	1
C27-113	8-1113	PCH-100 torch body, 70°	1
C27-556	8-0556	O-ring	5
C27-134	8-1134	O-ring, gas distributor	5
C27-152	8-1152	O-ring, electrode holder, large	5
C27-133	8-1133	O-ring, electrode holder, small	5
027055	N/A	Lubricant .25 oz. (7 ml) tube	1

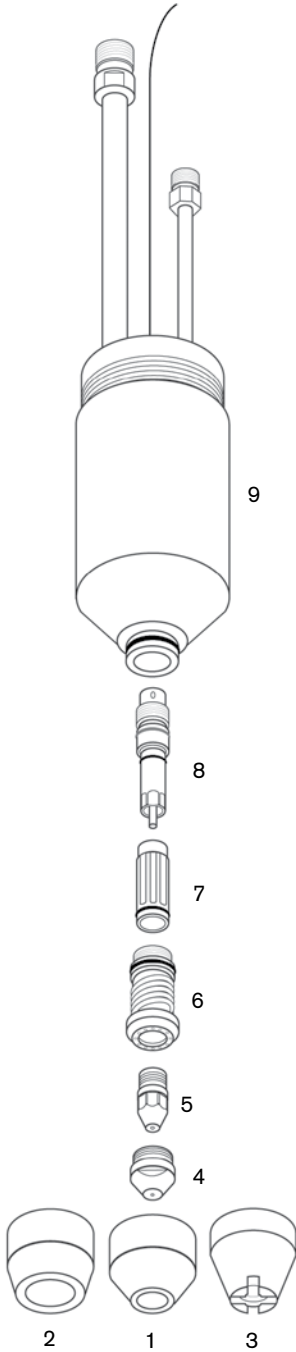

OEM Thermal Dynamics® System STAK PAK®

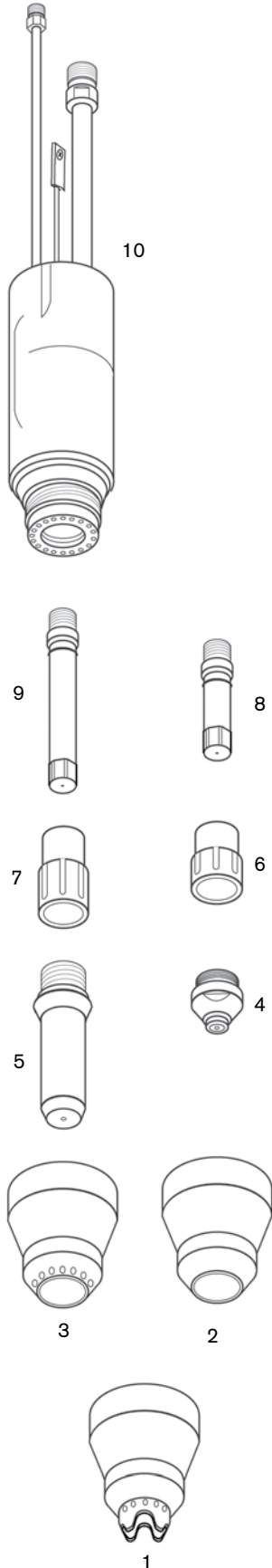

Consumables

Centricut part number	Reference number	Description	Pkg qty
1 T48-046	9-6046	Shield cup, crown	1
2 T48-047	9-6047	Shield cup, gouging	1
3 T48-045	9-6045	Shield cup	1
T48-054	9-6054	Shield cup, long	1
4 C48-025	9-6025	Tip, Air, 35 amp	5
C48-026	9-6026	Tip, Air, 70 amp	5
C48-027	9-6027	Tip, Air, 105 amp	5
C48-028	9-6028	Tip, Air, 140 amp	5
T48-034	9-6034	Tip, ArH ₂ , 70 amp	5
T48-035	9-6035	Tip, ArH ₂ , 105 amp	5
T48-036	9-6036	Tip, ArH ₂ , 140 amp	5
5 T48-037	9-6037	Tip, .110, gouging	1
T48-038	9-6038	Tip, .125, gouging	1
T48-039	9-6039	Tip, .156, gouging	1
T48-040	9-6040	Tip, .171, gouging	1
6 T48-051	9-6051	Gas distributor	1
7 T48-112	9-6112	Gas distributor, gouging	1
8 C48-048	9-6048	Electrode, Air	1
T48-050	9-6050	Electrode, ArH ₂	5
9 T48-110	9-6110	Electrode, Air, gouging	1

Maintenance items

Centricut part number	Reference number	Description	Pkg qty
T48-052	9-6052	Cooling tube	1
10 T48-815	9-5815	PCM-140 torch body, 180°	1
027055	N/A	Lubricant .25 oz. (7 ml) tube	1

OEM Thermal Dynamics[®] System PAK[®] 15XC, MERLIN[®]

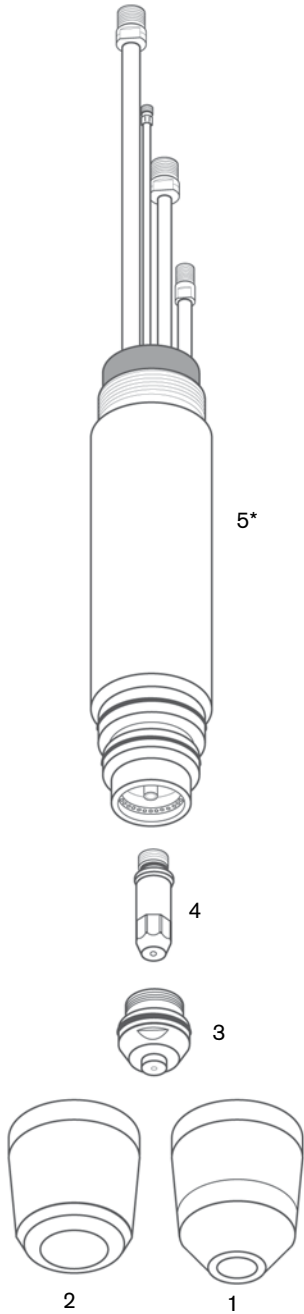

Consumables

Centricut part number	Reference number	Description	Pkg qty
1 C30-790	9-5790	Shield cup, copper	1
C30-750	9-5750	Shield cup	1
2 C30-758	9-5758	Shield cup, tip exposed	1
C30-801	9-5801	Shield cup, copper, tip exposed	1
3 C30-748	9-5748	Tip, Air, .043, 50 amp	5
C30-747	9-5747	Tip, Air, .055, 100 amp	5
C30-746	9-5746	Tip, Air, .070, 150 amp	5
C30-765	9-5765	Tip, N ₂ , .043, 50 amp	5
C30-766	9-5766	Tip, N ₂ , .052, 100 amp	5
C30-767	9-5767	Tip, N ₂ , .067, 150 amp	5
T30-753	9-5753	Tip, O ₂ , .043, 50 amp	5
T30-752	9-5752	Tip, O ₂ , .052, 100 amp	5
C30-751	9-5751	Tip, O ₂ , .070, 150 amp	5
4 C30-749	9-5749	Electrode, Air	5
C30-754	9-5754	Electrode, N ₂	5
C30-760	9-5760	Electrode, O ₂	5

Maintenance items

Centricut part number	Reference number	Description	Pkg qty
C30-M33	N/A	Liner, replacement	1
C30-M34	N/A	Gas distributor, replacement	1
C30-WRCH	N/A	Liner wrench	1
5 C30-945*	N/A	PCM-150 modular torch body, 180°	1
C30-057	N/A	O-ring torch kit – see below	1
027055	N/A	Lubricant .25 oz. (7 ml) tube	1

C30-057 O-ring torch kit includes

Centricut part number	Reference number	Description	Pkg qty
C30-035	N/A	O-ring (for gas distributor)	1
C30-037	N/A	O-ring (for liner)	1
C30-040	8-0540	O-ring (shield cup, large)	1
C30-557	8-0557	O-ring (shield cup, small)	5
C30-041	N/A	O-ring (for liner)	1

* Centricut part features a unique Hypertherm design that differs from the OEM design.

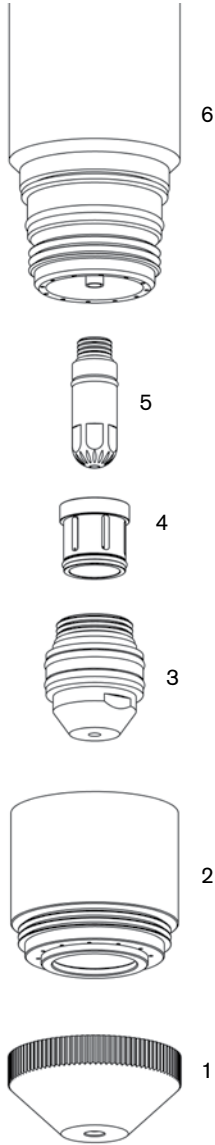

Consumables

Centricut part number	Reference number	Description	Pkg qty
1 C55-803	20-1003	Shield, 50 amp	1
C55-804	20-1004	Shield, 100 – 225 amp	1
C55-805	20-1005	Shield, 300 amp	1
C55-006	20-1006	Shield, 100 – 300 amp, underwater	1
T55-028	20-1028	Shield, 100 – 300 amp, underwater	1
2 C55-002	20-1002	Shield, cup body	1
T55-029	20-1029	Shield, cup body, underwater	1
T55-412	9-6412	Shield cup, Air, long	1
T88-744	9-6411	Shield cup, O ₂ , long	1
3 C55-030	20-1030	Tip, 50 amp	1
C55-031	20-1031	Tip, 100 amp	1
C55-032	20-1032	Tip, 150 amp	1
C55-033	20-1033	Tip, 225 amp	1
C55-034	20-1034	Tip, 300 amp	1
C55-424	9-6424	Tip, Air, 0.52, 70 amp	5
C55-425	9-6425	Tip, Air, 0.59, 105 amp	5
C55-432	9-6432	Tip, Air, 0.70, 150 amp	5
T55-419	9-6419	Tip, O ₂ , 0.52, 70 amp	5
T55-420	9-6420	Tip, O ₂ , 0.59, 105 amp	5
T55-433	9-6433	Tip, O ₂ , 0.70, 150 amp	5
T55-428	9-6428	Tip, ArH ₂ , 0.52, 70 amp	5
T55-429	9-6429	Tip, ArH ₂ , 0.59, 105 amp	5
T55-434	9-6434	Tip, ArH ₂ , 0.73, 150 amp	5
4 C55-008	20-0008	Gas distributor, 50 - 225 amp	1
T55-009	20-1009	Gas distributor, 300 amp	1
T55-416	9-6416	Gas distributor	1
5 C55-710	20-1016,	CopperLine® electrode, Air/O ₂ , 50 – 300 amp	1
	20-1010		1
	20-1021		1
C55-718	20-1015	CopperLine electrode, Air/O ₂ , 50 – 300 amp	1
	20-1018		1
T55-017	20-1017	Electrode, O ₂ , 225 amp	5
T55-023	20-1023	Electrode, N ₂ , 50 – 300 amp	5
T55-025	20-1025	Electrode, ArH ₂ , 100 – 300 amp	5
T55-1211	20-1211	Electrode, N ₂ , ArH ₂	5

Maintenance items

Centricut part number	Reference number	Description	Pkg qty
6 T55-410	9-6410	Maximizer 300 torch body	1
C55-004	N/A	O-ring	5
C55-050	N/A	O-ring	5
027055	N/A	Lubricant .25 oz. (7 ml) tube	1

OEM Thermal Dynamics[®] System TA500, 1000

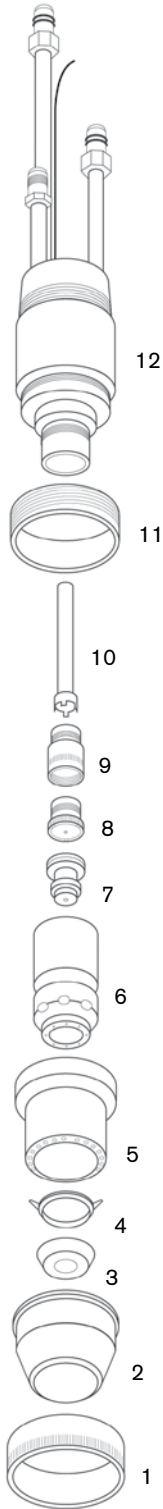

Consumables

Centricut part number	Reference number	Description	Pkg qty
1 T19-059	8-6059	Collar	1
T19-078	8-6078	Collar, underwater cutting	1
2 T19-056	8-6056	End cap	1
T19-077	8-6077	End cap, underwater cutting	1
3 C19-006	8-6006	End piece, water shield	10
C19-610	8-0610	End piece, piercing	5
T19-607	8-0607	End piece, gas shield	1
T19-029	8-6029	End piece, ArH ₂	1
T19-609	8-0609	End piece	1
6 T19-210	9-2210	Inner tip retainer	1
7 T19-041	8-6041	Tip, .081, 150 amp	1
C19-042	8-6042	Tip, .109, 250 amp	1
C19-043	8-6043	Tip, .125, 350 amp	1
C19-044	8-6044	Tip, .140, 500 amp	1
C19-045	8-6045	Tip, .172, 750 amp	1
C19-046	8-6046	Tip, .201, 1000 amp	1
T19-047	8-6047	Tip, .250, 500 amp	1
8 C19-662	9-1662	Electrode	5
T19-641	9-1641	Electrode, low amp	1
9 T19-642	9-1642	Electrode seat	1

Maintenance items

Centricut part number	Reference number	Description	Pkg qty
10 T19-640	9-1640	Coolant tube	1
11 T19-058	8-6058	Adaptor	1
12 T19-054	8-6054	M200 torch body	1
C19-563	8-0563	O-ring, end piece – end cap	5
4 T19-451	9-2451	Coolant baffle	1
5 T19-060	8-6060	Outer insulator	1
T19-720	9-3720	O-ring, end cap – outer insulator	5
T19-547	8-0547	O-ring, outer insulator – torch body	5
027055	N/A	Lubricant .25 oz. (7 ml) tube	1

OEM Whitney®

System OW250®

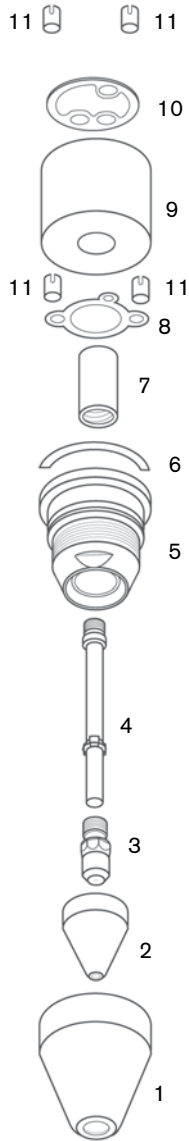

Consumables

Centricut part number	Reference number	Description	Pkg qty
1 C14-332	648-332	Nose piece	1
2 C14-330	648-330	Nozzle, Air, 063, 150 amp	5
C14-331-S	648-331	Nozzle, Air, .098	5
C14-731	N/A	Nozzle, Air, .110	5
3 C14-328	648-328	Electrode, low amp, Air, 150 amp	5
C14-327	648-327	Electrode, Air, with o-ring C14-010, 250 amp	5
C14-927	648-327	Electrode, Air, without o-ring, 250 amp	5

Maintenance items

Centricut part number	Reference number	Description	Pkg qty
4 C14-326	648-326	Cooling tube	1
5 C14-280	648-280	Nozzle holder	1
6 C14-282	648-282	Gasket spacers	2
7 C14-281	648-281	Gas guide ring	1
8 C14-286	648-286	Lower gasket	5
9 C14-287	648-287	Insulating spacer	1
10 C14-288	648-288	Middle gasket	5
11 C14-285	648-285	Hole guides	5
C14-010	N/A	O-ring	5
C14-283	648-283	O-ring	5
C14-284	648-284	O-ring	5
C14-793	649-793	O-ring seal	4
027055	N/A	Lubricant .25 oz. (7 ml) tube	1

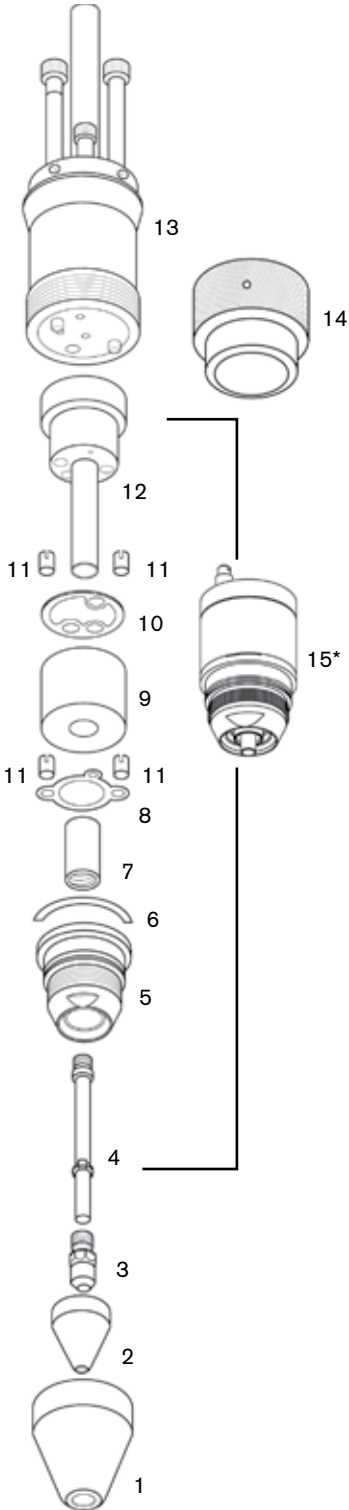

Consumables

Centricut part number	Reference number	Description	Pkg qty
1 C14-332	648-332	Nose piece	1
2 C14-330	648-330	Nozzle, Air, .063, 150 amp	5
C14-331-S	648-331	Nozzle, Air, .098	5
C14-731	N/A	Nozzle, Air, .110	5
3 C14-328	648-328	Electrode, low amp, Air, 150 amp	5
C14-327	648-327	Electrode, Air, with o-ring C14-010, 250 amp	5
C14-927	648-327	Electrode, Air, without o-ring, 250 amp	5

Maintenance items

Centricut part number	Reference number	Description	Pkg qty
4 C14-794	649-794	Cooling tube	1
5 C14-280	648-280	Nozzle holder	1
6 C14-282	648-282	Gasket spacers	2
7 C14-281	648-281	Gas guide ring	1
8 C14-286	648-286	Lower gasket	5
9 C14-959	649-959	Insulating spacer	1
10 C14-288	648-288	Middle gasket	5
11 C14-285	648-285	Hole guides	5
12 C14-960	649-960	Manifold	1
C14-793	649-793	O-ring seal	4
13 C14-964	649-964	Upper body	1
C14-962	649-962	High frequency socket	1
C14-963	649-963	High frequency pin	1
14 C14-961	649-961	Head cover assembly	1
C14-866	649-966	Torch tube cover	1
C14-765	649-765	IC300 one touch torch	1
15 C14-118*	N/A	Lower body assembly (includes items 4 – 12)	1
C14-010	N/A	O-ring	5
C14-283	648-283	O-ring	5
C14-284	648-284	O-ring	5
027055	N/A	Lubricant .25 oz. (7 ml) tube	1

* Centricut part features a unique Hypertherm design that differs from the OEM design.

OEM Whitney[®]

System TRUECUT[®]

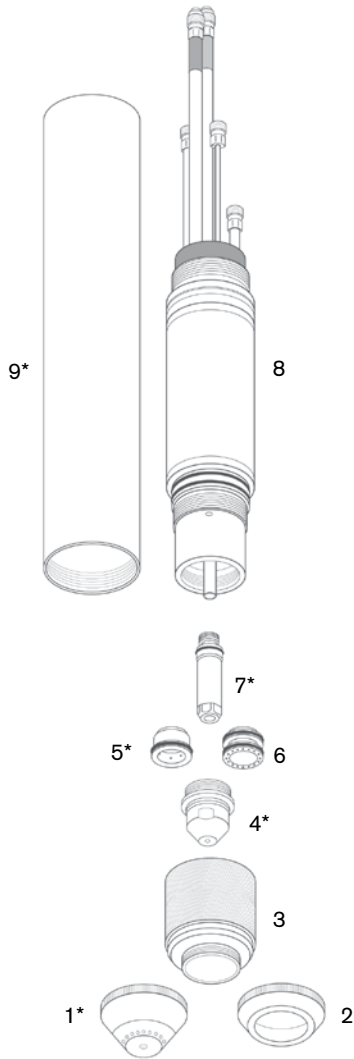

Consumables

Centricut part number	Reference number	Description	Pkg qty
1 020424	631-452	Shield, machine, Air, O ₂ , N ₂ , 200 amp	1
C32-924*	N/A	Shield, machine, Air, O ₂ , N ₂ , 200 amp	1
020448	631-453	Shield, Air, N ₂ , ArH ₂ , 100 amp	1
2 020668	631-454	Shield, machine, Air, 40 amp	1
3 020423	631-455	Retaining cap	1
4 C32-608	631-456	Nozzle, Air, .086, N ₂ , ArH ₂ , 200 amp	1
C32-611*	631-457	Nozzle, Air, .059, N ₂ , ArH ₂ , 100 amp	1
C32-689*	631-458	Nozzle, Air, .038, 40 amp	5
C32-605	631-459	Nozzle, O ₂ , .082, 200 amp	1
C32-690	632-459	Nozzle, O ₂ , .055, 100 amp	1
5 C32-907*	N/A	Swirl ring, Air, N ₂ , ArH ₂ , 100/200 amp	1
020613	631-462	Swirl ring, Air, 40 amp, and O ₂ , 100 amp	1
020679	632-455	Swirl ring, Air, 200 amp	1
6 020-678	632-456	Swirl ring, O ₂ , 200 amp	1
7 C32-664*	632-457	Electrode, O ₂ , 200 amp	1
C32-1021*	220021	SilverLine [®] electrode, O ₂ , 200 amp	1
C32-415	632-458	Electrode, N ₂ , ArH ₂	5
C32-547	633-706	Electrode, Air, O ₂ , 100 amp	5

Maintenance items

Centricut part number	Reference number	Description	Pkg qty
8 120584	632-599	Torch body, 180°	1
C32-027	632-597	O-ring	5
020963	632-870	Water tube	1
9 C32-431*	N/A	Double threaded mounting tube	1
027055	N/A	Lubricant .25 oz. (7 ml) tube	1

* Centricut part features a unique Hypertherm design that differs from the OEM design.

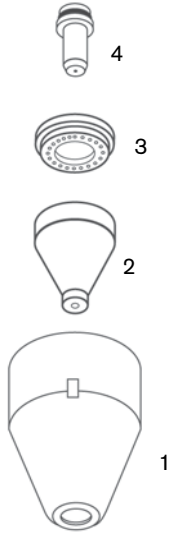

Consumables

	Centricut part number	Reference number	Description	Pkg qty
1	C13-458	88959458	Nose piece	1
2	C13-459	88959459	Nozzle, Air, .051	10
	C13-559	N/A	Nozzle, Air, .061	10
3	C13-461	88959461	Swirl ring	1
4	C13-462	88959462	Electrode, Air, with o-ring C13-463	10
	C13-460	88959460	O-ring	5
	C13-463	88959463	O-ring	5
	C13-475	88959475	O-ring	5



**Technology products for ESAB[®],
Kjellberg[®] and Kaliburn[®]**

Hypertherm[®]

Cut with confidence[®]

Hypertherm, Inc.
Hanover, NH 03755 USA
603-643-3441 Tel

Hypertherm (S) Pte Ltd.
Singapore 349567
65 6841 2489 Tel

**Hypertherm (Shanghai)
Trading Co., Ltd.**
PR China 200052
86-21 5258 3330 /1 Tel

Hypertherm Europe B.V.
4704 SE Roosendaal, Nederland
31 165 596907 Tel

HYPERTHERM BRASIL LTDA.
Guarulhos, SP - Brasil
55 11 2409 2636 Tel

www.hypertherm.com



Hypertherm and Centricut are registered trademarks of Hypertherm, Inc. and may be registered in the United States and/or other countries. All other trademarks are the properties of their respective owners.